



Region of Waterloo and Area Municipalities

Design Guidelines and Supplemental Specifications for Municipal Services

February 2023

2023 Modifications

Region of Waterloo and Area Municipal

Design Guidelines and Supplemental Specifications

For Municipal Services

The following table summarizes the major changes made in the 2023 DGSSMS. Minor changes due to typographical errors and/or slight rewording for clarity have not necessarily been included in the summary.

Section	Modification and Commentary
Part A	Overview
A.4	City of Cambridge and City of Guelph
Part B	Standards Design Guidelines
B.1.1	Approvals
B.1.2	Ontario Ministry of the Environment, Conservation and Parks Guidelines
B.1.10	Source Water Protection Requirements
B.1.10.1	Deleted and Combined with B.1.10
B.2.1.4.1	Transmission Watermains
B.2.5.3.2	Minimum Water Diameter
B.2.5.4	Depth of Cover
B.2.8.5	Minimum Clearance
B.2.8.6	Valve Depth
B.3.1.2.2	Industrial
B.3.1.9	Selection of Bedding and Class of Pipe – Flexible Pipe
B.3.1.10	Pipe Depth
B.3.2.7	Location
B.4.2.3	Manning's "n"

Section	Modification and Commentary
B.4.2.7	Seleccion of Bedding and Class of Pipe – Flexible Pipe
B.4.2.8	Pipe Depth
B.4.3.6	Location
B.4.4.1	Minimum Lead Size
B.4.4.2	Catchbasin Lead Depth
Part C	Material Specification
C.2.1.3.1	Manufacture AWWA C900
C.2.1.3.2	Fittings AWWA C900
C.2.1.3.3	Joint Restraints
C.2.1.4.2	Fittings - Non Metallic and Metallic
C.2.1.4.3	Joint Restraints
C.2.9.4	Main Stops
C.3.1	Pipe Materials
C.2.10	Additional manufacturer specified
Part D	Construction Specification
D.1.11.2	Surplus Excavated Material
D.2.2.3	Shutting Down or Charging Mains
D.2.3.1	General
D.2.3.2	Layout Plan
D.2.6.3.2	Valves
D.2.7.2	Live Tapping
D.2.7.3	Tapping for Connection 100mm and Large
D.2.8.2	Disinfection
Part E	Standard Drawings and Design Sheets
E2-02	Valve and Box Installation Detail (Up to 300mm Diameter)

Region of Waterloo and Area Municipalities
Design Guidelines and Supplemental Specifications
For Municipal Services
Part A
Overview

Overview

Table of Contents

A.1	General.....	1
A.1.1	Introduction	1
A.1.2	Area Municipalities.....	1
A.1.3	Purpose	2
A.1.4	Ontario Provincial Standards	2
A.1.5	Ontario Building Code.....	2
A.1.6	Municipal Services Considered.....	2
A.1.7	Implementation	3
A.1.8	Document Structure	3
A.1.9	Availability of Specifications.....	4
A.1.10	Updates / Notifications	4
A.2	Definitions.....	4
A.2.1.	Municipality:.....	4
A.2.2.	Region or Region of Waterloo:	4
A.2.3.	Chief Municipal Engineer:	4
A.2.4.	Developer:	4
A.2.5.	Engineer:.....	4
A.2.6.	Contract Administrator:	4
A.2.7.	Consultant:	5
A.2.8.	Initial Acceptance	5
A.2.9.	Warranty Period:	5
A.2.10.	Water Distribution Report:.....	5
A.2.11.	DGSSMS or SSMS:	5
A.2.12.	OPSS:.....	5
A.2.13.	OPSD:.....	5
A.3	Environment	5
A.4	Chief Municipal Engineer	6

A.1 General

A.1.1 Introduction

Many engineering consultants and construction contractors work within the municipalities that comprise the Region of Waterloo and surrounding areas. One of the common industry comments was that the design guidelines and contract specifications differ among the various area municipalities.

The Best Management Practices (BMP) Committee, which is comprised of representatives from the Region of Waterloo and area municipalities, has recognized that benefits will be realized for both the construction industry and municipalities if common design guidelines and contract specifications for municipal services are developed. A technical subcommittee of the Best Management Practices Committee was established to develop the Region of Waterloo and Area Municipal Design Guidelines and Supplemental Specifications for Municipal Services (DGSSMS). Key personnel from the area municipalities plus the Region of Waterloo were assigned to the project.

A.1.2 Area Municipalities

For the purposes of this document, the area municipalities include:

- City of Cambridge
- City of Guelph
- City of Kitchener
- Township of North Dumfries
- City of Waterloo
- Township of Wellesley
- Township of Wilmot
- Township of Woolwich

For the purposes of these specifications, the Region of Waterloo will also be considered an area municipality.

A.1.3 Application of Design, Material, and Construction Standards in the Region of Waterloo

During the construction on the Regional roads anywhere in the Region of Waterloo, the Region's standards, specifications and guidelines shall apply for the entire road right-of-way including the storm sewers. For the construction of the local municipality owned sanitary sewers and/or local distribution watermains within the Regional roads, the local municipality standards, specifications and guidelines shall apply. During the construction of Regional watermains and Regional storm sewers anywhere in the Region of Waterloo, the Region's standards, specifications and guidelines shall apply.

A.1.4 Purpose

The primary purpose and benefit of creating a common set of design guidelines and contract specifications is to facilitate the design and construction of municipal services by consultants and contractors that work in more than one municipality.

Although this document is often referred to as specifications, the design portion (Part B) should be considered as guidelines. This document provides the municipalities' design preferences under normal circumstances. The Engineer; however, should use their best judgement to find innovative solutions when abnormal design conditions are encountered. The Chief Municipal Engineer must approve any design modifications made by the Engineer outside of this document.

This document shall be used in conjunction with the local municipalities' respective subdivision standards and related documents.

A.1.5 Ontario Provincial Standards

The Region of Waterloo and Area Municipal Design Guidelines and Supplemental Specifications for Municipal Services are supplemental to the Ontario Provincial Standards (OPS) and thus take precedence over the related specifications (OPSS) and drawings (OPSD).

The standards to be followed during the design and construction of Joint Services projects will be determined by who owns the proposed infrastructure which is to be installed.

A.1.6 Ontario Building Code

The DGSSMS applies to municipally owned services. The installation of privately held services is governed by the Ontario Building Code and associated specifications (which may include DGSSMS).

A.1.7 Municipal Services Considered

The municipal services currently considered are:

- Watermains
- Sanitary Sewers
- Storm Sewers

For all other municipal services, the user must refer to that municipality's specifications.

The water and sanitary guidelines and specifications apply to distribution and collection only and do not apply to supply and/or treatment. Trunk servicing may use other or additional special specifications.

A.1.8 Implementation

The Region of Waterloo and Area Municipal Design Guidelines and Supplemental Specifications for Municipal Services is a standalone document (i.e. not bound into Contract Documents) that will be referenced in Engineering Agreements and Contract Documents. The Municipality; however, may issue municipal specific instructions or modifications to the specifications as part of a Special Conditions or Special Provisions Section within Construction Contracts. Similarly, modifications may also be made to address project specific requirements; however, the municipality under whose jurisdiction the work is undertaken must agree to any such modifications.

Check with individual municipalities for additional standards or requirements.

These specifications will be used on all municipal service additions and alterations including:

- Subdivisions
- Site Plans (Condominiums / Commercial / Industrial Lands)
- Reconstruction
- Improvements and augmentations
- Operations and maintenance

In the case where the DGSSMS and the individual municipality's standards (e.g. Development Manual) differ, the individual municipality's standard(s) will supersede the DGSSMS.

A.1.9 Document Structure

The document is structured in the following manner:

- Part A: Overview
- Part B: Design Guidelines
- Part C: Materials Specifications
- Part D: Construction Specifications
- Part E: Standard Drawings and Forms
 - Watermain Commissioning Plan Template
 - Hydrostatic Pressure Test Template
 - Tracer Wire Conductivity Test Template
 - Water Services Procedure: Standard Practices for Construction Work Near a Well Field
- Part F: Special Product Approval With Conditions

A.1.10 Availability of Specifications

The current specifications are available free of charge via the Region of Waterloo's website.

A.1.11 Updates / Notifications

On a regular basis the Technical Sub-Committee of the Best Management Practices Committee will meet to review the specifications in light of comments received and the introduction of new materials and procedures. For manufactures and suppliers who wish to have their products reviewed please download the product approval form from the Region of Waterloo web site.

Comments are encouraged and may be forwarded to:

BMP Technical Sub-Committee

c/o Design and Construction Division

Transportation and Environmental Services Department

Regional Municipality of Waterloo

150 Frederick St, 6th Floor

Kitchener, Ontario N2G 4J3

Email: JBorovicka@regionofwaterloo.ca

A.2 Definitions

- A.2.1. Municipality:** Refers to the municipality having jurisdiction over the works and includes, for the purpose of this document, the Regional Municipality of Waterloo.
- A.2.2. Region or Region of Waterloo:** Regional Municipality of Waterloo will be referred to as a municipality for the purposes of this document
- A.2.3. Chief Municipal Engineer:** That individual(s) within the Municipality having responsibility for the specification of design, construction and materials. This individual will be specified by the Municipality. The words "Chief Municipal Engineer" is considered to be appended with the words "or their authorized designate". All approvals, design alterations or other instructions must be issued in writing by the Chief Municipal Engineer or their authorized designate before being considered valid.
- A.2.4. Developer:** The owner of land upon which municipal services will be located and ultimately owned by the Municipality.
- A.2.5. Engineer:** The licensed individual or firm responsible for the design of the works or their designate. May also be referred to as the Design Engineer.
- A.2.6. Contract Administrator:** The individual or firm responsible for overseeing the construction of the works and representing the municipality's interests.

- A.2.7. Consultant:** Consulting Engineering firm retained by, or on behalf of the Municipality. This reference may also include municipal staff depending on the context.
- A.2.8. Initial Acceptance:** This can be either the Initiation of the Maintenance Guarantee Period for subdivision servicing or the Substantial Completion of the Contract for other work. This is typically when the Municipality assumes ownership of the works subject to the Warranty Period.
- A.2.9. Warranty Period:** During this period of time, the Contractor is responsible for all costs related to repairing any defects in materials or workmanship. The Municipality will specify the length of the warranty period.
- A.2.10. Water Distribution Report:** This report is prepared by the designer to document the analysis completed to determine the layout and sizing of a watermain or water distribution system
- A.2.11. DGSSMS or SSMS:** The Region of Waterloo and Area Municipal Design Guidelines and Supplemental Specifications for Municipal Services
- A.2.12. OPSS:** Ontario Provincial Standard Specifications
- A.2.13. OPSD:** Ontario Provincial Standard Drawings
- MECP:** Ministry of Environment Conservation and Parks
- AWWA:** American Water Works Association
- CSA:** Canadian Standards Association
- OHSA:** The Occupational Health and Safety Act
- OTM:** Ontario Traffic Manual
- CCTV:** Closed-Circuit Television
- OBC:** Ontario Building Code

A.3 Environment

It is the aim of all the area municipalities and the Regional Municipality of Waterloo to be environmentally responsible during all phases of the design, construction and operation of all municipal services.

The users of these guidelines and specifications must be familiar with the environmental protection standards laid out within this document and by the various area municipalities, federal and provincial legislation.

A.4 Chief Municipal Engineer

For the purpose of this document, the Chief Municipal Engineer for each Municipality shall be defined as per Table A1. The Chief Municipal Engineer may designate municipal staff or others to act on their behalf.

Table A1: Position of Chief Municipal Engineer	
Municipality	Chief Municipal Engineer
City of Cambridge	Director of Engineering
City of Guelph	General Manager/City Engineer
City of Kitchener	Manager, Quality Management and Water Programs Director of Engineering Services
City of Waterloo	Director Engineering Services Director of City Utilities
Township of North Dumfries	Township Engineer see Region of Waterloo for water and sanitary
Township of Wellesley	Director of Public Works and Environment for storm see Region of Waterloo for water and sanitary
Township of Wilmot	Director of Public Works
Township of Woolwich	Director of Infrastructure Services
Region of Waterloo	Commissioner of Engineering and Environmental Services

Region of Waterloo and Area Municipalities
Design Guidelines and Supplemental Specifications
For Municipal Services
Part B
Design Guidelines

Design Guidelines

Table of Contents

B.1	General	1
B.1.1	Approvals	1
B.1.2	Ontario Ministry of the Environment, Conservation and Parks Guidelines	1
B.1.3	Definitions	1
B.1.4	Alterations to Design Guidelines	1
B.1.5	Impact of Works on Existing System	1
B.1.6	Easements	1
B.1.7	Constructability	2
B.1.8	Record Drawings	2
B.1.9	Construction Near a Regional Well Field	4
B.1.10	Sourcewater Protection Requirements	4
B.1.10.1	Environmental Compliance Approval for Transfer of Review for Sewage Works.....	4
B.2	Watermains	5
B.2.1	Watermain Classification – Region of Waterloo	5
B.2.1.1	General	5
B.2.1.2	Regional Watermains	5
B.2.1.3	Local Watermains	6
B.2.1.4	Connection to Regional Watermains.....	6
B.2.2	Water Demand	7
B.2.2.1	Definitions	7
B.2.2.2	Domestic	7
B.2.2.3	Fire Flow	7
B.2.2.4	Design Period	7
B.2.2.5	Peaking Factors	7
B.2.3	Hydraulic Analysis	8
B.2.3.1	Friction Factors	8
B.2.3.2	Nominal vs. Actual Diameter	8
B.2.3.3	Capacity	8
B.2.3.4	Maximum Velocity	8

B.2.3.5	Transient Pressure	8
B.2.4	Pressure	9
B.2.4.1	Pressure Zone Delineation.....	9
B.2.4.2	Boundary Conditions	9
B.2.4.3	Preferred Pressure Range	9
B.2.4.4	Minimum Pressure	9
B.2.4.5	Maximum Pressure	9
B.2.4.6	In-Line Booster Pumps	9
B.2.4.7	Individual Pressure Reducing Devices	10
B.2.4.8	Design Pressure Location	10
B.2.5	Pipework.....	10
B.2.5.1	Material	10
B.2.5.2	Location	10
B.2.5.3	Diameter	11
B.2.5.3.1	General	11
B.2.5.3.2	Minimum	11
B.2.5.3.3	Maximum.....	11
B.2.5.4	Depth of Cover.....	11
B.2.5.5	Vertical Connection to Existing System.....	11
B.2.5.6	High Points	12
B.2.5.7	Minimum Slope	12
B.2.5.8	Dead-end Mains.....	12
B.2.5.9	Cul-de-sac Servicing	12
B.2.5.10	Minimum Clearance to Sewers.....	12
B.2.5.11	Thrust Restraint	12
B.2.5.12	Soil Settlement Areas	13
B.2.6	Water Quality.....	13
B.2.6.1	Minimum Chlorine Residual	13
B.2.6.2	Design Considerations	13
B.2.7	Hydrants	13
B.2.7.1	Maximum Spacing.....	13

B.2.7.2	Lead Size	14
B.2.7.3	Location	14
B.2.7.4	Bends.....	14
B.2.7.5	Minimum Clearance	14
B.2.8	Isolation Valving	15
B.2.8.1	Size.....	15
B.2.8.2	Location	15
B.2.8.3	Maximum Spacing.....	15
B.2.8.4	Direct Bury.....	15
B.2.8.5	Minimum Clearance	16
B.2.8.6	Valve Depth.....	16
B.2.9	Combination Air & Vacuum Release Valves.....	16
B.2.9.1	Utilisation.....	16
B.2.9.2	Watermain Profile.....	16
B.2.9.3	Sizing	16
B.2.10	Drain Chambers	17
B.2.10.1	Utilisation.....	17
B.2.10.2	Location	17
B.2.11	Flushing and Swabbing Ports	17
B.2.11.1	Utilisation.....	17
B.2.12	Services	17
B.2.12.1	Sizing	17
B.2.12.2	Location	17
B.2.12.3	Number of Services per Property	17
B.2.12.4	Restraints	18
B.2.12.5	Bends.....	18
B.2.12.6	Valving	18
B.2.12.7	Metering	18
B.2.12.8	Allowance for Future Servicing.....	18
B.2.12.9	Electrical Grounding	18
B.2.13	Geotechnical Report.....	19
B.2.13.1	Requirements	19

B.2.14	Corrosion Protection	19
B.2.14.1	Non-Metallic Watermain	19
B.2.14.2	Metallic Watermain.....	19
B.2.15	Watermain Identification	20
B.3	Sanitary	20
B.3.1	Pipework	20
B.3.1.1	Design flow.....	20
B.3.1.2	Flow Calculations	20
B.3.1.3	Design Flow Calculations.....	21
B.3.1.4	Minimum Pipe Size	21
B.3.1.5	Manning’s “n”	21
B.3.1.6	Pipe Slope	22
B.3.1.7	Flow Velocities.....	22
B.3.1.8	Selection of Bedding and Class of Pipe – Rigid Pipe	22
B.3.1.9	Selection of Bedding and Class of Pipe – Flexible Pipe.....	22
B.3.1.10	Pipe Depth.....	22
B.3.2	Maintenance Holes	23
B.3.2.1	Structure	23
B.3.2.2	Spacing	23
B.3.2.3	Size.....	23
B.3.2.4	Drop Inlet Structures	23
B.3.2.5	Safety Grates.....	23
B.3.2.6	Minimum Invert Drop	23
B.3.2.7	Location	23
B.3.2.8	Watertight Lids.....	24
B.3.2.9	Flow Direction Changes.....	24
B.3.3	Services	24
B.3.3.1	Minimum Diameter	24
B.3.3.2	Location	24
B.3.3.3	Slope	24
B.3.3.4	Depth	24

B.3.3.5	Connections to Maintenance Holes	24
B.3.4	Curvilinear Sewers	25
B.3.5	Geotechnical Report.....	25
B.4	Storm.....	25
B.4.1	General	25
B.4.2	Pipework.....	25
B.4.2.1	Design Flow Calculations.....	25
B.4.2.2	Minimum Pipe Size	29
B.4.2.3	Manning’s “n”	29
B.4.2.4	Pipe Slope	29
B.4.2.5	Flow Velocities	29
B.4.2.6	Selection of Bedding and Class of Pipe – Rigid Pipe	29
B.4.2.7	Selection of Bedding and Class of Pipe – Flexible Pipe.....	29
B.4.2.8	Pipe Depth.....	30
B.4.2.9	Curvilinear Sewers	30
B.4.2.10	Elliptical Sewers.....	30
B.4.2.11	Blind Connections	30
B.4.2.12	Safety / Rodent Grates	30
B.4.2.13	Head Walls	30
B.4.3	Maintenance Holes	31
B.4.3.1	Structure	30
B.4.3.2	Spacing.....	30
B.4.3.3	Size.....	30
B.4.3.4	Tee Maintenance Holes	30
B.4.3.5	Drop Inlet Structures	30
B.4.3.6	Location	30
B.4.3.7	Safety Grates.....	30
B.4.3.8	Minimum Invert Drop.....	30
B.4.3.9	Flow Direction Changes.....	31
B.4.4	Catchbasins	32
B.4.4.1	Minimum Lead Size.....	32
B.4.4.2	Catchbasin Lead Depth	32

B.4.4.3	Spacing	32
B.4.4.4	Intersection Location	33
B.4.4.5	Flow Direction Changes.....	33
B.4.4.6	Double Catchbasin.....	33
B.4.4.7	Side Inlet Catchbasin.....	33
B.4.4.8	Double Catchbasin with Curb Inlet Overflow.....	33
B.4.4.9	Sub-drains	33
B.4.4.10	Slotted Drain Pipe	34
B.4.4.11	Rear Yard Drainage	34
B.4.5	Services	34
B.4.5.1	Minimum Diameter.....	33
B.4.5.2	Location	33
B.4.5.3	Slope.....	33
B.4.5.4	Flow Direction Changes.....	33
B.4.5.5	Depth	33
B.4.6	Geotechnical Report	35
B.4.7	Open Ditch and Culvert Design	35

B.1 General

Designer to confirm ownership of infrastructure and applicable standards **see A.1.3**

B.1.1 Approvals

All watermain and sewer projects are subject to the Ministry of Environment, Conservation and Parks (MECP) and municipal approval process.

To remain in compliance with each area municipality's Municipal Drinking Water Licence and Consolidated Linear Infrastructure Environmental Compliance Approval (CLI ECA) for both sanitary and stormwater systems, municipal system alterations (additions, modifications, replacements or extensions) that meet the preauthorized criteria can be submitted directly to the respective municipality for approval. The Engineer is referred to the MECP latest issue of Watermain Design Criteria for Future Alterations Authorized under a Drinking Water Works Permit and Design Criteria for Sanitary Sewers, Storm Sewers and Forcemains for Alterations Authorized under Environmental Compliance Approval (MECP Design Criteria) to determine if the system alteration meets the preauthorized criteria. The Engineer is required to complete the applicable Record of Future Alteration Authorized forms for each system and submit to the respective municipality for approval prior to construction. The engineer is referred to the MECP Design Criteria documents for the submission documentation and testing plan requirements.

For greater clarity, where the conditions of the CLI ECA and the MECP Design Criteria are not met, the area municipality does not have the authority to approve the alteration and therefore, the project will require direct application to the MECP.

B.1.2 Ontario Ministry of the Environment, Conservation and Parks Guidelines

B.1.3 The Engineer is referred to the Ontario Ministry of the Environment, Conservation and Parks (MECP) latest issue of Guidelines for the Design of Sewage Works, Drinking Water Systems and Stormwater Management Planning and Design (both referred to herein as MECP Design Guidelines) for the minimum standards to be used. The DGSSMS are supplemental to the MECP Design Guidelines. Definitions

B.1.4 Alterations to Design Guidelines

The Chief Municipal Engineer reserves the right to modify these design guidelines in writing or to provide written direction to the Engineer as it may relate to project specific requirements.

The Engineer may submit a written request to the Chief Municipal Engineer to waive or modify a portion of the Design Guidelines on a project by project basis. The submission must be accompanied by documentation to substantiate the modifications.

B.1.5 Impact of Works on Existing System

The Engineer is responsible to determine and to mitigate the impact of the new works on the existing system and its users both inside and outside of the project limits.

B.1.6 Easements

The minimum easement width shall be the greater of:

- a) 2 x depth where the depth is from the proposed final grade to the invert rounded up to the nearest half metre
- b) 5.0 m in **Guelph, Kitchener, Cambridge, Region of Waterloo, and Waterloo**
- c) 6.0 m (4.0 m if concrete encased) in the **Township of Wilmot and Township of Woolwich**

The Engineer shall also consider the soil conditions and constructability and future maintenance when selecting the easement width. In addition, if more than one utility is installed in the easement, the easement width should be increased by the separation distance of the utilities.

B.1.7 Constructability

The Engineer shall consider the constructability and phasing of the proposed works that the works can be constructed in a cost effective manner and that the impact to the adjacent property owners and residents is minimized.

The Engineer shall contact the local operating authorities of the water distribution and sewer collection system to determine if there are possible adverse ramifications within the existing systems, within or outside of the construction limits, due to the construction of the works. The Engineer shall take reasonable measures to minimize any adverse effects outside of the construction limits.

The Engineer shall contact the local operating authorities of all utilities to coordinate the installation of the works.

B.1.8 Record Drawings

In addition to standard drawing information, include the following information on the record drawings for the project.

General:

- “Record Drawing” to be shown in the revision block
- Remove all construction notes
- Show registered plan number on all drawings (if applicable)

Watermains and Forcemains:

- Plan and profiles for all main lines
- Top of watermain elevation shots at a minimum 50m spacing, including every fitting
- Main size and pipe material (including DR rating and IPS/DIPS, product name where applicable)

- Service size and pipe material (including type and rating, product name where applicable) – on private and public side
- Swing ties to appurtenances, services and anode locations
- Thrust restraint (type, locations and/or extents)
- Special features (casings, insulation, trench cut-off walls, special gasket material, etc.)
- Final shop drawings for concrete pressure pipe (CPP) scanned and added to detail sheets
- Heat fusion reports
- Include locations of insulated / heat traced pipe
- Add material list as per Section D

Sewers:

- Plan and profiles
- Surveyed invert elevations
- Re-calculated pipe grades and design sheets
- Measured lengths
- Pipe strength
- MH sizes
- Special features (casings, concrete bedding, trench cut-off walls, etc.)
- Service size and material (private/public side), top of pipe at property line.
- Pipe Material and product name as per Section D
- Subdrains size and material and location
- Swing ties to locations where proposed sewer connects to existing sewer main
- Swing ties to existing sanitary and storm sewer services (building corners)
- Show all abandoned and grout filled pipes/manholes including method of abandonment

All main and service feature locations and inverts/top of pipe levels are to be positioned in the digital drawing files to within 100 mm (at drawing scale) of the actual recorded location on the plan and actual recorded elevation on the profile.

Record drawings shall be provided in both hardcopy and digital formats (latest version of AutoCAD) to the Chief Municipal Engineer within three months following completion of the project.

Check with individual municipalities for additional record drawing requirements (e.g. Kitchener's requirements are included in the Development Manual, electrical as per OPS).

CCTV videos to be included for storm sewer and sanitary sewers including laterals, all in accordance with the municipality. The Township of Wilmot requires CCTV on laterals for capital and development projects.

B.1.9 Construction near a Regional Well Field

Construction work planned within 200 m of any Regional Supply Well must follow standard practices and procedures. Refer to Part E for "Water Services Procedure: Standard Practices for Construction Work Near a Well Field".

B.1.10 Source Water Protection Requirements

Each area municipality will accept municipal system alteration applications proposing sewage works that pose a significant threat to drinking water provided the following are submitted with each application:

- i) Proponent: The proponent must outline how the proposed works will be managed to mitigate the contamination of sources of drinking water through the construction, design and operation of the proposed activity.
- ii) It is the applicant's responsibility to know what SPP prescribed instrument policies apply to their activity. Within the Regional Municipality of Waterloo, the SPP requires that any project within Wellhead Protection Areas A and B use enhanced construction practices for transport pathways to ensure that they do not contribute to the creation of significant drinking water threats. Subsurface excavation within these areas, that may excavate into or through aquitards overlying municipal aquifers, should be planned and carried out with appropriate mitigative measures to ensure that the aquifer intrinsic vulnerability is not increased.
- iii) If the proposed activity for sewage works is located in a wellhead protection area or intake protection zone with a vulnerability score of 8 or above, it may be considered a significant drinking water threat. In general, this would apply to construction involving any sanitary sewers that are located within a 100m security area around any Regional water supply well. Municipal system alteration applications for sanitary sewers that pose a significant threat to drinking water may be submitted to the respective area municipality but must comply with the following conditions:
 - a) Contractors shall provide a Spill Contingency Plan as part of their Health and Safety Plan;
 - b) Pipe material shall be HDPE, PVC or PVCO for watermains as per Table C.2.1 of the DGSSMS;
 - c) Connections to manholes shall be in accordance with OPSS 407 Construction Specification for New Maintenance Hole, Catch Basin, Ditch Inlet, and Valve Chamber Installation - Section 407.07.13 Installation of Inlet and Outlet Pipes Into Concrete Structures c) Resilient Connector;

- d) Testing of the new sewers only shall be conducted in accordance with OPSS 410 Construction Specification for Pipe Sewer Installation in Open Cut - Section 410.07.16.04.03 Low Pressure Air Testing modified for 0kPa pressure loss; and
 - e) Closed-circuit television inspections on new sewers only shall be carried out at completion of construction and at the end of the maintenance period in accordance with OPSS 409 Construction Specification for Closed-Circuit Television (CCTV) Inspection of Pipelines. Closed-circuit television inspections on existing sewers shall include an additional inspection six (6) months after completion of construction.
- iv) In addition, if the proposed activity for sewage works is located within an Issue Contributing Area for nitrate and the vulnerability score is greater than 6, the ECA applications must include spill contingency plans.

B.2 Watermains

B.2.1 Watermain Classification – Region of Waterloo

B.2.1.1 General

Watermains within the Region of Waterloo are classified into 2 broad categories:

- Regional
- Local

Regional watermains are furthermore classified into four subcategories:

- i) Transmission
- ii) Trunk Dual-Purpose
- iii) Arterial Dual-Purpose
- iv) Non-Potable

The purpose of the classification is to aid in maintaining the reliability, integrity and flexibility of key components in the water supply and distribution system.

Within the Region of Waterloo, the Region, in consultation with the Municipality, will classify new watermains. The watermain is classified by use and not by size.

Dual-Purpose Watermains are those that qualify as Regional Watermains yet allow service connections. Non-potable watermains transfer water not fully treated as defined under provincial regulations.

B.2.1.2 Regional Watermains

Regional Watermains constitute the skeleton (supply lines and related ancillaries) of the distribution system and satisfy one or more of the following cases:

- Watermains which connect water sources, storage or pumping facilities

- Watermains which cross pressure zone boundaries unless these watermains are controlled by special agreements with the Region and relevant area municipalities
- Watermains that include controlling devices (pressure regulating valves, motorized valves, etc.) with the exception of devices that control a local watermain
- Watermains that include bulk water meters used for wholesale water billing
- Watermains that complete or will complete future major loops. A major loop is defined as watermains that branch from Regional watermains and "loop back" to Regional Watermains. The purpose of a major loop is to enhance the pressure and water supply in the looped area rather than to provide a ring distribution main.
- Watermains that include chlorine residual boosting facilities
- Watermains that provide a focal supplying node to development areas

B.2.1.3 Local Watermains

Local Watermains are those that do not satisfy the criteria for Regional Watermains. These watermains provide the majority of connections to customers.

B.2.1.4 Connection to Regional Watermains

B.2.1.4.1 Transmission Watermains

Private services and fire hydrants shall not be connected to Transmission Watermains. A parallel watermain, connection to other watermains, individual supply wells, etc. must be installed to service properties adjacent to Transmission Watermains. Only in very exceptional cases will these connections be allowed. Special arrangements must be made with the Region of Waterloo and it must be clearly demonstrated that an alternate supply is not available.

Watermains connecting to Transmission Watermains must utilize a suitable tee, cross fitting or anchor tee. An isolation valve must be installed on the interconnect as near as practical to the Transmission Watermain to minimize the likelihood that damage to the connecting main will interrupt the water supply in the Transmission Watermain. The Region of Waterloo must approve the interconnection locations; however, generally only up to two (2) connections (tee and/or cross) will be allowed per kilometre of Transmission Watermain.

Existing private service and fire hydrant connections made prior to the classification of the watermain will be grandfathered until the time that the roadway and/or the watermain system are reconstructed. At which time, the connection will be removed and suitably connected to another water source. The Region may also undertake to remove connections and will at that time provide an alternate water source.

Although connections may exist on a Transmission Watermain (grandfathered or special conditions), it in no way implies that future connections will be allowed to the watermain.

B.2.1.4.2 Trunk Dual Purpose Watermains

One private service connection is permitted per 30 m of watermain. There is no limitation on the connection of fire hydrants and branch watermains.

B.2.1.4.3 Arterial Dual-Purpose Watermains

There are no connection limitations.

B.2.1.4.4 Non-Potable Watermains

Non-potable watermains are those that transfer water that has not been fully treated to regulated standards. Included in this classification are watermains transferring water from the source (well, river) to the treatment plant and watermains utilized to achieve the minimum chlorine contact time. Connections shall not be made to watermains designated non-potable.

B.2.2 Water Demand

B.2.2.1 Definitions

B.2.2.1.1 Average Day: The total amount of water demanded within a certain time period, usually one year, divided by the number of days within that time period.

B.2.2.1.2 Maximum Day: The average water demand over the day (midnight to midnight) of highest water demand within any one year.

B.2.2.1.3 Minimum Hour: The smallest short-term (1 hour) demand. Without accurate records, this value can be taken as zero (0) in small systems or as the smallest hourly demand over a typical average day in large systems.

B.2.2.1.4 Peak Hour: The highest short-term (1 hour) demand within a system not including fire flow. The peak hour is normally the highest hourly demand on the maximum day.

B.2.2.1.5 Domestic: Any non-fire water use.

B.2.2.2 Domestic

Wherever available, the Engineer shall use historical data, as supplied by the Region of Waterloo and the Municipality, to establish the Peaking Factors and Unit Consumption Rates. Based on historic information, the specific usage rate is 225 L/c/d as outlined in the Region's "Water Supply and Distribution Optimization Master Plan, 2015". For the City of Guelph, use the water demands as utilized in the City's Hydraulic Water Model.

B.2.2.3 Fire Flow

The fire flow requirements shall be determined in accordance with the current issue of "Water Supply for Public Fire Protection", Fire Underwriters Survey.

B.2.2.4 Design Period

The Design Period for watermain sizing purposes shall be 40 years, using the ultimate land use as predicted by the Municipality, Planning Department, and as shown in the Region of Waterloo's and Area Municipality's Official Plan.

B.2.2.5 Peaking Factors

The peaking factors used to calculate minimum hour, maximum day and for peak hour must be based on:

- Historical information
- Water Supply and Distribution Optimization Master Plan
- Ministry of the Environment and Climate Change guidelines
- As directed by the municipality

B.2.3 Hydraulic Analysis

B.2.3.1 Friction Factors

The following “C” friction factors, which include an allowance for age, shall be used for the following materials:

- PVC/PVCO: 150
- DI: 130
- CPP: 140
- HDPE: 140

If the watermain material has not been determined at the time of watermain sizing, a “C” factor of 130 shall be used.

B.2.3.2 Nominal vs. Actual Diameter

The nominal diameter can be used for general water distribution system design. The actual inside diameter shall be used though for the design of critical infrastructure (i.e. Regional Watermains).

The actual inside diameter shall be used for the design of HDPE watermains.

B.2.3.3 Capacity

All watermain distribution systems must be able to transfer the larger of maximum day plus fire or peak hour.

B.2.3.4 Maximum Velocity

The maximum velocity in the watermain under all flow conditions shall not exceed 5.0 m/s.

For Regional watermains, the maximum velocity under all flow conditions shall not exceed 1.5 m/s.

B.2.3.5 Transient Pressure

All watermains shall be designed to withstand the maximum operating pressure plus the transient pressures to which the watermain will be subjected. As a minimum, the pipe and joint strength shall be such that it can withstand the pressure surge resulting from an instantaneous stoppage of a water column moving at 0.6 m/s.

The minimum material classes specified for watermains in Part C – Materials tend to be adequate for normally interconnected water distribution systems. A transient pressure analysis however must be conducted for Regional Watermains, long single feed watermains, and those watermains designated by the Chief Municipal Engineer.

B.2.4 Pressure

B.2.4.1 Pressure Zone Delineation

The Water Services Division of the Region of Waterloo is responsible for general pressure zone delineation and the resultant pressures within the Region of Waterloo. Within the City of Guelph, the Infrastructure Planning Group is similarly responsible.

B.2.4.2 Boundary Conditions

The boundary conditions (i.e. available pressure and flow) for new watermains and water distribution systems can be obtained by field testing and/or from the Municipality. Field testing the water distribution system shall only be conducted with the approval and assistance of the Municipality. The Region of Waterloo (Water Services) maintains a hydraulic model of the trunk system for select communities within its borders and the City of Guelph (Infrastructure Planning) maintains a hydraulic model of its system.

B.2.4.3 Preferred Pressure Range

The preferred design pressure ranges are:

Average Day and Maximum Day: 350 kPa (50 psi) to 550 kPa (80 psi)

Minimum Hour and Peak Hour: 275 kPa (40 psi) to 700 kPa (100 psi)

Pressures outside of these ranges are acceptable to the limits described below; but, are not desirable.

B.2.4.4 Minimum Pressure

B.2.4.4.1 Non-Fire Scenarios

The minimum pressure under any non-fire demand scenarios shall not be less than 275 kPa (40 psi).

B.2.4.4.2 Fire Scenarios

Under no circumstances shall the minimal residual pressure during Maximum Day plus Fire scenarios be less than 140 kPa (20 psi) at any location in the water distribution system.

B.2.4.4.3 Emergency Conditions

The minimum pressure under emergency conditions is 140 kPa (20 psi).

B.2.4.5 Maximum Pressure

The maximum static pressure in the watermain system should not exceed 700 kPa (100 psi) under any scenario.

B.2.4.6 In-Line Booster Pumps

In those areas where the pressure at the centreline road elevation will be lower than 275 kPa (40 psi), in-line booster pumping systems may be utilized. This could take the form of a system booster pumping station or individual booster pumps with pressure tanks. The use of booster pumps must be approved by the Municipality and, if within the Region of Waterloo, the Region of Waterloo as well.

If the booster pumping station is designed to supply fire flow, the station shall be equipped with standby power. The booster pumping station shall be designed to the Region of Waterloo or the **City of Guelph's** standards as applicable. The design of booster pumping stations is outside of the scope of this document.

Individual booster pumps and pressure tanks shall be designed for the application. A backflow preventer in accordance with CAN/CSA-B64-10 shall be installed immediately downstream of the meter.

B.2.4.7 Individual Pressure Reducing Devices

Where the topography is such that pressures at the centreline road elevation will be greater than 550 kPa (80 psi), an individual pressure reducing device will be required on each water service.

In lieu of individual pressure reducing devices, the creation of a new sub-pressure zone will be considered by the Region of Waterloo and the area municipality only under exceptional circumstances.

B.2.4.8 Design Pressure Location

For design purposes, the pressure is measured at the centreline road elevation. Under fire flow conditions the pressure is considered to be located at the centreline road elevation at the hydrant tee.

B.2.5 Pipework

B.2.5.1 Material

Materials shall be as per Part C – Materials. On a project specific basis, the Chief Municipal Engineer may specify or allow alternate materials (e.g. in the case of environmentally impacted soils, or sensitive areas).

The Engineer is responsible to ensure that the class or pressure rating of pipe is not exceeded given the expected dead and live loadings and anticipated maximum water pressures.

The transition / connection from HDPE pipe to PVC, PVCO, ductile, cast iron, etc. shall be designed by the Engineer. The engineer shall take into account the following but not limited to: performance of the different materials, American Standard of Testing and Material specification (ASTM), and Plastic Pipe Institute handbook of Polyethylene pipe, OPSS / OPSD, manufacture specifications, etc.

B.2.5.2 Location

The watermain shall be located as shown on the Municipality's typical cross-sectional drawings.

B.2.5.3 Diameter

B.2.5.3.1 General

The watermain diameter shall be sized in accordance with a Water Distribution Report prepared for the area under consideration, submitted and approved by the Chief Municipal Engineer.

The diameter of a permanent dead-end watermain shall not exceed the diameter of its feeder watermain.

B.2.5.3.2 Minimum

The minimum watermain diameter shall be 150 mm.

In Industrial, Commercial and high-density residential areas and in areas specified by the Chief Municipal Engineer the minimum diameter shall be 300 mm. The Design Engineer shall contact the Chief Municipal Engineer for clarification if necessary.

B.2.5.3.3 Maximum

The maximum watermain diameter for cul-de-sacs and other permanent dead-end watermains shall be 200 mm, and 300 mm for industrial, commercial and high-density residential areas unless it can be demonstrated and approved by the Chief Municipal Engineer that a unique demand condition exists that necessitates a larger watermain.

The Regional Municipalities **do not** accept 250 mm, 350 mm or 400 mm diameter size watermain piping attached to the distribution system.

B.2.5.4 Depth of Cover

The depth of cover from finished grade to the top of pipe shall not be less than that described below.

- 300 mm diameter and smaller: 2.0 m
- 450 mm diameter and larger: 1.8 m

When the above noted minimum depths are not achievable, watermains shall be insulated. Insulation must be designed/verified by a Licensed Engineering Practitioner in the Province of Ontario.

Watermains designed deeper than 2.0 m shall require approval of the Municipal Engineer. Consideration should be given to valve placement so that the valves are not installed at the deeper sections. For mainline valves and hydrant valves deeper than 2.5 m, valve extenders shall be installed.

B.2.5.5 Vertical Connection to Existing System

In the event that the existing watermain has less than 1.8 m of cover, vertical bends shall be utilized as necessary at the construction limits to connect the new watermain (at proper depth) to the existing system. This method of connection facilitates the future lowering of the remainder of the existing watermain.

Sweeping vertical pipe joint deflections shall not be used.

B.2.5.6 High Points

High points shall be avoided unless an escape route for trapped air is provided.

For local watermains, services will generally provide an escape route for trapped air but it is preferred to locate fire hydrants at high points. Air release valves shall not be installed on local watermains without the approval of the Chief Municipal Engineer.

For Regional Watermains, the preferred method is through the use of a combination air and vacuum release valves. Where possible, an interconnection to the local system and strategic hydrant placement can be used as an appropriate escape route for trapped air.

B.2.5.7 Minimum Slope

To facilitate the movement of trapped air and to avoid localized high and low points, the preferred minimum slope for watermains is 0.5%. Slopes less than 0.5% will be submitted to the Chief Municipal Engineer for approval.

B.2.5.8 Dead-end Mains

Dead-end watermains are to be avoided wherever possible. Where dead ends watermains cannot be avoided, the maximum length of a permanent dead-end watermain is 150 m.

A fire hydrant must be located at the end of cul-de-sacs and other permanent dead-ends. A fire hydrant must be installed in-line at temporary dead-ends. An acceptable alternative is to provide a plug on the main line leg of the hydrant tee and install a fire hydrant in its permanent location. A temporary plug or blow off may be acceptable at the approval of the Chief Municipal Engineer.

B.2.5.9 Cul-de-sac Servicing

In the municipalities of **Cambridge, North Dumfries, Waterloo, Wellesley** and **Woolwich** the servicing of a cul-de-sac shall be such that the main will be extended only to the bulb of the cul-de-sac, and a 50mm diameter service main will be looped around the bulb to service the individual houses. Refer to the respective municipality for additional information and drawings.

B.2.5.10 Minimum Clearance to Sewers

The clear separation between watermains and sewers shall be 2.5m clear separation as per MECP requirements "Watermain Design Criteria for Future Alterations Authorized under a Drinking Water Works Permit."

B.2.5.11 Thrust Restraint

Mechanical joint restraints shall be installed to restrain movement of the watermain. Concrete thrust blocks to be used in addition to mechanical restraints at the discretion of the Chief Municipal Engineer.

Both mechanical restraints and concrete thrust blocks shall be used at hydrant installations both at the tee and behind the barrel. The limits for which mechanical joints restraints must be

installed shall be clearly indicated on the Construction Drawings. The **City of Waterloo** does not require the installation of thrust blocks, all joints are to be mechanically restrained.

The restraining joint and pipe design shall be based on transferring thrust through the pipe to the surrounding material. A safety factor of 1.5 must be used to calculate restraint length for Ductile Iron and PVC watermain material. A safety factor of 1.5 must be used to calculate restraint length for Concrete Pressure Pipe using methods outlined in AWWA M9.

On all mains greater than 300 mm diameter, and in areas where there is "disturbed" soil, particularly reconstruction projects or congested works, mechanical joint restraints shall be installed and specified on the Construction Drawings.

B.2.5.12 Soil Settlement Areas

On areas subject to possible future soil settlement, the bedding design must minimize pipe movement and mechanical joint restraints must be installed to the limits of the possible settlement area. This requirement may be waived if it can be demonstrated that future settlement will not occur.

B.2.6 Water Quality

B.2.6.1 Minimum Chlorine Residual

The minimum chlorine residual as mandated by the Ministry of the Environment, Conservation and Parks is 0.25 mg/L for combined chlorine **or** 0.05 mg/L for free chlorine at any point in the distribution system. The combined chlorine residual is the total chlorine residual minus the free chlorine residual. For development that is approved under a Subdivision Agreement, the Developer shall provide a Chlorine Residual Maintenance Plan, see sheet E-T2.

B.2.6.2 Design Considerations

Although the Municipality has primary responsibility to ensure that the minimum chlorine residuals are maintained in the distribution system, the distribution system must be designed to mitigate the degradation of chlorine residuals. The Chief Municipal Engineer reserves the right to require watermain looping and/or automatic flushing devices to facilitate the maintenance of chlorine residuals.

B.2.7 Hydrants

B.2.7.1 Maximum Spacing

The maximum spacing between fire hydrants as measured along the roadway centreline is as follows:

- Residential 150 m
- Industrial, Commercial & High Density Residential 90 m
- Watermains not fronting lots 300 m

The Chief Municipal Engineer:

- Will determine if fire hydrants are required along watermains not fronting lots

- Reserves the right to request additional fire hydrants
- May waive the requirement to provide fire hydrants fronting vacant properties

B.2.7.2 Lead Size

The minimum hydrants lead size is 150 mm. On a site specific basis, the Chief Municipal Engineer may request a larger hydrant lead size.

The valve and boot must be the same size as the lead. A reducer shall not be utilized at the hydrant boot.

B.2.7.3 Location

Fire hydrants shall be installed at the end of cul-de-sacs and other permanent dead end watermains. For municipalities that use a 50mm loop at the end of cul-de-sacs, the hydrant shall be located just short of the bulb of the cul-de-sac such that the hydrant coverage can be maintained.

The preferred locations for the fire hydrants are:

- At street intersections
- On the same side of the road as the watermain
- Consistently on the same side of the road as existing and future fire hydrants
- At the dividing property line between adjacent properties
- At high points
- At low points

During road reconstruction projects if an adjacent property has an existing fire hydrant which is located for a specific fire suppression system for a private building then the new fire hydrant that is part of the road reconstruction shall be located within 45m of existing Siamese or similar fire suppression connection(s) on buildings in accordance with the latest edition of the Ontario Building Code or approved site plan. Fire hydrant leads must be installed perpendicular to the road and/or the watermain.

At street intersections, the **City of Cambridge** requires hydrant valves to be located with the watermain valves at the intersection.

B.2.7.4 Bends

Bends in fire hydrant leads will not be allowed unless site conditions warrant and with written approval of the Chief Municipal Engineer.

B.2.7.5 Minimum Clearance

The minimum clearance from above ground obstructions to fire hydrants shall be as follows:

- Behind 0.6 m

- Each Side with a port 2.0 m
- Each Side without a port 1.0 m
- Front no obstructions between the street and the hydrant face

The installation of bollards shall be as directed by the Municipality.

B.2.7.6 Restraints

Hydrants leads, including valves and joints shall be fully restrained from the watermain to the property line. The concrete thrust blocks and mechanical restraints shall be as per SSMS E2-01.

B.2.8 Isolation Valving

B.2.8.1 Size

The valve shall be the same size as the main.

B.2.8.2 Location

Valving must satisfy the following location criteria:

- 2 valves at tee intersections
- 3 valves at cross intersections
- Valve on each side of a railway crossing a minimum of one pipe length away from casing pipe.
- Valve on each side of any water stream a minimum of one pipe length away from casing pipe or as directed by the Engineer.
- Separating hydrants such that no two adjacent hydrants will be out of service at one time unless otherwise directed by the Municipality. Valving at intersections shall be located in-line with the extension of the property line of the intersecting through street, unless otherwise directed by the Chief Municipal Engineer. Contract Administrator / Contractor to ensure that the valve doesn't conflict with other utilities and /or infrastructure.

City of Cambridge requires 3 valves at the tee and 4 valves at the cross

B.2.8.3 Maximum Spacing

In addition to the valving requirements outlined above, the maximum spacing for isolation valves shall be as listed for the following watermain diameters:

- 300 mm diameter and smaller spacing = 300 m
- Larger than 300 mm diameter spacing = as directed by the Chief Municipal Engineer

B.2.8.4 Direct Bury

All valves shall be direct buried as per SSMS E2-02, unless the Chief Municipal Engineer specifically requires a chamber to be provided.

B.2.8.5 Minimum Clearance

The minimum clearance from above ground obstructions to valves is 2.0 m.

Avoid installation of valves in curbs, ramps and sidewalks.

B.2.8.6 Valve Depth

A standard valve key (+/-2.1m) must be able to operate the valve. If the watermain is greater than 1.8m in depth to the top of valve nuts, extensions/ highheads need to be installed on the valve.

Long valve box top section to be used to ensure a minimum of 450 mm of thread showing inside, measured down inside from the top of the top section to the extension or base.

B.2.9 Combination Air & Vacuum Release Valves

B.2.9.1 Utilisation

Air and Vacuum Release Valves shall be utilized in watermains in situations where it is possible for air to accumulate or a vacuum to develop and an alternate means for release is not available (i.e. services or fire hydrants) to remove the air. The valves shall be located in accordance with best design practices. This generally includes supply watermains with localized high points, long stretches of flat or gently sloping watermain or at changes in grade.

In general terms, Air and Vacuum Release Valves shall be of the combination configuration. The sole use of either an air release or vacuum release valve must be dictated by the situation and approved by the Chief Municipal Engineer.

Watermains servicing adjacent lots generally do not require air and vacuum release valves because air can escape or enter through the services.

A blow off or fire hydrant is an acceptable alternate means of air or vacuum release in temporary situations with the approval of the Chief Municipal Engineer.

The Region of Waterloo will consider the application of chamberless combination air and vacuum release valves for use on transmission watermains, to be approved on a case by case basis.

B.2.9.2 Watermain Profile

The Engineer, through a cost-benefit analysis, shall consider reducing the number of air and vacuum release valves by altering the profile of the watermain.

B.2.9.3 Sizing

Air Release and Vacuum Release valve and piping to be designed and sealed by a professional engineer in accordance with E02-12.

B.2.10 Drain Chambers**B.2.10.1 Utilisation**

Drain chambers are required where the normal methodology of watermain dewatering is not appropriate due to the watermain size or location. Watermains smaller than 450 mm will generally not require a drain chamber, however, a long downhill gradient without an isolation valve or fire hydrant for bulk draining may necessitate a drain chamber.

With the written approval of the Chief Municipal Engineer, a fire hydrant may be installed with the intention that the watermain will be drained with a hydrant barrel pump.

B.2.10.2 Location

Drain chambers must be located at the low points of the watermain profile. Consideration should be given to locating low points adjacent to appropriate discharge locations (i.e. near catchbasin)

B.2.11 Flushing and Swabbing Ports**B.2.11.1 Utilisation**

Flushing and swabbing ports shall be considered for watermains over 300 mm. The Engineer shall contact the Chief Municipal Engineer to determine if a swab launching and/or swab retrieval chamber is required or is available nearby.

B.2.12 Services**B.2.12.1 Sizing**

The minimum nominal service size shall be 25 mm.

The allowable service sizes are 25 mm, 50 mm, 100 mm, 150 mm etc. in 50 mm increments. Multi-block minimum service should be 150 mm (for onsite hydrants). Services larger than the minimum size for the Municipality shall be sized in accordance with AWWA M22 'Sizing Water Service Lines and Meters'. The Chief Municipal Engineer must approve services sized larger than 300 mm or alternate service sizing.

The service size shall not exceed the diameter of the watermain.

B.2.12.2 Location

The service shall be located as detailed on the Municipality's typical servicing and/or road cross-section drawings unless otherwise approved.

Water services must be installed perpendicular to the road and/or the watermain wherever practical and within the lot frontage.

B.2.12.3 Number of Services per Property

No more than one individual property shall be serviced by the same service regardless of ownership.

In situations where a fire service is required due to infilling or site development after the water distribution system has been installed, private hydrants can be supplied by a separate service at the discretion of the municipality as long as it can be demonstrated that the fire line service will not be interconnected now or later with the domestic water system.

In the case of multi-unit blocks, on-site servicing can be arranged to the property owner's convenience, however, there shall only be one service from the municipal system.

In unique circumstances and with the approval by the Chief Municipal Engineer, more than one service may be allowed to one property. However, a testable backflow preventer in accordance with CAN/CSA-B64-10 shall be installed on each service to eliminate the possibility of system flow through private property.

B.2.12.4 Restraints

Services 100 mm and larger, including valves, joints and bends, regardless of size shall be fully restrained from the watermain to the property line.

B.2.12.5 Bends

Bend fittings shall be avoided wherever possible.

B.2.12.6 Valving

For services 50 mm diameter and smaller, all services shall have two isolation valves. One valve shall be installed immediately adjacent to the watermain (main stop) and buried, and another valve shall be installed at the property line or easement limit (curb stop) and a service box provided to finished grade.

For services 100 mm and larger, the Engineer shall contact the Municipality having jurisdiction regarding the number, location and need for valves and valve boxes. Two valves shall be required for services 100 mm and larger. One valve is to be at the main and the other valve is to be at the property line. The main stop or valve, regardless of size, shall be fully restrained to the watermain, preferably through the use of an anchor tee, joint restraint, or bolted connection. The **City of Waterloo** only requires one valve installed at the main for services 100mm and larger.

B.2.12.7 Metering

The metering of water use shall be in accordance with the Municipality's standard.

B.2.12.8 Allowance for Future Servicing

If the location of future servicing is in doubt then the servicing can only be installed with the written approval of the Chief Municipal Engineer.

B.2.12.9 Electrical Grounding

On reconstruction or local improvement projects where existing structures will be serviced by a replacement or new water distribution system, the design Engineer shall determine if the electrical grounding systems are connected to the water service. If so, appropriate measures must be taken to ensure that electrical grounding systems are not compromised. Possible

solutions include using copper services or installing new grounding rods or plates (see the Electrical Safety Code).

B.2.12.10 Service Box Extensions

In the event that water service boxes must be raised beyond their extension height, only screwed couplers will be accepted. Extensions using set screws or other means will not be accepted.

B.2.13 Geotechnical Report

B.2.13.1 Requirements

A geotechnical report must be submitted to the Chief Municipal Engineer as part of the design of the watermain unless otherwise waived by the Chief Municipal Engineer. As a minimum, recommendations must be made regarding the watermain bedding, thrust restraints, trench dewatering and corrosion protection based on soil resistivity testing, including corrosiveness of the soil, and soil stability. The results of the soil resistivity testing must be included in the report with recommendations as to anode type and spacing. Where the geotechnical engineer has recommended filter cloth wrapping for clear stone bedding design drawings shall specify but not limited to locations, filter cloth material/product and details sections.

The geotechnical report shall also include test results and recommendations for the use and/or disposal of adversely impacted soils, such as from sodium and petroleum products, in accordance with current regulations.

B.2.14 Corrosion Protection

B.2.14.1 Non-Metallic Watermain

Non-metallic watermain with metallic valves and fittings and non-metallic service laterals, shall have one zinc Z-24-48 (24 lb) anode attached to the tracer wire and to a metallic valve and fitting. Spacing is to be based on soil resistivity results and the corrosiveness of the soil. Maximum spacing between anodes shall not exceed 100 meters along the length of watermain. In the **City of Waterloo and City of Guelph** anodes are **not** to be attached to the tracer wire (**See Section D.2.5.6**). **In Township of Woolwich a max. 50m spacing between anodes is required.**

The anode spacing shall be clearly shown on the Construction Drawings and Record Drawings. In addition, a tabular listing of the stations at which the anodes are to be installed shall be provided.

Corrosion Protection for CPP shall be considered on a project by project basis. See **Section D.2.5.6** for additional information.

B.2.14.2 Metallic Watermain

As part of the geotechnical report, the resistivity and corrosiveness of the soil must be determined.

Where metallic watermains are to be installed, an appraisal must be done to determine if corrosion protection is required. This appraisal shall be performed using the 10-point soil

evaluation procedure as described in AWWA C105 Appendix. If the 10-point soil evaluation establishes a need for corrosion protection, the necessary anode spacing shall be clearly shown on the Construction Drawings.

Approved methods for corrosion protection of Ductile Iron watermain and fittings are:

- Sacrificial anodes
- Petrolatum tape systems (refer to section D.2.5.10, Wrapping)
- Polyethylene encasement

B.2.15 Watermain Identification

All non-potable watermains will be identified in the trench with an underground warning tape placed on the top of the pipe bedding along the centreline of the pipe.

B.3 Sanitary

B.3.1 Pipework

B.3.1.1 Design flow

The quantity of sewage flow for residential area shall be calculated on the following basis:

- The design flow of sewage including extraneous flows
- Allowance shall be made in the designed capacity of the sewer to provide for future sewage requirements
- Flow data sheets and plans showing drainage area must accompany plan and profile submission
- In accordance with MECP approval requirements
- Where the MECP Design Criteria is not met, the area municipality does not have the authority to approve the alteration and therefore, the project will require direct application to the MECP.

B.3.1.2 Flow Calculations

Except in the **City of Kitchener** and **Township of Woolwich**, sanitary sewer flows are to be determined using the following design criteria. For Kitchener and Woolwich refer to the Chief Municipal Engineer.

B.3.1.2.1 Residential

- Average flow – 275 L/c/d
- Use actual or projected populations based on information (zoning or otherwise) to be provided by the Municipality
- Peak the average flow using the Harmon Formula

$$F = 1 + \frac{14}{4 + \sqrt{P}} \quad (P = \text{Population}/1,000)$$

- Daily domestic flows to be provided from municipal sanitary sewer master plans.

B.3.1.2.2 Industrial

- Average flow: 0.40 l/s/ha.
- Use higher design flows for point sources known to have significantly greater flows than the average design allowance.
- Use actual flows for large known discharges.
- Use peaking factor as per MECP guidelines. In the absence of such information, peak sewage flow rates shall be based on an individual assessment of expected peak flow rates or actual flow records whenever possible. A peaking factor between two (2) and four (4) may be used based on the designer's best judgement in cases where data is unknown. Commercial Average flow – Core = 0.95 l/s/ha; Shopping Mall = 0.3 l/s/ha; General = 0.5 l/s/ha. Use higher design flows for point sources known to have significantly greater flows than the average design allowance.
- Use actual flows for large known discharges.
- Peak using a factor of 2.5.

B.3.1.2.3 Institutional

- 0.25 L/s/ha for institutional uses
- 0.015 L/s/bed for hospitals

B.3.1.2.4 Other Miscellaneous Average Flow Rates

In accordance with MECP Design Guidelines.

B.3.1.2.5 Extraneous Flows

Add an inflow and infiltration allowance of 0.25 l/s/ha to account for wet weather flows, or as directed by the Municipality.

B.3.1.3 Design Flow Calculations

Design flow calculations for sanitary sewer systems shall be completed on Sanitary Sewer Design Sheets in accordance with MECP Design Guidelines and the MECP Pipe Data Form.

B.3.1.4 Minimum Pipe Size

In accordance with MECP Design Guidelines.

B.3.1.5 Manning's "n"

The value of "n" using the Manning formula shall be 0.013 for all pipe materials.

B.3.1.6 Pipe Slope

The minimum gradient for the first reach of permanent dead end sewers shall be 1%.

For sewers other than the first reach of permanent dead end the minimum slope shall be 0.5%, unless otherwise approved by the Chief Municipal Engineer.

B.3.1.7 Flow Velocities

In accordance with MECP Design Guidelines.

B.3.1.8 Selection of Bedding and Class of Pipe – Rigid Pipe

Rigid sanitary sewer pipe is to be designed to withstand all earth loads, superimposed loads and hydraulic loads placed on it in accordance with methods provided by manufactures and suppliers such as the "Concrete Pipe Design Manual" produced by the Ontario Concrete Pipe Association (OPCA).

The 0.3 mm crack, three edge bearing strength shall be used as the design criteria as specified in the CSA standards on concrete pipe. For non-reinforced pipe, a factor of safety of 1.5 must be used.

Pipe strength design calculations are to be completed. The class of bedding type and pipe shall be noted on the plans. If transition width is not used for design, the design width of all trenches shall be specified on the construction drawings. In case the actual trench width exceeds the design width, it must be noted that the Contractor shall be responsible for the supply of additional bedding and/or stronger pipe.

B.3.1.9 Selection of Bedding and Class of Pipe – Flexible Pipe

Flexible sanitary sewer pipe shall be designed so as to accommodate external dead and live loading (i.e. Traffic, soil, ground water changes, frost actions, soil settlement, etc.) imposed on it in accordance with the criteria and methodology as outlined in the current version of the MECP Design Guidelines.

Pipe strength design calculations shall be completed and provided to the Chief Municipal Engineer for review. Calculations shall include an appropriate safety factor. Pipe and bedding type class shall be noted on the construction drawings.

B.3.1.10 Pipe Depth

The obvert shall be a minimum of 2.8 metres below the final road grade.

For depths over 5.0 m, a secondary collection system may be required and shall be approved by the Chief Municipal Engineer. A secondary collection system may be installed directly over the deep trunk sewer.

Sanitary sewers shall be installed at sufficient depth (greater than frost penetration, 1.5 m) to prevent freezing, if this is not achievable, sewers shall be insulated. Insulation must be designed/verified by a Licensed Engineering Practitioner in the Province of Ontario.

B.3.2 Maintenance Holes

B.3.2.1 Structure

Maintenance holes 3000 mm and smaller shall be precast concrete.

B.3.2.2 Spacing

The maximum spacing for maintenance holes shall be as follows for the sewer diameters indicated:

- 200 mm to 450 mm 90 m
- Larger than 450 mm to 900 mm 120 m
- Larger than 900 mm at approval of Chief Municipal Engineer

B.3.2.3 Size

The maintenance hole shall be sized to receive pipes as per SSMS standard drawing. The minimum maintenance hole size is 1200 mm diameter. See standard drawing E1-02.

B.3.2.4 Drop Inlet Structures

For new maintenance holes requiring a drop inlet structure, the drop structure shall be an external drop structure provided in accordance with MECP Design Guidelines and OPSD 1003.01 (external). For retrofit on existing maintenance holes, and internal drop structure OPSD 1003.031 (internal) may be approved by the Chief Municipal Engineer.

Note: MECP guideline applies for an invert difference of 0.61 m.

The **City of Kitchener, City of Cambridge, City of Guelph** and **Township of Woolwich** only permit external drop inlet structures.

B.3.2.5 Safety Grates

For maintenance hole depths between 5.0 and 10.0 m, a safety grate must be installed at the mid-point. For maintenance hole depths between 10.0 and 15.0 m, a safety grate must be installed at the third points. Refer to OPSD 404.02.

B.3.2.6 Minimum Invert Drop

Where pipes enter and leave inline or at angles between 0° to 45°, the minimum drop from invert to invert across the maintenance hole shall be 0.030 m.

Where pipes enter and leave at angles of 45° to 90°, the minimum drop from invert to invert across the maintenance hole shall be 0.060 m.

B.3.2.7 Location

In accordance with MECP Design Guidelines and MECP Design Criteria.

B.3.2.8 Watertight Lids

Where there is a possibility for flooding, watertight lids shall be installed.

B.3.2.9 Flow Direction Changes

Changes in direction of flow through a maintenance hole greater than 90° will not be permitted.

In pipe sizes 675 mm or greater, a change in direction of flow through a maintenance hole greater than 45° shall not be permitted.

B.3.3 Services**B.3.3.1 Minimum Diameter**

The minimum service size is 100 mm for sanitary services.

B.3.3.2 Location

Services shall be installed perpendicular to the main wherever practical. There shall be only one sanitary service per property.

Sanitary services for single and semi-detached dwellings shall be at locations to the Municipality's standard.

B.3.3.3 Slope

The minimum service slope is 2%.

The maximum service slope is 8%.

B.3.3.4 Depth

The sanitary service invert at property line shall be 2.5 m below the finished grade.

B.3.3.5 Connections to Maintenance Holes

Sanitary service connections to maintenance holes are permitted. If the invert of the service entering the maintenance hole is 0.61 m or more above the lowest invert, a drop pipe must be installed to direct flow to the main channel.

B.3.3.5.1 Drop Structure

If the inlet of the sanitary service is 0.61 m above the lowest invert, an external drop inlet structure shall be provided to direct the flow into the channel in a manner to avoid splashing and the accumulation of debris on the benching. For retrofit on existing maintenance holes, an internal drop structure may be approved by the Chief Municipal Engineer. The maintenance hole shall be sized accordingly for internal drop; in particular a minimum internal clearance of 1200 mm is required. The **City of Kitchener, City of Cambridge, City of Guelph and Township of Woolwich** only permit external drop.

B.3.3.5.2 Main Line Connection

For 100 mm and 150 mm diameter services, factory made tees or wyes shall be used. Service saddles and “inserta-tees” are not permitted.

For services 200 mm and larger, a maintenance hole shall be installed within the road corridor or in the boulevard.

Under special circumstances, on specific road reconstructions, site plan projects (case by case) and intensification projects, service saddles may be used at the discretion of the Chief Municipal Engineer.

B.3.4 Curvilinear Sewers

Curvilinear sewers may be considered for sanitary sewers 600 mm diameter and larger.

B.3.5 Geotechnical Report

A geotechnical report must be submitted to the Chief Municipal Engineer as part of the design of the sanitary sewer unless otherwise waived by the Chief Municipal Engineer.

Recommendations must be made regarding the sanitary sewer bedding, trench dewatering, and pipe selection. Where the geotechnical engineer has recommended filter cloth wrapping for clear stone bedding design drawings shall specify but not limited to locations, filter cloth material/product and details sections.

The geotechnical report shall also include test results and recommendations for the use and/or disposal of adversely impacted soils, such as from sodium and petroleum products, in accordance with current regulations.

B.4 Storm

B.4.1 General

This section relates to storm sewers only and does not include requirements for storm water management. The Engineer is directed to the municipality’s standard and/or applicable governing conservation authority for design guidelines related to storm water management.

Where the MECP Design Criteria is not met, the area municipality does not have the authority to approve the alteration and therefore, the project will require direct application to the MECP.

B.4.2 Pipework

B.4.2.1 Design Flow Calculations

Design calculations for storm sewer systems shall be completed on Storm Sewer Design Sheets (see MECP Design Guidelines for Sewage Works and the MECP Pipe Data Form).

The quantity of storm flow shall be calculated using the Rational Method as follows:

$Q = kAIR$, where:

Q = flow (l/s)

k = 2.78

A = contribution area (ha)

I = rainfall intensity (mm/hr)

R = runoff coefficient

All storm sewers shall, as a minimum, be designed to a 5 year storm event, unless otherwise indicated.

For design purposes drainage areas shall be allocated to the up-stream end of the pipe run being sized.

B.4.2.1.1 Rainfall Intensity – Pipe Size Design Only

Values of rainfall intensity (I) shall be determined by: $I = A / (T_c + B)C$, where

Return Period	A	B	C
5 year	1593	11	0.8789

For detailed stormwater management design, please contact the local Municipality for rainfall intensity parameters.

B.4.2.1.2 Time of Concentration and Inlet Time

The time of concentration is the time required for flow to reach a particular point in the sewer system from the most remote part of the drainage area. It requires not only the travel time in the sewers, but also the inlet time or time required to flow overland into the sewer system. In addition to overland flow, the inlet time may also include components of open channel flow, gutter flow, and pipe flow, depending on the characteristics of the drainage area.

The MECP Guidelines state: “Inlet times should be calculated rather than relying upon arbitrary minimum or maximum times. The calculation should be based upon the overland flow route that will exist when the sewer system has been fully developed to the drainage limit. In the case of single-family residential areas, calculations will not be needed if a maximum inlet time of 10 minutes is used”.

As referenced in the MECP Design Guidelines, Inlet Times may be calculated in accordance with the “MTO Drainage Management Manual” (Ministry of Transportation, 1995-1997), Chapter 8, “Watershed Time of Concentration” where it is stated:

“Several methods are available to determine t_c . Two recommended approaches are:

- the Bransby Williams formula, and
- the Airport formula.

B.4.2.1.3 Bransby Williams Formula

In watersheds with a runoff coefficient, C , greater than 0.40, the Bransby Williams formula is one of the more accepted methods. The method considers area, length and slope of a watershed as follows:

$$t_c = 0.057 \times L / (S_w^{0.2} \times A^{0.1})$$

Where:

t_c = time of concentration, min

L = watershed length, m

S_w = watershed slope, %

A = watershed area, ha

B.4.2.1.4 Airport Formula

For watersheds where the runoff coefficient, C , is less than 0.40, the Airport formula gives a better estimate of t_c . This method was developed for airfields and is expressed as follows:

$$t_c = [3.26 \times (1.1 - C) \times L^{0.5}] / S_w^{0.33}$$

Where:

t_c = time of concentration, min

C = runoff coefficient

S_w = watershed slope, %

L = watershed length, m

When a watershed is made up of widely differing surfaces (e.g. grass and concrete), t_c can be calculated for each surface, and the individual values summed to give the overall value.

Manning's Formula

In addition to overland flow (as may be calculated above), the inlet time may also include components of open channel flow, gutter flow, and pipe flow. Manning's formula may be used for determining flow velocities and time of flow for open channel flow, gutter flow, and pipe flow components, as follows:

$$V = (1 / n) \times R^{2/3} \times S^{1/2} \text{ and Time of Flow (open channel, gutter or pipe) } = L / V$$

Where:

V = velocity in m/s

n = Manning's roughness coefficient

R = hydraulic radius, m (flow area / wetted perimeter)

S = channel slope, m/m

L = Length of open channel, gutter, or pipe segment

The total inlet time for a drainage area will be the sum of the time of flow for overland flow, open channel flow, gutter flow, and pipe flow, as applicable.

Other Methods

Other methods for calculating the inlet time are available and may be appropriate in certain applications. If a designer selects another method, references for the source of the method and appropriate supporting documentation about its applicability shall be provided.

B.4.2.1.5 Storm Drainage Area Drawing

As required in the MECP Pipe Data Form, storm water design calculations shall be accompanied and supported by a Storm Drainage Area Drawing showing all areas which drain into the proposed works, the physical area of each contributing drainage area in hectares, the runoff coefficient for each drainage area, and the storm water drainage path. In each case where inlet times are calculated, the calculation shall be supported by a graphical representation or other clear documentation of each flow component (overland, open channel, gutter and/or pipe) and the associated characteristics (length, slope, area, and/or Manning's roughness coefficient) utilized in the inlet time calculations.

B.4.2.1.6 Runoff Coefficient

Values of runoff coefficient (R) shall be as per the following table:

Land Use	Runoff Coefficient
Commercial	
Downtown / Suburban Shopping	0.9 – 1.0
Industrial	
- Downtown	0.9 – 1.0
- Suburban Industrial Parks	0.65 – 0.9
Residential	
- Apartments	0.6 – 0.80
- Row Dwellings / Townhouses	0.5 – 0.80
- Semi – Detached Downtown	0.45 – 0.65
- Detached Single Family Downtown	0.45 – 0.65
- Semi – Detached Suburban	0.45 – 0.65
- Detached Single Family Suburban	0.4 – 0.45
- Schools, Churches, Hospitals	0.4 – 0.75
- Parks / Open Space	0.15 – 0.35

Please contact the City of Guelph and Township of Wilmot for runoff coefficients.

B.4.2.2 Minimum Pipe Size

The minimum pipe size diameter for main lines shall be 300 mm.

B.4.2.3 Manning's "n"

The value of "n" using the Manning formula shall be:

Concrete, PVC, HDPE 0.013

Corrugated Steel Pipe (CSP) Plain Pipe 0.024

Paved Invert 0.020

B.4.2.4 Pipe Slope

The minimum slope for the first reach of permanent dead end sewer shall be 1%, where feasible. For sewers other than the first permanent dead end reach, use MECP Design Guidelines.

B.4.2.5 Flow Velocities

Minimum and maximum flow velocities shall be in accordance with MECP Design Guidelines. In the City of Kitchener contact municipality for flow velocities.

B.4.2.6 Selection of Bedding and Class of Pipe – Rigid Pipe

Rigid storm sewer pipe is to be designed to withstand all earth loads, superimposed loads and hydraulic loads placed on it in accordance with methods provided by manufactures and suppliers such as the "Concrete Pipe Design Manual" produced by the Ontario Concrete Pipe Association (OPCA).

The 0.3 mm crack, three edge bearing strength should be used as the design criteria as specified in the CSA standards on concrete pipe. For non-reinforced pipe, a factor of safety of 1.5 must be used.

Pipe strength design calculations are to be completed. The class of bedding type and pipe shall be noted on the plans. If transition width is not used for design, the design width of all trenches shall be specified on the construction drawings. In case the actual trench width exceeds the design width, it must be noted that the Contractor shall be responsible for the supply of additional bedding and/or stronger pipe.

B.4.2.7 Selection of Bedding and Class of Pipe – Flexible Pipe

Flexible storm sewer pipe shall be designed so as to accommodate external dead and live loading (i.e. Traffic, soil, ground water changes, frost actions, soil settlement, etc.) imposed on it in accordance with the criteria and methodology as outlined in the current version of the MECP. Design Guidelines.

Pipe strength design calculations shall be completed and provided to the Chief Municipal Engineer for review. Calculations shall include an appropriate safety factor. Pipe and bedding type class shall be noted on the construction drawings.

B.4.2.8 Pipe Depth

The obvert shall be a minimum of 1.5 m below the final road grade for new sewers and a desirable depth of 1.5 m for reconstruction projects.

In the **City of Guelph**, the obvert shall be a minimum of 2.7 m below the final road grade.

Storm sewers shall be installed at sufficient depth (greater than frost penetration, 1.5 m) to prevent freezing, if this is not achievable, sewers shall be insulated. Insulation must be designed/verified by a Licensed Engineering Practitioner in the Province of Ontario.

B.4.2.9 Curvilinear Sewers

Curvilinear sewers may be considered for storm sewers 600 mm diameter and larger only upon the written approval of the Chief Municipal Engineer.

B.4.2.10 Elliptical Sewers

Elliptical Pipe may be utilized for clearance and/or cover purposes.

B.4.2.11 Blind Connections

Blind connections using factory made tees are permitted for:

- Services less than 200 mm, or
- Services less than one third (33%) of the diameter of the main line sewer, or
- Catchbasin leads within road allowances for the **City of Cambridge** and **Guelph**
- Catchbasin leads within road allowances for the **City of Waterloo** when the storm main is 600 mm in diameter and larger

These requirements do not apply to rear yard catchbasins. A catchbasin maintenance hole shall be installed for rear yard catchbasins except in the **City of Guelph**.

B.4.2.12 Safety / Rodent Grates

Manufactured safety / rodent grates are required on open inlets and outlets 300 mm and larger, except in driveway culverts.

B.4.2.13 Head Walls

Head walls shall be used for 525 mm diameter and larger sewers, permanent pool or submerged conditions.

For outlets 450 mm diameter and smaller or driveway culverts, use OPSD 801.020

For outlets 525 mm diameter to 900 mm diameter, use OPSD 804.03 or OPSD 804.04.

For outlets greater than 900 mm in diameter, use OPSD 804.04.

A handrail as per OPSD 980.101 shall be installed around headwalls 0.6 m or larger in height.

B.4.3 Maintenance Holes

B.4.3.1 Structure

Maintenance holes 3000 mm and smaller shall be precast concrete.

B.4.3.2 Spacing

The maximum spacing for maintenance holes shall be as follows for the sewer diameters indicated:

- 300 mm to 900 mm 90 m
- Larger than 900 mm and smaller than 1350 mm 120 m
- 1350 mm and larger at approval of Chief Municipal Engineer

B.4.3.3 Size

The maintenance hole shall be sized adequately to receive pipes as per SSMS Standard Drawing. The minimum maintenance hole size is 1200 mm diameter.

B.4.3.4 Tee Maintenance Holes

Tee maintenance holes are permitted provided that:

- No change in slope
- No change in direction
- 1200 mm or larger pipe

Fabricated bends, reducers and increasers may be used immediately adjacent to tee maintenance holes.

B.4.3.5 Drop Inlet Structures

For new maintenance holes requiring a drop inlet structure, the drop structure shall be an external drop structure provided in accordance with MECP Design Guidelines and OPSD 1003.01 (external). For retrofit on existing maintenance holes, and internal drop structure OPSD 1003.031 (internal) may be approved by the Chief Municipal Engineer.

Note: MECP guideline applies for an invert difference of 0.61 m.

The **City of Kitchener, City of Cambridge, City of Guelph** and **Township of Woolwich** only permit external drop inlet structures.

B.4.3.6 Location

Location shall be in accordance with MECP Design Guidelines and MECP Design Criteria.

B.4.3.7 Safety Grates

For maintenance hole depths between 5.0 and 10.0 m, a safety grate must be installed at the mid-point. For maintenance hole depths between 10.0 and 15.0 m, a safety grate must be installed at the third points. Refer to OPSD 404.02.

B.4.3.8 Minimum Invert Drop

Where pipes enter and leave in line, the drop from invert to invert across the maintenance hole shall be a minimum of the slope of the upstream pipe.

Where pipes enter and leave at angles deflected 0° to 45°, the minimum drop from invert to invert across the maintenance hole shall be 0.030 m.

Where pipes enter and leave at angles deflected 45° to 90°, the minimum drop from invert to invert across the maintenance hole shall be 0.060 m.

B.4.3.9 Flow Direction Changes

Changes in direction of flow through a maintenance hole greater than 90° will not be permitted.

In pipe sizes of 675 mm or greater, a change in direction of flow through a maintenance hole shall not be greater than 45°.

B.4.4 Catchbasins

B.4.4.1 Minimum Lead Size

Size of catchbasin leads shall be calculated by the engineer based on the catchment area and it will be the greater of the calculated size or:

- Double Catchbasin Lead: 300 mm
- Single Catchbasin Lead: 250 mm (In the **City of Guelph** the minimum is 200 mm)
- Minimum slope for catchbasin leads is 1.0%.

B.4.4.2 Catchbasin Lead Depth

The catchbasin lead obvert shall be a minimum of 1.2 m below the final road grade for new sewers and a desirable depth of 1.2 m for reconstruction projects.

Catchbasin leads do not require insulation.

B.4.4.3 Spacing

The maximum spacing between catchbasins or highpoint to first catchbasin shall be:

Road Type	Road Grade		
	< 3%	3% to 5%	>5%
For two (2) lane roads	90m	75m	60m

Road Type	Road Grade		
For four (4) lane roads	75m	60m	60m

The Engineer shall ensure that the catchbasin spacing and casting cover is adequate to collect the storm water.

B.4.4.4 Intersection Location

Catchbasins shall be located on the upstream side of all intersections where the road grade falls towards the intersection

B.4.4.5 Flow Direction Changes

Horizontal bends are to be avoided. Horizontal bends on catchbasin leads are not allowed unless permitted by the Contract Administrator.

B.4.4.6 Double Catchbasin

Double catchbasins are required at all low points, when water is collected from two directions. A single catchbasin may be considered if the total aggregate spacing to the adjacent catchbasins is less than the maximum spacing allowable, as noted above.

B.4.4.7 Side Inlet Catchbasin

Side inlet catchbasins shall be installed on Regional and other major arterial roads, or as directed by the Chief Municipal Engineer. If a side inlet catchbasin (including doubles and manholes) are not feasible to construct on a Regional Road a standard catchbasin (including doubles and manholes) will be fitted with OPSD frame & cover 400.11.

Side inlet catchbasins shall be installed on City of **Kitchener** and City of **Waterloo** roads when on-road bike facilities are proposed.

B.4.4.8 Double Catchbasin with Curb Inlet Overflow

Double catchbasin with curb inlet overflow shall be installed in the **City of Kitchener, City of Cambridge, Township of Woolwich** and the **Township of Wilmot** at all low points, when water is collected from two directions, unless the low point is at an intersection. A single catchbasin may be considered if the total aggregate spacing to the adjacent catchbasins is less than the maximum spacing allowable, as noted above. Please see drawing E4-07 and E4-08.

B.4.4.9 Sub-drains

When warranted by a geotechnical investigation, the minimum size is 150 mm. Sub-drain shall be connected to the downstream end of the sub-drain only.

Sub-drains are required 3.0 m on each side of low point catchbasins on **Regional** roads.

Township of Woolwich, Township of Wilmot, City of Waterloo and City of Kitchener requires continuous 150 mm dia. sub drain along curb on all projects.

B.4.4.10 Slotted Drain Pipe

Slotted drain pipe shall be utilized when:

- Road grade is equal to or larger than 5%
- Problem areas and where additional catchment is needed
- A slotted drain will not be used with a side inlet CB

B.4.4.11 Rear Yard Drainage

Rear yard catchbasins are to be provided with no sumps.

A catchbasin maintenance hole with a minimum 0.6m sump is required on the main line for the connection of a rear yard catchbasin lead, regardless of the lead size. Pipe size is to be designed based on drainage area and shall be included in the storm design sheets.

In the **City of Cambridge**, requirement for maintenance holes for rear yard catch basins will be subject to the approval of the City.

In the **City of Guelph**, maintenance holes are not required at the connection to rear yard catchbasins.

B.4.5 Services

B.4.5.1 Minimum Diameter

The minimum service size is 150 mm for storm services.

B.4.5.2 Location

Services shall be installed perpendicular to the main wherever practical.

Sewer connections for single and semi-detached dwellings shall be made with factory made fittings at locations to the Municipality's standard.

B.4.5.3 Slope

The minimum service slope is 2%

The maximum service slope is 8%

B.4.5.4 Flow Direction Changes

Horizontal bends are to be avoided.

B.4.5.5 Depth

The storm service obvert at property line shall be 1.2 m below the finished grade except in the **City of Guelph** where the depth shall be 2.5 m.

B.4.6 Geotechnical Report

A geotechnical report must be submitted to the Chief Municipal Engineer as part of the design of the storm sewer system unless otherwise waived by the Chief Municipal Engineer. Recommendations must be made regarding the storm sewer bedding, trench dewatering, and pipe selection. Where the geotechnical engineer has recommended filter cloth wrapping for clear stone bedding design drawings shall specify but not limited to locations, filter cloth material/product and details sections.

The geotechnical report shall also include test results and recommendations for the use and/or disposal of adversely impacted soils, such as from sodium and petroleum products, in accordance with current regulations.

B.4.7 Open Ditch and Culvert Design

Contact applicable Chief Municipal Engineer for design standards.

Region of Waterloo and Area Municipalities
Design Guidelines and Supplemental Specifications
For Municipal Services
Part C
Material Specifications

Material Specifications

Table of Contents

C.1	GENERAL	1
C.1.1	Ontario Provincial Standards.....	1
C.1.2	Definitions	1
C.1.3	Standards Council of Canada	1
C.1.4	Material Conformance.....	1
C.2	WATERMAIN	1
C.2.1	Approved Watermain Pipe material.....	1
C.2.1.1	Ductile Iron Pipe.....	3
C.2.1.1.2	Fittings	3
C.2.1.1.3	Joint Restraint	3
C.2.1.2	Concrete Pressure Pipe.....	3
C.2.1.3	Polyvinyl Chloride Pipe (PVC)	4
C.2.1.4	Polyvinyl Chloride Oriented (PVCO).....	5
C.2.1.5	High Density Polyethylene Pipe (HDPE)	5
C.2.2	Valves	6
C.2.2.1	Gate Valves	6
C.2.2.2	Combination Air and Vacuum Release Valves.....	7
C.2.3	Tapping Sleeves	7
C.2.4	Valve Chambers	7
C.2.4.1	Cast Iron Maintenance Hole Lids.....	7
C.2.4.2	Adjustment Units.....	7
C.2.4.3	Safety Post.....	8
C.2.5	Line Closure Couplings	8
C.2.6	Flange Adaptors	8
C.2.7	Valve Boxes	8
C.2.8	Hydrants.....	8
C.2.9	50 mm and Smaller Service Connections.....	9
C.2.9.1	Service Pipe.....	9

C.2.9.2	Service Saddles	10
C.2.9.3	PVC Tapped Couplings	10
C.2.9.4	Main Stops	10
C.2.9.5	Union Couplings.....	10
C.2.9.6	Curb Stops	10
C.2.9.7	Service Boxes	11
C.2.10	Temporary Watermains	11
C.2.11	Metal Items	11
C.2.12	Petrolatum Tape Systems	11
C.2.13	Anodes	12
C.2.14	Tracer Wire.....	12
C.2.15	Test Boxes	13
C.2.16	Warning Tape.....	13
C.3	SEWERS	13
C.3.1	Pipe Materials	13
C.3.1.1	Concrete Sewer Pipe and Fittings	13
C.3.1.2	PVC Sewer Pipe and Fittings	14
C.3.1.3	HDPE Sanitary Sewer Pipe and Fittings.....	14
C.3.1.4	HDPE Storm Sewer Pipe and Fittings	14
C.3.1.5	Approved Sanitary Sewer Pipe Materials	14
C.3.1.6	Sanitary Forcemain Material	15
C.3.1.7	Approved Storm Sewer Pipe Materials.....	16
C.3.2	Cast Iron Maintenance Hole Lids.....	17
C.3.3	Cast Iron Catchbasin Frames and Grates.....	17
C.3.4	Maintenance Hole and Catchbasin Adjustment Units	18
C.3.5	Slotted Pipe Drain	18
C.3.6	Flexible Couplings	18
C.3.7	Watertight Connectors.....	18

C.1 General

C.1.1 Ontario Provincial Standards

The Region of Waterloo and Area Municipal Design Guidelines and Supplemental Specifications for Municipal Services (DGSSMS) are supplemental to the Ontario Provincial Standards (OPS) and thus take precedence over the related specifications (OPSS's) and drawings (OPSD's).

C.1.2 Definitions

C.1.2.2 Approved equivalent: written approval by the Chief Municipal Engineer

C.1.3 Standards Council of Canada

All materials approved to CSA international standards shall be supplied from a plant approved by an organization accredited by the Standards Council of Canada.

C.1.4 Material Conformance

All materials shall be certified to the latest revised applicable specifications of the American Waterworks Association (AWWA), American Society for Testing and Materials (ASTM), National Sanitation Foundation (NSF) 14 & 61, American National Standard Institute (ANSI), Underwriters Laboratory (UL), American Association of State Highway and Transportation Officials (AASHTO) and the Canadian Standards Association (CSA). Certification to be provided to Municipality, as referenced in the following sections.

On a project specific basis, the Contractor may apply to have a product considered approved equivalent for any of the product categories listed in the following sections.

C.2 Watermain

C.2.1 Approved Watermain Pipe material

Type of Pipe	Specification	Diameter	Approved Use	Approved Manufacturer
Concrete Pressure Pipe	AWWA C301 & C303	Up to 525 mm	Mainline	Forterra, Concast, Coldstream, Decast, Hyprescon, M-Con, Rainbow
	AWWA C301	600 mm and larger	Mainline	
Ductile Iron	AWWA C151/A21.51 AWWA C150/A21.50 AWWA C111/A21.11	150 mm and larger	Mainline	Canada Pipe, Electrosteel Castings NuBlu

Type of Pipe	Specification	Diameter	Approved Use	Approved Manufacturer
HDPE	OPS 441 CSA B137.1	100mm to 600 mm	Mainline, Service Laterals	Pipe manufacturer must be approved by the Chief Municipal Engineer
DR 18 PVC	AWWA C900 CSA B137.3	100mm to 300mm	Mainline, Service Laterals	IPEX, NAPCO/North American Pipe (Royal), Diamond Plastics, Next Polymers Aqualoc, Northern Pipe Products, National Pipe & Plastic or approved equivalent
DR 25 PVC	AWWA C900 CSA B137.3	350mm up to 600mm	Mainline, Service Laterals	IPEX, NAPCO/North American Pipe (Royal), Diamond Plastics, Northern Pipe Product or approved equivalent
PVCO	AWWA 909 CSA B137.3.1 ANSI/NSF 61 Pressure Class 235 psi	150mm to 300mm	Mainline	IPEX or approved equivalent
PVCO	AWWA 909 CSA B137.3.1 ANSI/NSF 61 Pressure Class 156 psi	350mm to 450mm	Mainline	IPEX or approved equivalent

Notes:

- 1) The Region of Waterloo will not accept plastic pipe over 600mm diameter for watermain applications.
- 2) For any HDPE application the size and manufacturer must be approved by the Chief Municipal Engineer (C.2.1.5.1)
- 3) Prior to specifying pipe material, soils shall be assessed for contamination and for the presence of compounds that may negatively impact the suitability of the proposed materials. Nitrile gaskets or equivalent shall be specified for soils contaminated with hydrocarbons.

C.2.1.1 Ductile Iron Pipe

C.2.1.1.1 Manufacture

Ductile iron pipe shall be manufactured in accordance with AWWA C151/A21.51 and shall be cement lined in accordance with AWWA C104/A21.4. Ductile iron pipe shall be designed in accordance with AWWA C150/A21.50 and shall be minimum thickness as **pressure class 350**. Ductile iron pipe shall have bell and spigot rubber gasket joints manufactured in accordance with AWWA C111/A21.11. Copper bonding straps shall be supplied with bell and spigot joints to maintain electrical conductivity from pipe to pipe.

C.2.1.1.2 Fittings

Fittings shall be grey or ductile iron conforming to AWWA C110/A21.10 or compact ductile iron conforming to AWWA C153/A21.53. Fittings shall have mechanical joint ends conforming to AWWA C111/A21.11 unless otherwise specified and shall be cement lined in accordance with AWWA C104/A21.4. Cast iron fittings shall only be used for main sizes where compact ductile iron fittings are not available.

Copper bonding straps shall be used to maintain electrical conductivity.

Where flanged fittings are specified, gaskets shall be 3 mm thick full face rubber.

C.2.1.1.3 Joint Restraint

Joint restraints for ductile iron pipe shall be wedge action type meeting the requirements of AWWA C-111 where appropriate, and be listed by ULc or FM. Accepted products include EBAA(Series 1100), Romac (RomaGrip), Sigma (One Lok SLD, SLDH, SSLD), Star (Stargrip3000, 3100P, 3000OS), Clow MJ Field Lok, Clow (Tyler) Tufgrip (Series 1000, 2000) and UniFlange (Series 1400, 1450).

C.2.1.2 Concrete Pressure Pipe

C.2.1.2.1 Manufacture

Concrete pressure pipe shall be manufactured in accordance with AWWA standards C301 and C303 for pipe diameters up to 500 mm. Use AWWA C301 for pipe diameters 600 mm and larger.

C.2.1.2.2 Fittings

Fittings shall be manufactured in accordance to AWWA Standard C301 and C303.

C.2.1.2.3 Joints

Concrete pressure pipe and fittings shall be jointed using rubber gaskets, and approved joints as outlined in the manufacturer's installation guide and AWWA Standards C301 and C303. All joints shall be protected on the exterior using diapers and grout.

C.2.1.2.4 Thrust Restraint

Thrust restraint shall be provided through the use of restraining joints approved and supplied by the manufacturer.

C.2.1.3 Polyvinyl Chloride Pipe (PVC)

C.2.1.3.1 Manufacture

Polyvinyl chloride (PVC) pressure pipe shall be manufactured to cast iron outside diameters. PVC pipe shall be colour coded blue and shall have an integral wall-thickened bell designed for joint assembly using an elastomeric gasket conforming to ASTM D3139.

PVC pipe sizes 100 mm through 300 mm shall be minimum DR18, conform to AWWA C900 and be certified to CSA B137.3. PVC pipe in sizes 350 mm and larger shall be minimum DR25, conform to AWWA C900 and be certified to CSA B137.3.

Maximum size of PVC watermain shall be 600 mm diameter in the Region of Waterloo.

C.2.1.3.2 Fittings

Non-Metallic

Non-metallic Fittings for 100mm up to 300mmPVC pipe shall be injection moulded with push on gasket joints, conform to AWWA C-907 and shall be certified to CSA B137.2.

Fittings 350 mm to 600 mm shall be one piece construction or manufactured from segments of AWWA C900 PVC pipe bonded together and over-wrapped with fibreglass reinforced polyester to meet the requirements of the standard. The pressure ratings of the fabricated fittings shall match the pressure ratings of the pipe.

Metallic

Fittings shall be grey or ductile iron conforming to AWWA C110/A21.10 or compact ductile iron conforming to AWWA C153/A21.53. Fittings shall have mechanical joint ends conforming to AWWA C111/A21.11 unless otherwise specified and shall be cement lined in accordance with AWWA C104/A21.4. Cast iron fittings shall only be used for main sizes where compact ductile iron fittings are not available.

RCT Flex Tite fittings are also permitted, except in the **City of Kitchener**.

C.2.1.3.3 Joint Restraints

Serrated (machined) ring type joint restraints for PVC pipe shall meet the requirements of Uni-Bell B-13 or ASTM F1674, and AWWA C-111 where appropriate, and be listed by ULc or FM. Accepted products include Clow (Series 300, 350, 360), EBAA (Series 1600, 2500, 2800), Sigma (PV Lok PWP, PWM,PWPF), Star (Stargrip 1000, 1100, 1200, 1000G2, 1100G2, 1200G2), Smith-Blair (Cam-Lock 111,120 pipe ends Bell Lock 115, 135, 153 for pipe bells, hydrants, valves and fittings, Pipe Lock 471, 472, 473, 474 for PVC and ductile iron connection, Flange Lock 911, 920, 923, 973 flanged to plain end pipe), Tufgrip (Tyler) (Series 1000, 2000)

Wedge action type joint restraints for PVC pipe shall meet the requirements of Uni-Bell B-13 or ASTM F1674, and AWWA C-111 where appropriate, and be listed by ULc or FM. Accepted products include EBAA (Series 2000PV Mega Lug), Sigma (One Lok SLC), Star (Stargrip 4000,4100P, 4000G2, ALL Stargrip Series 4300) and UniFlange (Series 1500).

C.2.1.4 Polyvinyl Chloride Oriented (PVCO)**C.2.1.4.1 Manufacture**

Molecularly oriented PVC pipe in sizes 150 mm (6") through 450 mm (18") shall be Biaxially Oriented (molecular orientation in two directions), third party certified to AWWA C900 and third party certified to NSF 61 for potable water use. The pipe shall have Cast Iron Outside Diameters (CIOD). Be colour coded blue and have a Pressure Class of 235 psi for 100mm (10') through 300mm (12') and minimum Pressure Class of 165 psi for sizes 350 (14') mm through 450mm (18').

C.2.1.4.2 Fittings**Non-Metallic**

Non-metallic Fittings for 100mm up to 300mm PVC pipe shall be injection moulded with push on gasket joints, conform to AWWA C-907 and shall be certified to CSA B137.2.

Fittings 350 mm to 600 mm shall be one piece construction or manufactured from segments of AWWA C900 PVC pipe bonded together and over-wrapped with fibreglass reinforced polyester to meet the requirements of the standard. The pressure ratings of the fabricated fittings shall match the pressure ratings of the pipe.

Metallic

Fittings shall be grey or ductile iron conforming to AWWA C110/A21.10 or compact ductile iron conforming to AWWA C153/A21.53. Fittings shall have mechanical joint ends conforming to AWWA C111/A21.11 unless otherwise specified and shall be cement lined in accordance with AWWA C104/A21.4. Cast iron fittings shall only be used for main sizes where compact ductile iron fittings are not available.

RCT Flex Tite fittings are also permitted, except in the City of Kitchener.

C.2.1.4.3 Joint Restraints

Serrated (machined) ring type joint restraints for PVCO pipe shall meet the requirements of Uni-Bell B-13 or ASTM F1674, and AWWA C-111 where appropriate, and be listed by ULc or FM. Accepted products include Clow (Series 300, 350, 360), EBAA (Series 1600, 2500, 2800), Sigma (PV Lok PWP, PWM, PWPF), Star (Stargrip 1000, 1100, 1200 1000G2, 1100G2, 1200G2), Smith-Blair (Cam-Lock 111, 120 pipe ends Bell Lock 115, 135, 153 for pipe bells, hydrants, valves and fittings, Pipe Lock 471, 472, 473, 474 for PVC and ductile iron connection, Flange Lock 911, 920, 923, 973 flanged to plain end pipe), Tufgrip (Tyler) (Series 1000, 2000)

Wedge action type joint restraints for PVC pipe shall meet the requirements of Uni-Bell B-13 or ASTM F1674, and AWWA C-111 where appropriate, and be listed by ULc or FM. Accepted products include EBAA (Series 2000PV), Sigma (One Lok SLC), Star (Stargrip 4000, 4100P. ALL Star Series 4300) and UniFlange (Series 1300, 1360 and 1390).

C.2.1.5 High Density Polyethylene Pipe (HDPE)**C.2.1.5.1 Manufacture**

Where high density polyethylene (HDPE) pressure pipe is specified and approved by the Chief Municipal Engineer for situations of specialized installation, it shall be ductile iron pipe outside diameter, co-extruded blue or blue stripe in colour, and meet the requirements of OPS 441 and CSA 137.1.

With the use of HDPE pipe post certification is required by the installer and manufacturer to ensure compliance with the manufacturer specifications for the transition connection. Post certification will require a professional engineers stamp.

C.2.1.5.2 Fittings

HDPE pipe fittings shall meet the requirements of OPS 441.

C.2.1.5.3 Joint Restraints

Joints will be restrained in accordance with OPS 441.

C.2.2 Valves

C.2.2.1 Gate Valves

Gate valves equal to and less than 300 mm shall be resilient wedge. Gate valves greater than 300 mm can be either resilient wedge or double disk. Non-rotational / anti-rotational T-bolt kits are to be used on ALL gate valves.

Resilient Wedge Valves

Resilient wedge valves shall conform to AWWA C509 or C515.

Resilient wedge valves shall be Mueller, Clow, EJ or AVK.

In the **City of Guelph** only Clow, EJ and Mueller are allowed.

Gate valves in sizes 100 mm to 350 mm shall have mechanical joint ends.

All gate valves shall be iron body, bronze mounted with inside screw, non-rising spindle and a 50 mm operating nut that opens by turning counter-clockwise. All gate valves shall be epoxy coated.

Gate valves in sizes 350 mm and larger shall have a minimum 50 mm integral bypass, mechanical joint or flanged ends, waterproof spur gearing and shall be supplied with a shop drawing. The integral bypass must be manufactured as part of the cast body. The integral bypass shall be fabricated with a sufficient offset from the gate valve ensuring that any part of the valve and/or bonnet will not obstruct the operation of the bypass valve.

In the **City of Cambridge** resilient seat gate valves that include a bypass or spur gearing will not be allowed.

Double Disk Valves

Double disk valves shall conform to AWWA C500.

Double disk valves shall be Clow or Mueller.

All gate valves shall be iron body, bronze mounted with inside screw, non-rising spindle and a 50 mm operating nut that opens by turning counter-clockwise. All gate valves shall be epoxy coated.

Double Disk valves shall have mechanical joint ends.

For 400 mm gate valves no spur gearing is required and shall conform to AWWA C515 Ductile Iron. Gate valves in sizes 450 mm and larger shall have an integral bypass, mechanical joint or flanged ends, waterproof spur gearing and shall be supplied with a shop drawing. The integral bypass shall be fabricated with a sufficient offset from the gate valve ensuring that any part of the valve and/or bonnet will not obstruct the operation of the bypass valve.

AVK Tapping valves are not permitted in the **City of Kitchener**.

C.2.2.2 Combination Air and Vacuum Release Valves

Combination air and vacuum release valves shall consist of an air and vacuum valve and an air release valve in single body housing. The body and cover shall be cast iron conforming to ASTM A126 Class B and fusion bonded epoxy coating to meet or exceed C-213. In addition NSF 61 certification is required. Combination air and vacuum release valves shall be Golden Anderson Industries (Figure GA945) or ARI D-040 series 1" and 2, D-090 direct bury air valve. The D-040C epoxy cast series shall be used if chambers are required.

- H-TEC Model 992-00 Air Valve Set NSF/ANSI-61 & 372 AWWA C512 Stainless Steel Shell for Municipal Water Distribution Pipe.

C.2.3 Tapping Sleeves

Carbon steel tapping sleeves shall be Smith-Blair 622, Mueller H-615, Ford FTSC. Carbon steel tapping sleeves shall have fusion bonded epoxy finish and come equipped with TYPE 304 stainless steel bolts, nuts and washers. In the City of Kitchener, only carbon steel tapping sleeves shall be used.

Stainless steel tapping sleeves shall be Ford FAST, Smith-Blair 663, Mueller H304. Stainless steel tapping sleeves including flanges shall be manufactured from Type 304 stainless steel and shall come equipped with Type 304 stainless steel bolts, nuts and washers.

C.2.4 Valve Chambers

C.2.4.1 Cast Iron Maintenance Hole Lids

Cast iron maintenance hole lids shall be as per OPSS 1850 and OPSD 401.010 Type A as manufactured by Bibby, East Jordan and Cedar Infrastructure Products Inc.

C.2.4.2 Adjustment Units

Concrete adjustment units shall be as per OPSS 407 and OPSD 704.01. Precast adjustment units shall be laid in a full bed of mortar with successive units being joined using sealant as recommended by the manufacturer. A minimum of one (1) adjustment unit shall be installed with a minimum height of 75 mm. A maximum of three adjustment units may be installed to a total height not in excess of 300 mm.

Concrete brick and mortar shall not be used.

Rubber adjustment units as per OPSS 1853 or HDPE as per OPSS 1854, as manufactured by IPEX under the trade name "Lifesaver".

City of Cambridge, City of Guelph, Township of Wilmot does not permit plastic adjustment units.

C.2.4.3 Safety Post

Safety posts shall be galvanized "Ladder Up" as manufactured by "BILCO", MSU Model 3100.

C.2.5 Line Closure Couplings

Line closure coupling shall be Robar Style 1408 (Robar is not accepted in **Kitchener**), Smith-Blair Style 411, 421, Mueller Viking Johnson Maxifit, Hymax 2000. Line closure coupling will not be allowed in **City of Guelph** only MJ solid sleeve.

C.2.6 Flange Adaptors

Flange adaptors shall be Uni-Flange Series 400 or 900, Clow Series 40 and 90, EBAA Iron Megaflange Series 2100, Smith-Blair I Series 913.

C.2.7 Valve Boxes

Cast iron valve boxes shall be a screw type box with a No. 6 Base as supplied by Bibby, Mueller, Star, or Domcast. The valve box must be raised to final grade. Road levellers (inside screw type) of any style shall not be installed.

C.2.8 Hydrants

Hydrants shall conform to AWWA C502 for Dry Barrel Hydrants and shall open counter clockwise (**clockwise in the City of Guelph**) by a 32 mm square operating nut. Hydrants shall have tapped drain ports, 150 mm mechanical joint inlet with brass to brass fittings on the main valve seat, two 63.5 mm (2.5 in) hose nozzles spread 180 degrees apart and a 114.3 mm (4.5 in) pumper nozzle with a 100 mm ULC approved Stortz connection. Hydrants shall be connected to the main using 150 mm lead, 150 gate valve, and anchor tee. Hydrants shall be supplied for a minimum 2.3 m depth of trench. A maximum of one hydrant extension (300 mm or less for new development) shall be allowed except **in City of Guelph**, with authorization of the Chief Municipal Engineer, between the upper and lower hydrant barrels for deeper installations.

Hydrant barrels shall be painted chrome yellow with a high gloss exterior paint over a quick dry oxide primer. Stortz nozzles shall be painted black. The colour(s) of hydrant bonnet and nozzle caps shall be obtained from the Chief Municipal Engineer and painted with a high gloss exterior paint over a quick dry oxide primer. Fire hydrant nozzles shall be greased by manufacturer before coming to site.

All private hydrants must be painted red.

In the **City of Kitchener, Township of Wilmot, Township of Woolwich** (including Regional projects), and the **City of Guelph** the watermain diameter in inches to which the hydrant is connected shall be painted in black letters 200 mm high on the face of the hydrant barrel immediately below the pumper nozzle.

Hydrants shall be Mueller Canada (Century or Modern Centurian), Clow (Brigadier) or AVK (Nostalgic dry barrel). (**City of Cambridge** permits EJ Watermaster hydrants).

Township of Woolwich owned hydrants shall be Mueller Canada (Century) or Clow Brigadier hydrants.

City of Guelph owned hydrants shall be McAvity style M-67 or EJ 5CD250 HYD MJ-2AD WTRMSTR STZ or Mueller Canada (Century).

City of Waterloo owned hydrants shall be McAvity style M67 – M93 or Mueller Canada (Century - Darling).

Township of Wilmot owned hydrants shall be Mueller Canada (Century or Modern Centurian) or Clow (Brigadier)

For watermains installed greater than 2 m depth within the **City of Kitchener**, Mueller Canada Valve (Century) hydrants, Clow Brigadier in-line or AVK (Nostalgic dry barrel) hydrants must be installed.

For watermains installed greater than 2 m depth within the **Township of Wilmot**, Mueller Canada (Century) hydrants or Clow Brigadier in-line hydrants must be installed.

C.2.9 50 mm and Smaller Service Connections

C.2.9.1 Service Pipe

Copper service pipe for services 25 mm and 50 mm shall be Type “K” soft copper and shall conform to ASTM B88.

Polyethylene service pipe for services 25 mm and 50 mm shall be certified to CSA B137.1 minimum Series 160, stiffeners shall be used.

AquaPure PE-RT municipal water service tubing for services 25 mm and 50 mm certified to AWWA C901, CSA B137.18 and NSF 14 and 61. Pressure rated to 200 psi at 73 Fahrenheit. Stiffeners shall be used.

Composite pipe for services 25 mm in diameter shall be certified to CSA B137.9 and shall be as manufactured by IPEX under the trade name “Q-Line”.

Blue 904-PEX and Muncipex municipal water service tubing for services 25mm and 50 mm shall be certified to AWWA C904, CSA B137.5 and NSF 14 and 61. (**City of Cambridge only accepts Blue 904-PEX, Muncipex and AquaPure PE-RT for water services**).

All service pipes shall be of new material. Kinked, crushed or distorted tubing will not be accepted.

All service piping in the **City of Guelph** shall be copper.

C.2.9.2 Service Saddles

Saddles shall be 18 gauge Type 304 stainless steel with AWWA tapered thread. Saddles for PVC pipe shall be double bolted. Saddles shall have a minimum of 50 mm bearing width and shall be fully contoured to the outside of the pipe.

For PVC pipe, service saddles shall be Cambridge Brass (Teck) Series 8405 and saddle with integral corporation stop Series 8415, Ford FS303, Romac, Smith-Blair Series 375 and 373 and come equipped with TYPE 304 stainless steel bolts, nuts and washers.

For metallic pipe, service saddles shall be Smith Blair 313 Epoxy coated and come equipped with TYPE 304 stainless steel bolts, nuts and washers.

City of Cambridge and Township of Wilmot no longer permits the use of service saddles for service connections 50 mm or larger.

C.2.9.3 PVC Tapped Couplings

Tapped couplings are approved for use on PVC watermains and are to be used exclusively in the **City of Guelph**.

C.2.9.4 Main Stops

Main stops shall be ball type with the same size as the service pipe and shall have AWWA tapered thread inlet and compression joint outlet. Main stops shall be equipped with electrical grounding tail nuts for connection of tracer wire and anodes for corrosion protection of non-metallic watermain, all of which are to be protected using a petrolatum tape system.

Main stops shall conform to AWWA C800 and be Cambridge Brass series, Ford series or Mueller. Any grease used will be NSF, even if it is on non-wetted surfaces.

C.2.9.5 Union Couplings

Union couplings shall have compression joints and shall be Cambridge Brass Series 118, Mueller 15400 Series, Ford Pack Joint C44 or Straub Tabco Inc.

C.2.9.6 Curb Stops

Curb stops shall be the same size as the service pipe and shall be compression joint (CJ) inlet and (CJ) outlet.

Curb stops shall be equipped with electrical grounding tail nuts for connection of tracer wire and anodes for corrosion protection of non-metallic watermain, all of which are to be protected using a petrolatum tape system.

Curb stops shall be Cambridge Brass 202 Series, Mueller B-25209 Series or Ford B44 Series.

In the **City of Kitchener**, curb stops shall be Cambridge Brass 202 Series, Mueller H-15209 Series or Ford B44 Series.

Stop and drain type curb stops are not accepted unless special approval is obtained by the Chief Municipal Engineer.

C.2.9.7 Service Boxes

Service boxes shall be cast iron with a 25 mm upper section and shall have stainless steel rods and cotter pins. Service boxes shall be adjustable to between 1.8 metres and 2.1 metres to suit service depths.

Service boxes shall be Mueller A-314 or A-726, Star Pipe Products #9D1 or #9D2, Domcast D1 and Cedar Infrastructure. For other sizes refer to the municipality.

C.2.10 Temporary Watermains

All temporary distribution and service piping shall be certified for potable water use as per ANSI/NSF Standard 14 and Standard 61. No galvanized material will be allowed.

The distribution piping shall be a minimum 50 mm diameter, Aqua Mine or Certa-Lok high impact, ASTM PVC 1120, D2241, SDR17, 1720 kPa. Larger diameter may be required for fire protection.

Service piping shall be minimum 19 mm diameter Kuritec.

C.2.11 Metal Items**C.2.11.1 Bolts, Nuts and Washers****C.2.11.1.1 Cor-Ten**

Cor-Ten T-head bolts, nuts and washers shall conform to the latest issue of ASTM and AWWA.

C.2.11.1.2 Cadmium Coated

Cadmium coated bolts, nuts and washers shall conform to the latest issue of ASTM. Use Grade 2, Designated A 305 bolts for flanges up to and including 300 mm diameter and Grade 5, Designated A 307 for flanges larger than 300 mm diameter.

C.2.11.1.3 Stainless Steel

Stainless steel bolts, nuts and washers shall be stainless steel Type 304 conforming to the latest issue of ASTM F593 and F594.

C.2.11.1.4 Cast Iron

Cast Iron shall conform to ASTM Designation A-48, Class 30B, Standard Specifications for Grey Iron Castings. Cast iron products shall be asphalt coated.

C.2.11.1.5 Galvanizing

Galvanizing shall conform to the standard specifications for ASTM Designation A.123 - Zinc Coatings on Structural Steel Shapes. Metal products specified as galvanized shall be galvanized after fabrication.

C.2.12 Petrolatum Tape Systems

Petrolatum tape systems shall be comprised of three components; paste, mastic, tape and meet the requirements of AWWA C217-09.

Anti-corrosion wrap shall be as supplied by Denso North America Inc. or Petro Coating Systems Ltd. or Rustrol Systems (Interprovincial Corrosion Control Company Ltd) or Advanced Corrosion Solutions Inc. Only material from suppliers listed shall be used on an installation. At no time shall materials from either system be utilized with the other.

Denso coating material shall consist of Denso paste or Denso priming Solution (for cold temperature application), Denso Profiling Mastic or Denso Mastic Blanket, and Denso LT Tape.

PP Series Primer Paste, PM Series Mastic, LT/ST/Ht Petroleum Tape, PVC 250 Overwrap Tape from Petro Coating Systems Ltd.

Rustrol Systems materials shall consist of PetroWrap Primer, PetroWrap Mastic and PetroWrap Tape

Advanced Corrosion Solutions shall consist of PetroGuard primer paste, mastic, tape and overwrap (adhesive PVC)

C.2.13 Anodes

Packaged anodes shall be zinc Z-24-48 (24lb) manufactured using a high purity zinc (99.99% pure zinc) conforming to ASTM B-418 Type II. The anode shall have an average current efficiency of 90% and provide an open circuit potential with a minimum 1.10 Volt D.C. as measured with respect to copper / copper sulphate reference electrode. The zinc casting shall have a minimum 3.2 mm (0.125") diameter galvanized steel core wire throughout its length and shall be packaged in a cardboard or cloth container approximately 100 mm in diameter. The depolarising material surrounding the zinc casting shall be composed of a gypsum/bentonite base material having an electrical resistivity less than 50 ohm/cm wet. An insulated copper wire (AWG #10/7 strand), 2m minimum in length shall be brazed to the end of the core wire.

C.2.14 Tracer Wire

Tracer wire shall be #8 gauge TWU multi-strand copper.

Splices and other wire to wire connections shall be made by using a Dryconn® VisiLock® with SmartGel® splice Box (#98010) (or approved equivalent) wrapped copper split bolt or a Dryconn® King 9 Dark Blue (#10990) waterproof connector (or approved equivalent) as shown on Drawing E2-15.

A maximum of 200 m spacing, or as shown on design drawings, must be provided with Regional test ports. Also, test ports are to be installed at each end of trunk watermain.

For horizontal directional drilling applications or pipe bursting applications, the strength (gauge) of the tracer wire as well as the number of tracer wires required shall be confirmed by the Engineer.

Within the **City of Waterloo**, tracer wire for open trench construction shall be blue in colour (B), High Strength (HS) 12 gauge (AWG) Copper Clad Steel (CCS) wire. Wire shall have a

minimal break load of 452 lbs, a 30 mil HDPE jacket and rated for direct bury application. Wire shall be Copperhead 1230-BHS or approved equivalent. Tracer wire for trenchless construction shall be blue in colour (B), Extra High Strength (EHS) 12 gauge (AWG) Copper Clad Steel (CCS) wire. Wire shall have a minimal break load of 1150 lbs, a 45 mil HDPE jacket and shall be rated for directional drill application. Wire shall be Copperhead 1245-BEHS or approved equivalent.

Within the **City of Waterloo** all wire to wire connectors shall be filled with a waterproof dielectric silicone and rated for direct bury application. New connections (12 gauge AWG CCS wire) or connection to existing tracer wire (8-14 gauge AWG wire) shall use DryConn 3-way direct bury lug style connectors (Copperhead Model 3WB-01) or approved equivalent. Connections for 1245-BEHS wire shall use the appropriate pipe burst connector; In-line splice connections to be made with Copperhead Model SC-PB-01 or approved equivalent. Three-way connections to be made with Copperhead Model SC-3WPB or approved equivalent.

C.2.15 Test Boxes

The **City of Waterloo** requires tracer wire test boxes to be installed at hydrants and 100mm dia. and larger services.

Test boxes in a landscaped area shall be Copperhead SnakePit Model LD14-TP, 350 mm in length with a cast iron blue locking lid with “water” cast into the cap or approved equivalent.

Test boxes in a hardscaped area shall be Copperhead SnakePit Model CD14-TP, 350 mm in length with a cast iron blue locking lid with “water” cast into the cap or approved equivalent.

Refer to the **City of Waterloo** Tracer Wire Specification located on the City of Waterloo’s website for standards and guidelines for test box installations.

C.2.16 Warning Tape

Warning tape for identification of non-potable water mains shall be 3.5 mil polyethylene underground warning tape, 75 mm wide, white letters on blue background as supplied by Seton Canada or approved equal.

For raw water mains, wording shall be “RAW water line” and the warning tape shall be supplied by the Region for mains within the Region of Waterloo.

C.3 Sewers

C.3.1 Pipe Materials

Pipe materials for storm and sanitary sewer mainline, fittings and service laterals shall be certified by CSA international or accredited by the Standard Council of Canada (SCC).

Prior to specifying pipe material, soils shall be assessed for contamination and for the presence of compounds that may negatively impact the suitability of the proposed materials. Nitrile gaskets or equivalent shall be specified for soils contaminated with hydrocarbons.

C.3.1.1 Concrete Sewer Pipe and Fittings

Circular concrete pipe and fittings shall conform to OPSS 1820 and shall be manufactured at a plant certified under the Canadian Precast Concrete Quality Assurance (CPCQA) Certification Program. Non reinforced concrete pipe shall be according to CSA A257.1. Reinforced concrete pipe shall be according to CSA A257.2. Precast reinforced concrete manhole shall be according the CSA A257.4. Joints and gaskets shall be according to CSA A257.3.

C.3.1.2 PVC Sewer Pipe and Fittings

Circular PVC pipe and fittings complete with bell and spigot joints, rubber gasket, lubricant and all other necessary appurtenances shall be manufactured in conformance with OPSS 1841 and shall be certified to CSA B182.2 for PVC Sewer Pipe and Fittings or CSA B182.4 for Profile PVC Sewer Pipe and Fittings. PVC pipe shall have a minimum pipe stiffness of 320 kPa.

C.3.1.3 HDPE Sanitary Sewer Pipe and Fittings

Circular PE pipe and fittings complete with bell and spigot joints, rubber gasket, lubricant and all other necessary appurtenances shall be manufactured in accordance with OPSS 1840 using virgin resin and shall be certified to CSA B182.6 for Profile Polyethylene Sewer Pipe and Fittings. Circular PE pipe and fittings shall have a minimum pipe stiffness of 320 kPa and 100 kPa gasket joints.

The transition / connection from HDPE pipe to PVC, PVCO, ductile, cast iron, etc. shall be designed by the Engineer. The engineer shall take into account the following but not limited to: performance of the different materials, American Standard of Testing and Material specification (ASTM), Plastic Pipe Institute handbook of Polyethylene pipe, OPSS / OPSD, manufacture specifications.

C.3.1.4 HDPE Storm Sewer Pipe and Fittings

Circular profile PE pipe shall be complete with bell and spigot joints, rubber gasket, lubricant and all other necessary appurtenances and shall meet the requirements of OPSS 1840 (latest revision) and be manufactured in accordance with CSA B182.8 Profile Polyethylene Storm Sewer and Drainage Pipe and Fittings (latest revision) using virgin resin and shall be certified to this standard by a product certification body accredited by the Standards Council of Canada (SCC). Circular profile PE pipe shall have a minimum pipe stiffness of 320 kPa and 74 kPa water tight gasket joints (Type 1). All fittings used for PE installation shall be PVC quality and certified to either CSA B182.2 for PVC Sewer Pipe and Fittings or CSA B182.4 for Profile PVC Sewer Pipe and Fittings. PVC pipe shall have a minimum pipe stiffness of 320 kPa.

C.3.1.5 Approved Sanitary Sewer Pipe Materials

Type of Pipe	Specification	Diameter	Approved Use	Approved Manufacturer
Non-Reinforced Concrete	CSA A257.1 Extra Strength	200 mm to 250 mm	mainline	Forterra,

Type of Pipe	Specification	Diameter	Approved Use	Approved Manufacturer
Reinforced Concrete	CSA A257.2	300 mm and larger	mainline	Forterra, Concast, Coldstream, Decast, M-Con, Rainbow, Co-Pipe Product (To be confirmed)
SDR 35 PVC	CSA B182.2, 320 kPa Stiffness	200 mm and larger	mainline	IPEX, Next Polymers, NAPCO/North American Pipe (Royal), Diamond Plastics, Northern Pipe Products, National Pipe & Plastics
SDR 35 PVC	CSA B182.2, 320 kPa Stiffness	200 mm and larger	mainline	IPEX (Enviro-Tite)
SDR 28 PVC	CSA B182.2, 625 kPa Stiffness	100 mm and 150 mm	service laterals	IPEX, Next Polymers, NAPCO/North American Pipe (Royal), Diamond Plastics, Northern Pipe Products, National Pipe & Plastics
DR 17 HDPE	C901	100 mm and 150 mm	Trenchless service laterals with internal fusion beads removed	Approved by Design Engineer
Profile Polyethylene	CSA B182.6 320 kPa Stiffness	100 mm and 150 mm	service laterals (requires approval from Chief Municipal Engineer)	Armtec (Polytite)

C.3.1.6 Sanitary Forcemain Material

Sanitary forcemain material shall be selected to suit the installation and system requirements and be pre-approved by the municipality. Under no circumstances shall the material selected for the forcemain be colour coded blue.

C.3.1.7 Approved Storm Sewer Pipe Materials

Type of Pipe	Specification	Diameter	Approved Use	Approved Manufacturer
Concrete	CSA A257.1 Extra Strength	250 mm to 300 mm	Catchbasin lead and service connections	Forterra
		200 mm to 300 mm	Service connections	Forterra
Concrete	CSA A257.2 Reinforced	300 mm and larger	Mainline and service connections	Forterra, Concast, Coldstream, Decast, M-Con, Rainbow, Co- Pipe
SDR 35 PVC	CSA B182.2 – 320 kPa Stiffness	200 mm and larger	Mainline, catchbasin lead and service connections	IPEX, Next Polymers, NAPCO/North American Pipe (Royal), Diamond Plastics, Northern Pipe Products, National Pipe & Plastics
SDR 28 PVC	CSA B182.2 - 625 kPa Stiffness	150 mm	Service connections	IPEX, Next Polymers, NAPCO/North American Pipe (Royal), Diamond Plastics, Northern Pipe Products, National Pipe & Plastics
SDR 28 PVC	CSA B182.2 - 625 kPa Stiffness	150 mm	Service connections	IPEX (Enviro-Tite)
Profile HDPE	CSA 182.8 – 320 kPa stiffness watertight gasket min 75 kPa, PVC fittings to be used	300 mm min. Sizes vary as per municipality (See Note below)	Mainline	ADS Canada (not approved in the City of Guelph), Soleno

Type of Pipe	Specification	Diameter	Approved Use	Approved Manufacturer
Profile PVC 1	CSA B182.4 – 320 kPa Stiffness	200 mm and larger	Service connections	IPEX, Next Polymers, NAPCO/North American Pipe (Royal)
		250 mm and larger	Mainline and catchbasin lead	IPEX, Next Polymers, NAPCO/North American Pipe (Royal)
Profile HDPE	CSA B182.6 320 kPa Stiffness	200 mm and larger	Service connections	Armtec (Polytite) ADS Canada
		250 mm and larger	mainline and catchbasin lead	Armtec (Polytite) ADS Canada
Profile Polypropylene	CSA B182.13 320 kPa Stiffness	300 to 600 mm	mainline and catchbasin lead	ADS Canada

The **Region of Waterloo, Township of North Dumfries, the City of Kitchener, the City of Cambridge, and City of Guelph** will **not** accept flexible pipe over 600mm diameter. The City of Waterloo will not accept flexible pipe over 525 mm. **The Township of Wilmot will not** accept flexible pipe over 375 mm diameter. **Township of Woolwich will not** accept flexible pipe over 450 mm diameter.

The **City of Kitchener, City of Waterloo, City of Guelph, the Township of Wilmot, and Township of Woolwich** do **not** accept Profile PVC pipe (CSA 182.4).

C.3.2 Cast Iron Maintenance Hole Lids

Cast iron maintenance hole lids shall be as per OPSS 1850 and OPSD 401.010 Type “A” Closed Cover as manufactured by Bibby, Cedar Infrastructure, East Jordan (including East Jordan Optimized), Domcast or Star Pipe Canada. In the **City of Kitchener** Type “B” Cover is to be used for storm sewer applications.

All new maintenance holes shall be fitted with self levelling manhole frame and cover from EJ (Product No. 8” guide frame 00302202 and 4” guide frame 00302212A01), Bibby-Ste-Croix (Auto Stable C-50M-ONT), Star Pipe Products MH24SL, Domcast or Cedar Infrastructure Products D2333 on **Region of Waterloo, City of Cambridge, City of Kitchener, City of Waterloo, and Township of Woolwich** roadways. All self-level frame and covers to be supplied with rubber gaskets with the exception of Bibby-Ste-Croix (Auto Stable C-50M-ONT).

C.3.3 Cast Iron Catchbasin Frames and Grates

Cast iron catchbasin frames and grates shall conform to OPSS 1850 and shall be manufactured by Bibby, East Jordan (including East Jordan Optimized), Domcast, Star, or Cedar Infrastructure Products Inc. Catchbasin frames and grates shall be as per:

- SSMS E4-03 and E4-041 and E4-042 on all **Region of Waterloo** owned roadways; **City of Kitchener** and **City of Waterloo** with on-road bike lanes; or as directed by the Municipality
- OPSD 400.10 on the **City of Cambridge** and **Waterloo** roadways
- OPSD 400.11 on the **City of Kitchener** (unless there are on-road bike lanes) and **Township of Woolwich** roadways
- SSMS E4-01 on the **Township of Wilmot** roadways
- OPSD 400.010 on the **City of Guelph** roadways

C.3.4 Maintenance Hole and Catchbasin Adjustment Units

Refer to section D.3.3.2 for adjustment unit installation.

Concrete brick and mortar shall not be used.

The use of rubber adjustment units as per OPSS 1853 or HDPE OPSS 1854, as manufactured by IPEX under the trade name “Lifesaver” is acceptable.

C.3.5 Slotted Pipe Drain

Slotted drain pipe shall be fabricated from galvanized steel in accordance with AASHTO M-36 and shall have a minimum wall thickness of 1.6 mm. Slotted drain pipe shall be as manufactured by Armtec.

C.3.6 Flexible Couplings

Flexible couplings shall be as supplied by Fernco, Mission or Preper.

C.3.7 Watertight Connectors

Watertight connectors shall be resilient connectors and applied to flexible pipe for sanitary and storm sewers. Concrete sanitary sewers shall have resilient connectors.

All pipe to maintenance hole shall meet and or exceed ASTM C 923, Standard Specification for Resilient Connectors Between Reinforced Concrete Manholes, Structures, Pipes and Laterals. All mechanical devices if employed, including castings, bolt assemblies shall use non-magnetic 300 series stainless steel with no welds or rivets in the sleeve or bolt assembly. Take up clamps shall use non-magnetic 304 series stainless steel. Plastic parts or components aren't allowed. Connector sizes 700 mm (28”) and above shall employ multiple adjusters to better equalize the rubber and provide a uniform seal. The installation of the connector shall be accomplished at initial install and shall require no additional adjustments or installation at a

later time to provide a watertight seal. Catchbasins shall not have factory installed boots but shall have a grout adapter fitting.

Grout Adapters shall be used on flexible pipe when the use of a resilient connector is not possible.

**Region of Waterloo and Area Municipalities
Design Guidelines and Supplemental Specifications
For Municipal Services
Part D
Construction Specifications**

Construction Specifications

Table of Contents

D.1	General	1
D.1.1	Ontario Provincial Standards	1
D.1.2	Special Conditions or Special Provisions	1
D.1.3	Definitions	1
D.1.4	Environment	1
D.1.4.1	Blasting	1
D.1.4.2	Smog Alert.....	1
D.1.4.3	Discharge to Sewers	2
D.1.5	Traffic Control	2
D.1.6	Safety Requirements	2
D.1.7	Materials	2
D.1.8	Layout	2
D.1.9	Pre-Condition Survey	2
D.1.10	Site Preparation	2
D.1.10.1	Clearing and Grubbing	2
D.1.10.2	Removals	2
D.1.10.3	Demolition	3
D.1.11	Excavation	3
D.1.11.1	Temporary Stockpiling of Material	3
D.1.11.2	Surplus Excavated Material	3
D.1.11.3	Width of Trenches	3
D.1.11.4	Open Trenching	3
D.1.11.5	Trenchless Installations	4
D.1.12	Backfilling and Compaction	4
D.1.12.1	Bedding.....	4
D.1.12.2	Backfill Material.....	4
D.1.12.3	Imported Backfill	4
D.1.12.4	Backfill under Utilities	4
D.2	WATERMAINS	5
D.2.1	Ontario Provincial Standard Specifications	5

D.2.2	Project Coordination	5
D.2.2.1	Notification of Operating Authority	5
D.2.2.2	Notification of Local Water Users	5
D.2.2.3	Shutting Down or Charging Mains	6
D.2.2.4	Water Interruption	6
D.2.2.5	Requirements Outside of Contract Limits	6
D.2.3	Temporary Water Distribution System.....	6
D.2.3.1	General	6
D.2.3.2	Layout Plan	7
D.2.3.3	Minimum Diameter	8
D.2.3.4	Location	8
D.2.3.5	Isolation Valves.....	9
D.2.3.6	Source Water Connection.....	9
D.2.3.7	Pressure Testing and Leakage.....	9
D.2.3.8	Chlorine Residual and Bacteriological Testing.....	9
D.2.3.9	Temporary Sampling Ports and Flushing	10
D.2.3.10	Service Connections	10
D.2.3.11	Operation	11
D.2.3.12	Off-hours Corrective Action.....	11
D.2.3.13	Relocation of the Temporary Distribution System	12
D.2.4	Source Water Connection For New Water System	12
D.2.4.1	Connection Plan.....	12
D.2.4.2	Physical Separation.....	12
D.2.4.3	Use of Fire Hydrants	12
D.2.4.4	Temporary Connection and Backflow Preventer	12
D.2.4.5	Connection Point Relocation	13
D.2.5	Watermain Installation.....	13
D.2.5.1	Pipeline Layout Drawings	13
D.2.5.2	Watermain Laying Tolerance	14
D.2.5.3	Joint and Pipe Deflection	14
D.2.5.4	Joint and Thrust Restraint.....	14

D.2.5.5	Tracer Wire.....	15
D.2.5.6	Corrosion Protection.....	15
D.2.5.6.1	Metallic Mains	16
D.2.5.6.2	Wire Connections.....	16
D.2.5.6.3	Anode Offset.....	16
D.2.5.7	Bolts, Nuts and Washers	16
D.2.5.8	Warning Tape	16
D.2.5.9	Measurement and Payment	17
D.2.5.10	Wrapping.....	17
D.2.6	Hydrant, Valve and Chamber Installation	17
D.2.6.1	Setting of Hydrants.....	17
D.2.6.2	Hydrant Valves	18
D.2.6.3	Minimum Clearance	18
D.2.6.4	Chambers.....	18
D.2.6.5	Valve Box and Chamber Lid Adjustment Tolerance	19
D.2.6.6	Bolts, Nuts and Washers	19
D.2.7	Service Connections	19
D.2.7.1	Installation	19
D.2.7.2	Live Tapping.....	20
D.2.7.3	Tapping for Connections 100 mm and Larger.....	20
D.2.7.4	Pressure Testing.....	20
D.2.7.5	Disinfection.....	21
D.2.7.6	Union Couplings.....	21
D.2.7.7	Marker.....	21
D.2.7.8	Thrust Restraint	21
D.2.7.9	Grounding	22
D.2.8	Watermain Commissioning.....	22
D.2.8.1	General	22
D.2.8.2	Swabbing	23
D.2.8.3	Hydrostatic Pressure Test.....	24
D.2.8.4	Disinfection.....	24

D.2.8.5	De-chlorination.....	24
D.2.8.6	Chlorine Residual & Bacteriological Testing	24
D.2.8.7	Final Connection to Existing Water System.....	29
D.2.8.8	Tracer Wire Conductivity Test	30
D.2.8.9	Valve Positioning	31
D.3	SEWERS.....	31
D.3.1	Ontario Provincial Standard Specifications	31
D.3.2	Sewer Installation	31
D.3.2.1	Laying Tolerance	31
D.3.3	Maintenance Hole and Catchbasin Installation.....	32
D.3.3.1	Maintenance Hole Lid Adjustment Tolerance	32
D.3.3.2	Adjustment Unit Parging	32
D.3.3.3	Maintenance Holes Connections	32
D.3.3.4	Maintenance Hole Benching	33
D.3.4	Service Connections	33
D.3.4.1	Installation	33
D.3.4.2	Minimum Pipe Length.....	33
D.3.4.3	Line and Grade	33
D.3.4.4	Mainline Connection.....	33
D.3.4.5	Maintenance Hole Connections.....	34
D.3.4.6	Caps	34
D.3.4.7	Markers	34
D.3.4.8	Connection to Existing Materials	34
D.3.5	Commissioning.....	34
D.3.5.1	General	34
D.3.5.2	Leakage	35
D.3.5.3	Visual Inspection.....	35
D.3.5.4	Cleaning and Flushing.....	35
D.3.5.5	Deflection	36
D.3.5.6	CCTV Inspections	36

D.1 General**D.1.1 Ontario Provincial Standards**

All work shall be carried out in accordance with Ontario Provincial Standards (OPS) as referenced herein or in the Contract Documents. The Region of Waterloo and Area Municipal Design Guidelines and Supplemental Specifications for Municipal Services (SSMS or DGSSMS) are supplemental to the Ontario Provincial Standards and thus take precedence over the related specifications (OPSS's) and drawings (OPSD's).

D.1.2 Special Conditions or Special Provisions

These specifications may be altered on a project or Municipal specific basis within the Special Conditions or Special Provisions section of the Construction Contract.

D.1.3 Definitions

This section is intentionally left blank.

D.1.4 Environment**D.1.4.1 Blasting**

At no time is blasting or tunnelling to be undertaken without the prior written approval of the Chief Municipal Engineer.

D.1.4.2 Smog Alert

In the event of a Smog Alert, the Contractor shall work in accordance with the guidelines as specified below. Only Smog Alerts issued by the Municipality by 3:00 p.m. of the previous day will be applicable. A Smog Day Alert is issued with the Air Quality Index (AQI) as reported by the MECP is 50 or greater.

The Contractor shall take the following actions:

- Schedule the use of gas powered equipment to the morning hours
- Re-fuel equipment before 8:30 a.m. and after 3:00 p.m.
- Reschedule jobs that require the use of oil based paints, solvents and other organic based compounds. This also includes the use of cleaning solvents during daylight hours
- Avoid unnecessary idling of vehicle engines
- Reschedule any welding activities
- Reduce the use of gas-powered lawn mowers, generators, power washers, hedge trimmers, concrete saws, etc.

If, in the opinion of the Contract Administrator, a Smog Alert day restricts work related to a controlling operation from being completed, an extension of the specified working day allowance may be considered.

D.1.4.3 Discharge to Sewers

The discharge of water to the storm and sanitary sewers regardless of the source of water shall be as per the Municipal by-law.

D.1.5 Traffic Control

The Contractor's operations shall conform to the Ontario Traffic Manual (OTM) Book 7 (Temporary Conditions).

It will be the Contractor's responsibility to obtain the latest publication of Occupational Health and Safety Act (OHSA) and OTM Book 7.

D.1.6 Safety Requirements

No excavations regulated under provincial legislation shall commence until the Contractor has notified the Ministry of Labour in accordance with the Provincial Occupational Health and Safety Act and Regulations for Construction Projects, and no excavation shall commence on any existing street (with the exception of the **City of Guelph**) without a "Road Occupancy Permit" issued by the Municipality having jurisdiction.

D.1.7 Materials

All materials shall be as listed in Part C - Materials of these specifications or the Contract Documents.

A complete list of materials to be installed shall be provided to the Contractor Administrator prior to the start of construction or as specified in the Contract Documents.

D.1.8 Layout

Construction layout will be specified in the Contract Documents.

D.1.9 Pre-Condition Survey

If specified in the Contract Documents, this sub-section provides direction on what pre-construction activities are necessary.

For reconstruction projects, or where existing structures may be impacted, a pre-condition survey shall be completed to the Municipality's standards.

D.1.10 Site Preparation

This sub-section provides direction on site preparation operations, which may be required prior to initiating any excavation activities necessary for the installation of the works.

D.1.10.1 Clearing and Grubbing

Clearing and grubbing as specified in the Contract Documents and OPSS 201

D.1.10.2 Removals

Removals as specified in the Contract Documents and OPSS 490

D.1.10.3 Demolition

Demolition as specified in the Contract Documents

D.1.11 Excavation

This sub-section provides direction on excavation operations that the Contractor is required to perform to meet the technical requirements of the Contract Documents.

D.1.11.1 Temporary Stockpiling of Material

When insufficient space is available to allow placing of excavated material on the right-of-way, the Contractor shall load, haul and stockpile such excavated material at an offsite location arranged for by and at the sole expense of the Contractor. When the underground work has been installed, the Contractor shall, at the Contractor's own expense, bring back as much acceptable material so removed as may be required to properly refill the trench.

All surplus materials shall be disposed in accordance with the contract requirements for impacted materials and current regulations.

The Contractor shall provide a letter from the temporary offsite disposal site property owner accepting the material, placement, grading and restoration and releasing the Municipality of any responsibility to the satisfaction of the Municipality and OPSS 180.

D.1.11.2 Surplus Excavated Material

Material excavated during the construction of the works, which is surplus to the requirements for backfilling and which cannot be disposed on Municipal property adjacent to the site, as determined by the Contract Administer, shall be disposed or reused at locations arranged for, by, and at the sole expense of the Contractor. All disposal and proposed reuse sites for Excess Soil shall be subject to review and approval by the Municipality.

The Contractor shall provide a letter from the disposal or reuse site property owner accepting the material, placement and grading and releasing the Municipality of any responsibility to the satisfaction of the Municipality and OPSS 180.

D.1.11.3 Width of Trenches

Unless otherwise specified, the trench width at the top of the pipe shall be as specified in the SSMS drawings.

Trench side slopes shall conform to the requirements of the Occupational Health and Safety Act.

D.1.11.4 Open Trenching

Unless otherwise authorized in the Contract Documents or on the Construction Drawings, all underground works shall be constructed in open trench. When required or where designated, by the Contract Administrator to minimize surface disturbance, the Contractor shall use close sheeting or a trench box in accordance with the Occupational Health & Safety Act.

The Contractor shall not continue excavation and/or pipe installation where any part of a trench is left open for an unreasonable length of time in the opinion of the Contract Administrator. The

Contractor shall, when directed by the Contract Administrator, refill the trench or part thereof, and temporarily resurface the same, at the Contractor's own expense, and shall not again open such trench or part thereof until the Contractor is ready to proceed with the construction of the underground works.

D.1.11.5 Trenchless Installations

Trenchless installations shall be conducted in accordance with the Contract Documents and the Construction Drawings.

The Contractor may elect to utilize trenchless techniques; however, written approval shall be obtained from the Contract Administrator and the Chief Municipal Engineer.

D.1.12 Backfilling and Compaction

This sub-section provides direction on the placement, backfilling and compaction operations that the Contractor is required to perform to meet the technical requirements of the Contract Documents. Backfilling and compaction shall be carried out in a manner to not damage or dislodge the pipe, associated appurtenances, or utilities.

D.1.12.1 Bedding

The Contractor shall confirm the specified type of bedding and obtain the Contract Administrator's approval before any backfilling operations are undertaken. Backfilling and compaction shall be carried out continuously and immediately after the specified bedding material has been placed and approved by the Contract Administrator.

Bedding material shall be Granular "A" compacted to 100% Standard Proctor Maximum Dry Density. Recycled asphalt shall not be used wholly or in any part of the bedding material.

Where conditions warrant, and with the Contractor Administrator's approval, the Contractor shall sub-excavate to achieve a more stable base and replace with Granular "A" compacted to 100% Standard Proctor Maximum Dry Density. Where clear stone is used due to wet conditions or other uses, geotechnical recommendations shall be followed for the placement of filter fabric around the clear stone in the trench excavation.

D.1.12.2 Backfill Material

The trench above the specified bedding shall be backfilled with approved native material excavated from the trench or obtained elsewhere on the project, and shall be placed in layers not exceeding 300 mm, and shall be compacted to 98% Standard Proctor Maximum Dry Density.

D.1.12.3 Imported Backfill

Where approved native material is not suitable in the sole opinion of the Contract Administrator, and there is no approved native surplus material from other sections of the work, the Contract Administrator may order that the trench be wholly or partially backfilled with imported materials as approved by the Contract Administrator.

D.1.12.4 Backfill under Utilities

Unless otherwise specified in the Contract Documents or by the Utility having justification, backfill the trench under existing utilities using controlled density fill approved by the Contract Administrator. Extend the fill from the bottom of the trench or that level at which full compaction is achieved as specified to the underside of the utility being supported. The controlled density fill shall in all instances be placed across the entire trench width of the trench and shall extend a minimum of 150 mm on each side of the utility being supported measured along the length of the trench. Wrap the existing utility with a polyethylene bond breaker.

D.2 Watermains

This section provides direction on project coordination and notification requirements and also describes how watermains, service connections and associated appurtenances are to be installed, commissioned and tested to meet the technical requirements of the Contract Documents. This section also provides direction on the disinfection requirements of the MECP's Watermain Disinfection Procedure.

D.2.1 Ontario Provincial Standard Specifications

The watermain works shall be installed in accordance with OPSS 441 and 442 except as amended or extended herein.

D.2.2 Project Coordination

This sub-section defines responsibility with respect to project coordination objectives required prior to, during and following the water system construction.

D.2.2.1 Notification of Operating Authority

The Contractor shall notify the local operating authority of the water distribution system at least 48 hours prior to the commencement of any work that may affect the existing water distribution system.

D.2.2.2 Notification of Local Water Users

The Contractor shall notify all local water users who will be affected by the shutting down of any section of a permanent or temporary watermain system. Arrangements shall be made with the local operating authority regarding the methodology of notification.

The Contractor shall provide written hand delivered notification of the water service interruption at least two (2) full working days prior to the interruption to all affected water users. The notification letter / door hanger shall be to the local operating authority's standards and approved by the local operating authority prior to distribution.

The notification shall include:

- 24 hr. Contractor contact name(s) and phone number(s)
- Start date and time
- Duration of service interruption

At their discretion, the Municipality may provide door hangers or similar notices to the Contractor for distribution.

D.2.2.3 Shutting Down or Charging Mains

Only authorized operating authority personnel shall operate valves on existing watermains for the purpose of controlling water. No person other than the authorized operating authority personnel shall shut down or charge any section of existing watermain or operate any valve for the purpose of controlling water from existing watermains.

The Contractor shall provide the local operating authority with at least two (2) full working days advance notice when a change in control of the water is required. All necessary water supply interruptions shall be scheduled in cooperation with the local operating authority during normal working hours. If the Contractor elects to have the operating authority make system changes after normal working hours, the Contractor may be responsible for additional costs.

The Contractor shall operate only those valves, hydrants and curb stops installed in their Contract during the construction period prior to final connection to the existing distribution system. After final connection, only the local operating authority may operate the system.

Prior to excavation the contractor shall ensure that the watermain is de-energized by having the municipality operate the valves and confirm that is de-energized. When cutting and capping, always assume that the existing watermain is not fully restrained

Cut and caps shall:

- Be witnessed by the municipality (at least two full working days advance notice)
- Restrained with mechanical restraint and pre-cast concrete thrust blocks (no poured-in-place)
- Can add additional bracing between two pipes, but in conjunction with mechanical restraint.
- Pipe around is to be compacted with jumping jacks in small lifts
- Any cut and capped mains to remain live in the **City of Waterloo** and the City of Cambridge are to be provided with a 50mm dia. self-draining curb stop, service box and blow off complete with a ¼ turn ball valve above grade.

D.2.2.4 Water Interruption

The Contractor shall take all measures reasonable to ensure that water service is not interrupted before 9:00 a.m. and after 4:00 p.m. The Chief Municipal Engineer reserves the right to require that specified water users not be interrupted at all or that the interruption is limited to a certain time span. The Chief Municipal Engineer also reserves the right to require that any water interruptions be conducted outside of normal working hours.

D.2.2.5 Requirements Outside of Contract Limits

The Contractor shall ensure that construction activities will not unduly affect, in the opinion of the Municipality, the water distribution system outside of the contract limit.

D.2.3 Temporary Water Distribution System

D.2.3.1 General

In the event that existing water users must be taken out of service for a period exceeding eight (8) hours, or at the discretion of the Contract Administrator or the Chief Municipal Engineer, a temporary water distribution system shall be provided to all interrupted users.

This sub-section provides direction on the installation of Temporary Water Distribution System that the Contractor is required to perform to meet the technical requirements of the Contract Documents.

The temporary water system shall remain in service and not be removed until the Chief Municipal Engineer has approved the final connection of the new watermain to the existing system and authorized removal of the temporary water system.

The temporary watermain must run with a low flow once commissioned to maintain the quality of the water. Tested backflow prevention devices shall be connected to all flushing lines of the temporary main (at the main) and keep the line flushing. Acceptable devices include double check valve, testable ½" pressure vacuum breaker and reduced pressure principle. Backflow reports are to be provided as part of commissioning. The water is to be dechlorinated and discharged to a storm inlet as per CSA B64.10 (latest version).

Existing fire hydrants removed from service shall be bagged as out of service in accordance with the directions of the municipality.

The ends of the temporary watermain should be capped when arriving on site and kept capped until placed in use.

The watermain commissioning plan template in Part E is to be followed for temporary watermain plans (drawing to be included).

The inspector shall update the contract administrator whenever the following occurs:

- Buildings are placed on temporary water
- Buildings are taken off of temporary water
- Any changes in the sampling plan/ locations for approval prior to the change
- Any changes in the source for approval prior to the change
- Any breaches of the temporary water supply as soon as possible

D.2.3.2 Layout Plan

Prior to installing the temporary water distribution system, a detailed plan of the system shall be provided by the Contractor and approved by the Chief Municipal Engineer. Allow two weeks for review and approval. The temporary water distribution system shall be constructed as per the approved Layout Plan and any deviation from the approved Layout Plan is required to be resubmitted for re-approval by the Chief Municipal Engineer. The plan shall detail:

- Connection points to municipal system
- Backflow preventer size
- Materials for mainline and services

- Mainline and service sizes
- Sampling points
- List of addresses of affected properties including unit, apartment and suite numbers
- Emergency procedures and After Hours contact information
- Fire lines and any dead ends shall be identified and be blown out
- Other related information about the temporary water system

The Contractor shall demonstrate that the level of service to the water users will not be impacted and that the temporary system will supply water demands at pressures normal to the existing system.

The design Engineer shall identify large or exceptional water users and/or fire protection requirements. It is the contractor's responsibility to incorporate the requirements in their temporary water distribution system. The installation of temporary fire hydrants may be required.

The **City of Cambridge, Township of Woolwich** and **Region of Waterloo** require metering of temporary watermains and as such, the layout plan must include the size and location of the water meter. A water meter can be obtained from City of Cambridge Public Works, Township of Woolwich Operations Division, or Region of Waterloo Water Operations. Meter readings must be taken in accordance with contract specifications.

Service connections for temporary watermains are to be connected to property line / curb stop instead of hose bib. Service pits at property line to be securely fenced and left open until final connections are complete unless otherwise directed. For **City of Kitchener**, all service pits are to be backfilled immediately as per City of Kitchener CKSS.

D.2.3.3 Minimum Diameter

The minimum pipe size shall be 50 mm for mainlines and 19 mm for individual service connections.

The temporary water system shall be adequately sized to provide water at pressures normal to the existing water distribution system including the supply to fire suppression systems in serviced buildings. If temporary fire hydrants are required, the required fire flows shall be specified by the Chief Municipal Engineer. The Contractor may be requested to provide confirmation of the supply adequacy of the temporary watermain system by flow and pressure tests or by calculations.

D.2.3.4 Location

The temporary distribution piping shall be installed behind the sidewalk and service piping shall be installed along the edge of existing driveways to avoid grass-cutting conflicts.

All above ground piping shall be installed with appropriate ramping or burial such that the piping will:

- Not to be endangered by equipment or vehicular traffic

- Not pose a hazard for pedestrians (tripping, etc.)
- Provide a barrier-free access
- Be constructed to safeguard against vandalism and tampering

D.2.3.5 Isolation Valves

Isolation valves are required at the source water connection, branches (2 on 3 way, 3 on 4 way) and at every service.

D.2.3.6 Source Water Connection

The connection of the temporary water system to the existing distribution system shall be done in a secure location and be vandal and tamper resistant. A backflow preventer is required to separate the two systems as long as the temporary system is in service. The backflow preventer shall be a reduced pressure type assembly and shall be installed, maintained, and field-tested in accordance with the latest edition of CAN/CSA-B64.10.

At the beginning of the project on the first installation and all subsequent relocations, a certificate of operation shall be completed by an appropriately licensed technician and submitted to the Chief Municipal Engineer prior to the backflow preventer being put into service. Source water connections to fire hydrants are discouraged unless the Contractor can demonstrate that the hydrant has been disinfected and thoroughly flushed. The Municipality assumes no responsibility for the quality of water obtained from a hydrant. After disinfection, the hydrant shall be pressurized at all times that it serves as a source of potable water.

Where meters are required by the municipality they shall be installed upstream of the backflow prevention device.

For the **City of Guelph** the backflow prevention device (reduced pressure type assembly) must be certified by a certified tester and inspected by the Backflow Prevention Officer prior to being placed in service. Proper support of the device similarly as shown in City of Guelph Linear Infrastructure Standards will also be a requirement for approval.

D.2.3.7 Pressure Testing and Leakage

All above ground piping shall be regularly inspected to ensure leak tight connections at the beginning and during the period that the temporary water distribution is in use.

At the discretion of the Contract Administrator or the Chief Municipal Engineer, buried temporary water distribution piping shall satisfy hydrostatic pressure testing.

D.2.3.8 Chlorine Residual and Bacteriological Testing

After the temporary water system is installed (both mainlines and services) in its final location, but before service piping is connected to the water users, the temporary water distribution system shall satisfy the chlorine residual and bacteriological testing standards and protocols for the commissioning of new watermains as outlined in D.2.8.6. Samples must be collected at the end of each branch (individual services under 50 mm exempt unless designated by Contract Administrator) and at maximum 350 m intervals. See D.2.8.6.3 Sample Locations.

All sampler qualification, procedural standards, bacteriological and chlorine residual requirements detailed for commissioning new watermain distribution systems apply to testing the temporary water distribution system, including swabbing.

One week after the temporary water system is placed into operation and bi-weekly thereafter, chlorine residual and bacteriological samples shall be taken AT ALL SAMPLING LOCATIONS until the temporary system is decommissioned. The chlorine residual and bacteriological requirements after the temporary system is installed shall be that associated with the existing distribution system.

The Contract Administrator is to be contacted immediately if there is damage or loss of pressure to the temporary distribution system. This will require the contractor to perform another round of bacteriological testing.

If a water sample is shown adverse in accordance with O.Reg. 170/03 after the temporary water distribution system is in service, the Contract Administrator will notify the Contractor as soon as possible. The severity of the problem will be addressed and corrective action determined by the Chief Municipal Engineer. If a Boil Water or Drinking Water Advisory must be issued, or if the temporary water system must be disconnected, the Contractor shall supply bottled water or an alternate acceptable water supply to the interrupted water users. Before the temporary water system can be placed back into operation, it must satisfy the chlorine residual and bacteriological testing standards and protocols used to initially commission the temporary system and/or the requirements of the Medical Officer of Health, Public Health Department, Regional Municipality of Waterloo. The Contractor shall have forces available at all times during the corrective action and testing periods to conduct necessary work or assist with sampling as necessary and will be responsible for any costs incurred by the Municipality for corrective action and/or testing.

D.2.3.9 Temporary Sampling Ports and Flushing

Sampling ports are to be copper from the temporary main connection to the end (no plastic pipe) with a removable handle for the valve. Refer to detail E2-08. A gooseneck configuration or a tee configuration (both fully copper) are acceptable. A description of the sampling port or reference this section is required for the temporary watermain commissioning plan. Sample locations shall be kept clean and shall be located high enough to minimize any ground splashing back onto the sample port.

Once commissioned, the temporary watermain shall continuously flush at all dead ends to ensure water movement (dechlorinated and directed to the storm sewer, whenever possible). Specific tender requirements regarding sampling ports may be provided by the Municipality.

D.2.3.10 Service Connections

The service connection piping shall be installed and disinfected at the same time as the main line in order that disinfection is accomplished on the service piping. The final connection to the water user shall not be made until the chlorine residual and bacteriological testing requirements have been satisfied. During service connections, the Contractor shall minimize the portion of the system depressurized.

A check valve shall be installed on the service connection between the mainline and the connection to the water user.

Prior to connection to water users, individual service lines shall be thoroughly flushed. The final connectors shall be spray-disinfected and swabbed with a minimum 1% and maximum 5% solution to disinfect the fittings. The Contractor shall arrange for the plumbing system to be flushed to remove any elevated chlorine residuals.

In the **City of Cambridge** and the **Township of Woolwich** a service connection to a private building shall be at an outside hose bib. An individual WYE type connector shall be installed. A vacuum breaker shall be installed on the service connection. In the event that this scenario is not possible, it is the responsibility of the Contractor to determine how to provide temporary water service to the satisfaction of the property owner. Any excavation on private property or internal plumbing modifications shall only be done after written approval is obtained from the property owner and applicable plumbing permits obtained. A copy of any written approvals shall be provided to the Contract Administrator.

The Contractor is responsible to provide an appropriate connection to the water user. The property owner is under no obligation to allow the temporary water system to be connected to their internal system at any location other than on the public side of the curb stop. In the event that a property owner will not permit an above ground connection as typical, it shall be the Contractor's responsibility to make alternate arrangements to service the property. In lieu of making above-ground temporary servicing, the Contractor has the option to connect the temporary distribution system to the public side of the existing curb stop.

The **Cities of Kitchener, Guelph and Waterloo**, and the **Townships of North Dumfries, Wellesley, and Wilmot** requires that service connections for temporary watermains are to be connected to property line / curb stop instead of hose bib. **Cities of Waterloo, Guelph** and the **Townships of North Dumfries, Wellesley, and Wilmot** require service area at property line to be fenced in and left open until final connection. For the **City of Kitchener**, the service pits are to be backfilled immediately as per City of Kitchener CKSS.

D.2.3.11 Operation

The temporary water distribution system shall be continually pressurized after the bacteriological testing is completed and be capable of supply normal water demands throughout its installation.

In the event of a main or service break, the Contractor shall advise the Chief Municipal Engineer and take immediate steps to minimize water loss and to avoid system contamination. Each end of the broken pipe shall be elevated in a manner to avoid backflow into the pipe. As per MECP Watermain Procedures all fittings used in the repair and the pipe ends shall be spray-disinfected and swabbed with a minimum 1% and maximum 5% solution to disinfect the connection. At the discretion of the Contract Administrator or the Municipality, a round of chlorine and bacteriological samples may be taken to ensure the integrity of the system.

D.2.3.12 Off-hours Corrective Action

In the event that corrective action is needed to the temporary water distribution system outside of normal working hours, the Contract Administrator and/or the Municipality will attempt to contact the Contractor to take corrective actions. If, in the sole opinion of the Municipality, the

Contractor is unable to make the corrections in a timely manner, the Municipality may direct their own forces to take corrective steps. The Contractor will be responsible for any costs incurred by the Municipality.

D.2.3.13 Relocation of the Temporary Distribution System

The relocation of the temporary water system either in whole or parts by any means without conducting and passing the chlorine residual and bacteriological requirements shall not be permitted. Relocation here is defined as depressurising and moving the pipework in order to service other water users.

D.2.4 Source Water Connection For New Water System

This sub-section provides information on submission requirement and procedures to be followed by the contractor in order to acquire approval to complete the Source Water Connection for the temporary water system and/or the testing and/or commissioning of the watermain system. Where meters are required by the municipality they shall be installed upstream of the backflow prevention device.

D.2.4.1 Connection Plan

Prior to the use of municipal water for testing and/or commissioning the new water system, the Contractor shall submit a plan detailing the source water connection, tapping machine, location via the Contract Administrator to the Chief Municipal Engineer for approval. The Contractor may also include the plan required for chlorine and bacteriological testing with this submission. The Contractor shall allow two (2) weeks for review and approval.

D.2.4.2 Physical Separation

All connection points between the existing water distribution system and new watermains, including temporary water distribution systems, shall be kept physically separated until the watermain has successfully passed commissioning and testing requirements.

D.2.4.3 Use of Fire Hydrants

Source water connections to fire hydrants are discouraged unless the Contractor can demonstrate that the fire hydrant has been disinfected and thoroughly flushed. The Municipality assumes no responsibility for the quality of water obtained from a fire hydrant. After disinfection, the fire hydrant shall be pressurized at all times that it serves as a source of potable water.

D.2.4.4 Temporary Connection and Backflow Preventer

To facilitate watermain commissioning, a temporary connection to the existing water distribution can be made through the use of a temporary or "jumper" connection equipped with a backflow preventer as detailed in the SSMS standard drawing E2-17. The connection to the existing distribution system shall be done in a secure location and be vandal and tamper resistant and shall be no larger than 50 mm diameter. Multiple jumpers or larger connections are acceptable with the approval of the Chief Municipal Engineer.

The backflow preventer shall be a reduced pressure type assembly and shall be installed, maintained, and field-tested in accordance with the latest edition of CAN/CSA-B64.10.

At the beginning of the project on the first installation, and all subsequent relocations, a certificate of operation shall be completed by a licensed plumber and submitted to the Chief Municipal Engineer prior to the backflow preventer being put into service. The backflow preventer must be re-certified when the unit is relocated. The existing distribution systems and the backflow preventer shall be physically disconnected from the test section during hydrostatic testing.

D.2.4.5 Connection Point Relocation

In the event that the connection point of the new watermain to the existing watermain distribution system is in a location that is impractical to install a temporary jumper connection or carry out testing requirements, the Contractor may elect, or be directed by the Chief Municipal Engineer, to re-locate the connection point to a more suitable location. This situation may occur if the connection point to the existing water distribution system is within the travelled portion of a roadway, would raise safety concerns or may cause environmental or property damage if an excavation were left open or pipe work exposed aboveground.

The Contractor shall carry out the disinfection of the watermain installed to relocate the connection point in accordance with AWWA 651 and the procedures outlined under “Final Connection” for new watermains.

After the watermain connection has been installed, the Chief Municipal Engineer or the Contract Administrator may elect to conduct additional chlorine residual and bacteriological testing in accordance with the requirements outlined for new watermains in D.2.8 to verify the disinfection of the watermain. If the watermain connection fails either the chlorine residual or bacteriological requirements, the Chief Municipal Engineer will direct corrective action and the Contractor shall cooperate fully.

D.2.5 Watermain Installation

This sub-section provides direction on the watermain installation operations that the Contractor is required to perform to meet the technical requirements of the Contract Documents. As per OPSS 441 “All pipes up to and including 600 mm shall be delivered to the Work Area with end covers”.

D.2.5.1 Pipeline Layout Drawings

Prior to the Pre-Construction Meeting, Pipeline Shop Drawings for mains larger than 300 mm diameter shall be prepared by the pipe manufacturer or supplier for the pipeline system and shall be stamped and signed by a professional engineer licensed by PEO, with three copies provided to the Contract Administrator for review and additional copies as necessary provided to the contractor for field use. Pipeline Layout Drawings are required regardless of the pipe material to be installed, and shall include as a minimum:

- Identification of pipe size and standard for each pipe size (DR rating, pressure rating, manufacturer, product name) the locations of all chambers, fittings, etc., related to design chainage
- Pipe deflection locations and values, and method of deflection/fittings proposed
- Pipe elevations and grades

- Restraint length calculations (where not provided on the design drawings)
- Restraint lengths and type of restraint for each fitting

D.2.5.2 Watermain Laying Tolerance

The allowable laying tolerance from that shown on the Construction Drawings for all sizes and along the entire length of watermains is as follows:

Horizontal: 50 mm

Vertical: 25 mm

D.2.5.3 Joint and Pipe Deflection

The deflection of joints shall not exceed that recommended by the pipe manufacturer. Pipe barrels shall not be deflected to any degree or placed under lateral or vertical stress.

D.2.5.4 Joint and Thrust Restraint

Mechanical joint restraints shall be installed on mains of all sizes:

- On all main valves, hydrant leads, flushing and swab ports, and all service laterals 100 mm or greater in size
- At all horizontal and vertical bends and tees (one pipe length on each side of the bend/tee)
- In areas subject to settlement
- As directed by the Contract Administrator and/or Chief Municipal Engineer
- All joints to be restrained a minimum 10 m from an appurtenance or as per approved shop drawings, or as per manufacturer's specifications

In addition to mechanical joint restraint, precast or poured-in-place concrete thrust blocks, shall be installed on mains up to and including 300 mm dia.:

- As shown on the Construction Drawings
- As shown on the pipeline Shop Drawings
- At all horizontal and vertical bends and tees
- As shown on the hydrant detail drawing
- As shown on approved shop drawings
- As directed by the Contract Administrator and/or Chief Municipal Engineer
- Using forms and concrete tested to 20mPA for poured –in-place concrete thrust blocks

Precast thrust block size for watermain smaller than 300mm to be 550x400x200, for watermain 300mm and larger block size to be 900x900x200. Threaded rod shall not be installed unless

written permission is obtained from the Contract Administrator with the approval of the Chief Municipal Engineer.

D.2.5.5 Tracer Wire

The tracer wire shall be installed as per the SSMS standard drawings and taped to the top centre of all non-metallic watermain and service piping at 5m intervals.

Splices and other wire to wire connections shall be made by using Dryconn King 9 Dark Blue #10999 waterproof connector or using a copper split bolt and Dryconn Visilock with SmartGel splice box (#98010) as shown on Drawing E2-15. Connections shall only comprise the approved wire size and quantity combinations specified for the connector.

For horizontal directional drilling applications or pipe bursting applications, the strength (gauge) of the tracer wire as well as the number of tracer wires required shall be confirmed by the Engineer.

For copper split bolt connections, the connector and bare wire shall be wrapped with dielectric tape and over-wrapped with vinyl tape.

Tracer wire as part of a cathodically protected watermain on non-metallic systems shall **not** be connected to new or existing metallic watermain piping and/or associated fittings that are connected to the metallic watermain in order not to interconnect corrosion protection systems. Nor shall the new tracer wire be connected to any existing tracer wire that is not part of a cathodically protected system. A 12lb or larger anode shall be installed at the terminus of the tracer wire which is not otherwise connected to an existing tracer wire.

For services, the tracer wire shall be connected to the nut provided on the main stop and curb stop. If the private side water service is metallic then the tracer wire is **not** to be attached to the curb stop. Instead, it is to be terminated using a Dryconn #10999 waterproof connector and a 12lb or larger anode is to be attached to the curb stop to provide corrosion protection for the curb stop and private side metallic water service. (See drawing E2-05).

A maximum of 200 m spacing, or as shown on design drawings, must be provided with Regional test ports. Also, test ports are to be installed at each end of trunk watermain.

For **City of Waterloo**, refer to the City of Waterloo Tracer Wire Specification located on the City of Waterloo's website for standards and guidelines for tracer wire installation.

D.2.5.6 Corrosion Protection

For non-metallic watermains with metallic valves, fittings, appurtenances and non-metallic service laterals, one anode shall be attached to the tracer wire and metallic valve, fitting and appurtenance at intervals identified on the Construction Drawings. Under no circumstances is anode spacing to exceed 100 metres. **In Township of Woolwich a max. 50m spacing between anodes is required.** The anode shall be connected to the tracer wire and metallic valve, fitting or appurtenance as detailed in the SSMS Standard Drawings.

The tracer wire shall be connected to all metallic fittings as detailed in the SSMS Standard Drawings.

A minimum 24lb anode shall be installed at the terminus of all tracer wire not connected to an existing tracer wire or metallic valve, fitting or appurtenance.

Anodes on CPP watermains shall be placed in accordance with the construction drawings and specifications.

In the **City of Guelph**, and in the **City of Waterloo**, the anode shall not be connected to the tracer wire and shall only be connected to each metallic fitting. The following anode sizes are required: 12lb for inline fitting, 24 lb for hydrant, 12 lb for curb stop and main stop (on copper service) installed on PVC watermain. All valves 300mm and larger shall have a 24lb anode. A brass grounding clamp shall be used to connect the anode lead to the fitting.

D.2.5.6.1 Metallic Mains

If required for metallic watermains (i.e. DI), the anode placement shall be done in accordance with the construction drawings and contract specifications. The copper lead wire of the anode shall be wrapped once around the watermain before being connected to the watermain or fitting using a copper split bolt or brass clamp connection. The copper lead wire is to be connected to copper service connections via main stops provided with electrical ground connectors.

The use of polyethylene bags or wrapping is not an accepted method of corrosion protection.

D.2.5.6.2 Wire Connections

Connections shall use a Dryconn, King 9 Dark Blue waterproof connector (#10999), a Dryconn, VisiLock with SmartGel waterproof splice box (#98010) with a brass split bolt or a brass split bolt connector. If a brass split bolt connector is used then the connection must be protected and wrapped with dielectric tape and covered with vinyl tape or an approved petrolatum tape system to prevent corrosion. Please refer to drawing E2-15.

For **City of Waterloo**, refer to the City of Waterloo Tracer Wire Specification located on the City of Waterloo's website for standards and guidelines for tracer wire installation.

D.2.5.6.3 Anode Offset

Anodes are to be placed parallel to the watermain and must be in native soil with a minimum offset of 0.3 metres to a maximum offset of 1.0 metre from the watermain. At no time is the anode to be placed in the pipe bedding material or virgin road granular material.

D.2.5.7 Bolts, Nuts and Washers

Bolts, nuts and washers used on buried fittings shall be Cor-Ten or stainless steel.

All bolts, nuts and washers shall be covered with a three part corrosion protection system consisting of past, mastic and petrolatum tape (regardless of whether it is coated or not), and shall be installed in accordance with the manufacturer's instructions.

D.2.5.8 Warning Tape

Warning tape for non-potable watermains shall be placed on top of the granular pipe bedding over the centreline of the pipe and secured from movement during backfilling.

D.2.5.9 Measurement and Payment

Unless otherwise provided for in the Contract Documents, measurement and payment for the installation of watermain will be in accordance with the Ontario Provincial Standards. If not otherwise specified, the supply and installation of joint and thrust restraint, tracer wire, warning tape and corrosion protection systems shall be considered to be included as part of the watermain installation item.

D.2.5.10 Wrapping

In all municipalities for all watermains less than 450 mm diameter, all metallic fittings (excluding curb/main stop and brass fittings) and appurtenances including saddles, valves, tees, bends, restraints, fire hydrant boot bolts etc. are to be wrapped with an approved petrolatum system consisting of paste, mastic and tape. In **Township of Wilmot** all sizes of appurtenances including saddles, valves, tees, bends etc. are to be wrapped with an approved petrolatum system consisting of paste, mastic and tape. The **Township of Woolwich** also requires that all curb/main stops and brass fittings are to be wrapped.

For watermains 450 mm diameter and greater, only the bolts of the appurtenances are to be wrapped with an approved petrolatum system consisting of paste, mastic and tape.

D.2.6 Hydrant, Valve and Chamber Installation

This sub-section provides direction on the installation of hydrants, valves and chambers that the Contractor is required to perform to meet the technical requirements of the Contract Documents.

Backfill for hydrant is 19 mm clear stone surrounded with filter cloth and Granular A or approved native backfill as shown on SSMS drawing E2-01. Backfill for valve is 19 mm clear stone surrounded with filter cloth from the top of bedding to the upper gland (just below the operating nut) and Granular A from the upper gland to the subgrade. Backfill for chambers is select subgrade material in accordance with OPSS 1010 or as dictated by the Chief Municipal Engineer.

D.2.6.1 Setting of Hydrants

Unless otherwise specified, hydrants shall be installed in accordance with the appropriate SSMS standard drawing.

Hydrants set in areas with a high ground water table shall have the hydrant drain hole plugged as directed by the Contract Administrator.

Horizontal and vertical bends shall not be installed in the hydrant lead unless written approval is obtained from the Chief Municipal Engineer.

For non-metallic watermains and/or hydrant leads, the tracer wire shall be connected to the hydrant tee, valve and boot, then brought up the lower hydrant barrel to 100mm above the surface in a 32mm diameter nonmetallic electrical conduit. The conduit is to have 300mm

buried with 100mm above grade with the tracer wire placed inside (400mm total length of conduit). The tracer wire is then looped back down the hydrant barrel, without being spliced, and back along the hydrant lead without connecting the tracer wire to the boot or valve as per the SSMS standard drawing E2-01. In the **City of Guelph** and **City of Waterloo** the tracer wire is **not** to be attached to the hydrant valve and boot, as only anodes are to be attached.

Fire hydrants not in service shall be bagged as out of service as directed by the municipality. In the **City of Kitchener** and **Township of Woolwich** rings, not bags are used to identify hydrants out of service, contact 741-2529 for every hydrant called out of service and to obtain rings (and back into service).

D.2.6.2 Hydrant Valves

Unless otherwise specified, valves shall be installed in accordance with the SSMS standard drawing E2-01 and E2-02. Hydrant valves shall be restrained directly to the main using anchor tees, except in the **City of Guelph**.

For non-metallic watermains, the tracer wire shall not be brought to the surface inside of valve boxes. If directed by the Municipality, the tracer wire may be brought up the outside of the valve box and installed through a grommet near the surface. The tracer wire and possibly an anode are to be attached to the metallic hydrant valve. In the cities of **Guelph** and **Waterloo** only an anode is to be attached to the hydrant valve, **not** the tracer wire.

Road levellers (inside screw) of any style shall not be installed. The valve box must be raised to final grade.

D.2.6.3 Minimum Clearance

D.2.6.3.1 Fire Hydrants

The minimum clearance from above ground obstructions to fire hydrants shall be as follows:

Behind	0.6 m
Each Side	2.0 m
Front	clear to the curb line

The installation of bollards shall be as directed by the Municipality.

D.2.6.3.2 Valves

The minimum clearance from above ground obstructions to valves shall be 2.0m.

Avoid installation of valves in curbs, ramps, or sidewalks.

D.2.6.4 Chambers

Unless otherwise specified, chambers shall be installed in accordance with the SSMS standard drawings. For non-metallic watermains, the tracer wire shall be brought up to the underside of the chamber lid to accommodate connection to a "locator" in a manner to avoid entrance to the chamber. Secure the tracer wire within the chamber within 300 mm of the final grade with a

minimum of 600 mm of loose wire. Fasten the tracer wire neatly within the chamber and at the chamber entrance using acceptable wire fasteners.

D.2.6.5 Valve Box and Chamber Lid Adjustment Tolerance

Maintenance hole frames and lids shall be adjusted so that when tested with a 3 m straight edge in any direction of the surface, shall meet the following grade variance requirements between the bottom of the straight edge and the surface of the asphalt or frame and appurtenance.

+Gap, mm	Action
Up to 7	Acceptable
Greater than 7	Unacceptable

D.2.6.6 Bolts, Nuts and Washers

D.2.6.6.1 Buried Installations

Bolts, nuts and washers used on buried fittings shall be Cor-Ten or stainless steel.

Bolts, nuts and washers used on fittings in chambers shall be stainless steel.

If the Contractor elects to use Cor-Ten or stainless steel bolts, nuts and washers on buried valves or fittings, the entire connection shall be covered with a petrolatum tape system (paste, mastic and tape) which shall be installed in accordance with the manufacturer's instructions.

D.2.6.6.2 Chambers

Bolts, nuts and washers within chambers shall be stainless steel plus a petrolatum tape system. The use of zinc or cadmium coated bolts, nuts and washers are not permitted within chambers.

D.2.7 Service Connections

This sub-section provides direction on the installation of service connections that the Contractor is required to perform to meet the technical requirements of the contract specification.

D.2.7.1 Installation

Unless otherwise specified, service connections shall be in accordance with the SSMS standard drawings.

D.2.7.1.1 Procedure for New Water Service Connection to Existing at Property Line

The below procedure should prevent blockages occurring in the existing water service piping.

After exposing the existing water service at the property line, the house water meter valve should be opened and the line back flushed from the temporary supply until the water runs clear and then close the meter valve again.

After the new water service is connected to the existing water service, the new service should be charged, curb stop opened, meter valve opened and outside hose bib opened to flush this line until it runs clear.

If access to the meter valve is not possible at the time of connection for back flushing, then the contractor should proceed with the connection at the property line, but keep the curb stop closed until access is available. Then the curb stop can be opened, water meter valve opened and outside hose bid opened to flush this line until runs clear.

When there is damage to a service in the roadway, the service from the main to the face of sidewalk shall be replaced. If the service is metallic then a metallic pipe shall be used. If the service is plastic then a plastic pipe shall be used. For the connection at the property line if the existing service is metallic then a new metallic service is to be installed at the back of the curb stop to the existing water service. If the existing water service is plastic then a new plastic pipe shall be used.

Refer to drawing E2-03 for installation details for frost collar around curb boxes located in driveways.

D.2.7.2 Live Tapping

Service connections shall be completed under pressure (live tapping) for the following:

- All service connections 50 mm and under on metallic watermains
- All service connections 50 mm and under on non-metallic watermains utilising a service saddle
- All connections utilising a tapping sleeve and valve
- Inspect connections to ensure drip tight prior to backfilling
- All tapping in the **City of Guelph** shall be arranged with and carried out by City of Guelph or approved contractor. All tapping in the **City of Kitchener** shall be arranged with and carried out by City of Kitchener staff. Arrangements shall be made a minimum of 48 hours in advance. Earliest appointment is 9:00am.
- Tapping sleeves shall be used for temporary watermains
- Tapping is the preferred construction method over cut in tees

D.2.7.3 Tapping for Connections 100 mm and Larger

All tapping of watermains for connections 100mm and larger shall be performed by municipal forces or a designated watermain tapping contractor approved by the Chief Municipal Engineer. Tapping shall be done only when the watermain is under pressure (live tapping) and shall be inspected to ensure a drip tight connection prior to backfilling. Tapping is the preferred construction method over cut in tees

The **City of Waterloo and City of Cambridge** do not allow size on size tapping and requires municipal forces to provide on site oversight during the tapping.

D.2.7.4 Pressure Testing

New Development

All new services shall be pressure tested to the valve or curb stop at the property line as per OPSS 441.

Reconstruction Projects

All new water services shall be pressure tested to the valve or curb stop at the property line as per OPSS 441.

D.2.7.5 Disinfection

All new water services shall be super-chlorinated, thoroughly flushed, and disinfected at the same time as the watermain.

All services 100 mm and larger shall be sampled to ensure these services pass the chlorine residual and bacteriological requirements for new watermains.

Where existing services are connected to a new watermain within the watermain trench, the Contractor shall ensure that the new service material is free of dirt and debris and the connection is made under as clean conditions as possible. The Contractor shall make arrangements to thoroughly flush the service through an inside or outside hose bib for a minimum of 3 to 5 minutes or until the water runs clear and chlorine residuals have reduced to levels normal to the existing distribution system. If there is any question as to the water quality, the Contract Administrator may request a water sample for bacteriological analysis to the standards outlined for new watermains. In the event that the water sample is adverse, the Contractor shall take whatever corrective action is deemed necessary by the Contract Administrator and the Chief Municipal Engineer.

D.2.7.6 Union Couplings

Only one (1) union per service will be allowed on copper services over 20m and no unions are allowed for non-metallic services.

Service pipe union couplings shall not be installed under gravel or asphalt road surfaces.

The above does not apply where it is normal to the project that existing services will be connected to a new watermain in the watermain trench. In this case, only one (1) union coupling appropriate to connect the new and old service material shall be installed.

When there is damage to a non-metallic service, the service from the main to the curb stop at the property line shall be replaced. The same material shall be used, unless the material is in conflict with the approved material list.

D.2.7.7 Marker

For new construction where the new service is not connected to an existing private system, the ends of service connections shall be marked at the curb box by extending a 38 mm x 89 mm timber marker vertically from the curb stop to a height of 1.0m above finished ground level. The exposed end of these marker stakes shall be painted blue.

D.2.7.8 Thrust Restraint

Thrust restraint shall be accomplished by approved mechanical joint restraints and concrete thrust blocks. Redi-rods or threaded rods are not allowed due to long term corrosion problems.

D.2.7.9 Grounding

To reduce the risk of shock, the Contractor shall ensure that jumper cables (or other appropriate grounding) are used on all metallic services prior to working on a water service, curb stop, or removing a meter.

D.2.8 Watermain Commissioning

This sub-section provides information on the submission and testing requirements and procedures to be followed by the Contractor to complete the commissioning of the watermain.

For watermain relining, see municipality for requirements.

D.2.8.1 General

In order for a watermain to be considered for acceptance by the Chief Municipal Engineer, the following procedures and tests shall be successfully completed by the Contractor in the presence of the Contract Administrator:

- swabbing
- hydrostatic pressure test
- disinfection
- de-chlorination
- chlorine residual and bacteriological sampling tests
- final connection
- tracer wire conductivity test
- valve positioning

All field tests conducted in this subsection shall be performed in the presence of the Municipal Staff and Contract Administrator. The contractor/ developer may be responsible for the cost of water to undertake the field tests. Check with the individual municipalities operating authorities for associated costs.

Prior to the initiation of the watermain commissioning procedures, the Contractor shall submit a Watermain Commissioning Plan for review by the municipality. The Watermain Commissioning Plan shall contain a complete description of all the steps the Contractor will undertake to ensure the watermain satisfies all the testing and sampling requirements. In addition to the Watermain Commissioning Plan for development that is approved under a Subdivision Agreement, the developer must also provide a Chlorine Residual Maintenance Plan.

The Watermain Commissioning Plan, and Chlorine Residual Maintenance Plan, if required, shall be submitted a minimum of two (2) weeks in advance of the initiation of the watermain commissioning. This Watermain Commissioning Plan shall also include the specific reporting protocols as described under the particular commissioning procedures in the following

sections. The Watermain Commissioning Plan is also to be followed for temporary watermain plans (drawing to be included). Only clean “water only” tools are to be used on the watermain and appurtenances.

The following templates and checklists are included in **Part E**:

- A Watermain Commissioning Plan template E-T1
- Chlorine Residual Maintenance Plan requirements – Sheet E-DS3
- New Watermain Disinfection Checklist (NEW)
- New Watermain Connection Checklist (NEW)

D.2.8.2 Swabbing

Prior to disinfection, all sections of watermain shall be swabbed using a minimum of four new foam swabs. Swabs shall be polyurethane with a density of 24.7 kg/m³ and shall have a minimum diameter 50 mm larger than the diameter of the watermain and have a minimum length of one and one half times its diameter.

The Contractor shall charge the watermain fully with water prior to the commencement of swabbing. The water used to conduct the chlorine residual and bacteriological testing shall be **normal** to the existing water distribution system. In most cases, test water can be supplied by the adjacent existing distribution system; however if this source is not available, or the Contractor elects not to use, then potable water from a prior Municipally approved location within the existing water distribution system may be brought to the watermain under consideration at the Contractor’s expense.

For mains 300 mm diameter or smaller, swabs shall be propelled through the watermain at a speed of 0.5 to 1.0 metre/second using potable water. For mains greater than 300 mm diameter and for mains where the Chief Municipal Engineer requires a velocity lower than 0.5 m/s, the velocity calculations provided in the Watermain Commissioning Plan will be reviewed by the Chief Municipal Engineer.

The Contractor shall discharge water to an approved outlet ensuring all required erosion and sediment control and dechlorination measures are followed. The Contractor shall demonstrate how the appropriate swabbing velocity will be achieved.

Stubs for future watermains longer than one (1) pipe length shall be swabbed. Servicing stubs 150 mm diameter and larger and longer than one (1) pipe length shall be swabbed only if specified in the contract documents.

The swabbing shall continue until the discharge water runs clear within ten seconds of the last swab exiting the discharge point.

After swabbing has been completed, the Contractor shall flush every fire hydrant lead, stub and service.

The Contractor shall mark, number, and demonstrate to the contract Administrator that all swabs or parts thereof, have been retrieved. The Contractor shall be liable for costs associated with damage caused by and retrieving swabs that, for whatever reason, escape into the

existing water distribution system. The Contractor shall provide a letter co-signed by the Contract Administrator that all swabs were retrieved.

Swabbing reports shall be provided to the Municipality as part of commissioning.

D.2.8.3 Hydrostatic Pressure Test

Hydrostatic pressuring testing shall be carried in accordance with OPSS 441. A minimum of the specified test pressure shall be applied to all points (including high points) in the watermain section being tested. The Contract Administrator shall witness the pressure test and provide written confirmation with the attached form provided in Part E.

D.2.8.4 Disinfection

Disinfection shall be carried in accordance with MECP Watermain Disinfection Procedure (as related to new watermain) and AWWA C651 (last version). As per AWWA C651, acceptable types of chlorine include sodium hypochlorite, calcium hypochlorite (conforming to ANSI/AWWA B300), and NSF certified liquid chlorine (conforming to ANSI/AWWA B301) in original containers. Type of chlorine must be stated in the commissioning plan.

Pre-post chlorination levels for all sample locations shall decrease no more than 40% of the initial concentration to a maximum decrease concentration of 50mg/L after 24 hours. This test shall be witnessed by the contract administrator and the results shall be provided to the City.

The Contractor shall flush every part of the water system including fire hydrant leads, stubs for future watermains and services to remove all super chlorinated water.

In the **City of Guelph** the entire main shall be re-swabbed with a minimum of one clean swab to remove the majority of super chlorinated water prior to flushing.

For more information regarding disinfection procedures please refer to the latest MECP procedure and the sample watermain commissioning plan in Part E.

D.2.8.5 De-chlorination

All water wasted shall be discharged into the stormwater system and shall be neutralized to provide a total chlorine residual of less than 0.2 mg/l. Acceptable dechlorination/ neutralizing agents are sodium thiosulphate and hydrogen peroxide. Neutralizing agent shall be noted in the commissioning plan. The Contract Administrator will monitor the discharge of waste water. Where detrimental effects may be suffered by plants and/or animals in the natural environment, the wasted water shall be neutralized to provide a total chlorine residual of less than 0.002 mg/l (2 ppb) (Provincial Water Quality Objective) at the outfall.

The Chief Municipal Engineer reserves the right to direct the Contractor not to exceed a specified limit or discharge rate.

D.2.8.6 Chlorine Residual & Bacteriological Testing

D.2.8.6.1 Procedure

Prior to the commencement of chlorination residual and bacteriological testing, the Contractor shall submit a sampling plan detailing the source water location, final connection locations and

the sampling locations via the Contract Administrator to the Chief Municipal Engineer for approval. The Contractor shall allow two (2) weeks for review and approval. Appropriate coding or labelling shall be provided on the plan to clearly correlate the sample results to the sampling locations.

Before the watermain can be approved for connection to the existing water distribution system, two (2) consecutive rounds of water samples, taken at least 24 hours apart, shall pass both the chlorine residual and bacteriological standards outlined below for consecutive samples. Prior to chlorine residual and bacteriological testing, all other testing (i.e. hydrostatic, disinfection) shall be completed and any super-chlorinated water removed from all portions of the watermain system under consideration including fire hydrant leads, stubs, branches, services, etc.

The watermain test section shall **not** be disturbed or flushed during the period between the 1st and 2nd sampling rounds, except to obtain a water sample.

The watermain shall be continually pressurized from the start of bacteriological testing until the final connection to the existing system is undertaken.

Only after the tested watermain has passed all chlorine residual and bacteriological requirements and has been approved to be put into service by the Chief Municipal Engineer, shall the watermain be connected to the existing water distribution system.

After the completion of the final connection, the watermain shall be re-pressurized by the existing distribution system as soon as possible.

The Chief Municipal Engineer or the Contract Administrator may request additional bacteriological sampling after the final connection has been made as a precaution against or in response to possible contamination during the final connection.

D.2.8.6.2 Source Water

The water used to conduct the chlorine residual and bacteriological testing shall be normal to the existing water distribution system. In most cases, test water can be supplied by the adjacent existing distribution system; however if this source is not available, or the Contractor elects not to use, then potable water from a prior Municipally approved location within the existing water distribution system may be brought to the watermain under consideration at the Contractor's expense.

Should the Contractor elect to undertake a bacteriological sample of source water from a municipal system, the sample must be taken from the new watermain side of the backflow preventer. In the event that this sample is adverse, the Municipality may undertake a sample of the municipal system to verify the results.

D.2.8.6.3 Sample Locations

Chlorine residual and bacteriological testing samples shall be taken:

- Backflow preventer, only used to test chlorine not to sample for bacteria
- At the end of each branch or stub (excluding fire hydrants)

- At the end of services 100 mm or larger
- A maximum of every 350 metres along the watermain test section
- A maximum of 150m from the source water connection
- Any additional locations as required to ensure that adequate chlorination is achieved (e.g. to ensure that both sides of a crescent are chlorinated)
- As identified in the Special Provisions
- As directed by the Contract Administrator
- As directed by the Chief Municipal Engineer

Sampling of fire hydrant leads is not required unless the Contractor has elected or is requested to utilize a fire hydrant location to satisfy any of the above sampling location criteria. Regardless of whether fire hydrants are used for a sampling location, all fire hydrant leads shall be thoroughly flushed to remove debris and any super-chlorinated water.

In the event that the maximum distance criteria cannot be satisfied or if additional sampling points are required by the Municipality, the Contractor may be directed by the Municipality to install sampling taps on the watermain for the sole purpose of obtaining a water sample. During the completion of the final connection or after the watermain has been commissioned the Contractor shall remove the sampling line and replace the main stop with a plug. Stainless steel plugs must be installed on saddles and brass plugs for ductile iron.

All sampling ports shall be copper or stainless steel lines 25 mm or smaller and brought a minimum of 1.0m above the surface. The Contractor shall be available to operate underground valves as necessary during sampling. See SSMS E2-08

If the sampling stations are removed they must be kept in a hygienic manner and there must be at least three per site in the event of an adverse water sample and resampling is required. During a resample, the water must flush through the sample ports in all sampling locations.

D.2.8.6.4 Chlorine Residual Requirements

At each sampling location, the water shall satisfy the chlorine residual requirements as follows:

Sampling Round 1:

The total chlorine residual in the sample shall be equal to the source water total chlorine residual plus or minus 0.2 mg/L; and,

The combined chlorine residual in the sample shall be equal to or greater than 0.25 mg/L or the free chlorine residual shall be equal to or greater than 0.05 mg/L.

Sampling Round 2:

The total chlorine residual in the sample shall be no more than 0.2 mg/L above the source water total chlorine residual;

The total chlorine residual in the sample shall be no less than 50% of the source water total chlorine residual from day one; and;

The combined chlorine residual in the sample shall be equal to or greater than 0.25 mg/L or the free chlorine residual shall be equal to or greater than 0.05 mg/L. The maximum allowable concentration is 50 mg/L.

Combined chlorine residual is the total chlorine residual minus the free chlorine residual.

In some rare and unique circumstances (e.g. chlorinated / chloraminated mixed areas, chlorine residuals may not be achievable. Sign off will be at the discretion of the Chief Municipal Engineer or designate.

A single failed chlorine residual parameter will constitute a failure of that entire sampling round, both chlorine residual and bacteriological and will necessitate the Contractor re-initiating Sampling Round 1 testing. The Contractor may elect to re-sample (chlorine and bacteriological) or take other corrective action to achieve two (2) consecutive rounds of acceptable chlorine residual and bacteriological results.

The chlorine readings shall be taken at the same time as the water sample for bacteriological testing is collected.

The source water chlorine residual readings, against which all sampled chlorine residual results are measured, are those chlorine residuals representative of the source water charged into the watermain for the intention of bacteriological testing. The source water chlorine readings are taken only at the beginning of the bacteriological testing protocol. If the watermain is flushed to re-initiate another bacteriological testing protocol, new source water total and free chlorine residuals readings shall be taken. The source water chlorine residual readings (total combined and free) shall be taken within four (4) hours of charging the watermain for bacteriological testing.

In the event that the source water has combined chlorine residual less than 0.25 mg/L **and** a free chlorine residual less than 0.05 mg/L, the Chief Municipal Engineer shall be notified immediately to take appropriate action.

Only licensed testing personnel as defined in Ont. Reg. 248/03 shall measure and report on total combined and free chlorine residuals. An appropriately licensed Contractor is not precluded from making chlorine residual measurements provided that the measurements are witnessed by the Contract Administrator.

D.2.8.6.5 Bacteriological Requirements

Only licensed testing personnel as defined in Ont. Reg. 248/03 shall measure and report on Bacteriological samples.

At each sampling location, the water shall satisfy the bacteriological requirements as follows both Sampling Round 1 and 2:

E. Coli	A (Presence / Absence Test)
Total Coliform	A (Presence / Absence Test)
Background	<100 (Membrane Filtration)

Bacteriological samples shall be taken as outlined on the sampling plan. A single failed bacteriological parameter will constitute a failure of that entire sampling round and will necessitate the Contractor re-initiating Sampling Round 1 testing. The Contractor may elect to re-sample (chlorine and bacteriological) or take other corrective action to achieve two (2) consecutive rounds of acceptable bacteriological results. Corrective action for a failed water sample during the 3rd round (after the final connection has been made) will be addressed by the Contract Administrator in the consultation with the Chief Municipal Engineer.

In addition to passed bacteriological tests, a copy of the pre-post chlorination report and a copy of the backflow prevention test report are required to allow for connection.

D.2.8.6.6 Laboratory Submissions

Within the Region of Waterloo, the bacteriological samples for analysis shall be accompanied by fully completed approved forms, completed by licensed testing personnel and submitted to the Regional Municipality of Waterloo Laboratory (100 Maple Grove Road, Cambridge, 650-8275 or 650-8219). Only samples submitted in bottles supplied by the laboratory will be accepted.

Within the **City of Guelph**, the laboratory will be designated and submission requirements outlined by the City of Guelph. Laboratory water samples for analysis will only be received Monday to Friday 9:00am to 1:00pm. Special arrangements may be made for after hours or weekend submissions. Contractor will be responsible for any additional costs incurred.

The Developer/ Contractor is responsible for all analytical fees including the fees related to additional samples submitted due to failed results. Additional costs associated with providing water may apply.

Water samples for analysis will only be received Monday to Thursday 8:30am to 3:30pm. Special arrangements may be made for Friday submission from 8:30am to 3:30pm but only with the prior approval of the laboratory and the Chief Municipal Engineer.

The laboratory can only release results to the Chief Municipal Engineer and will not discuss the results with the Contract Administrator or Contractor. The results are generally released to the Chief Municipal Engineer 26 to 28 hours after the water sample submission.

The Contractor may elect to use a private laboratory to undertake the bacteriological testing. The private laboratory must be accredited by the Province of Ontario to undertake the tests and shall be approved by the Chief Municipal Engineer. If the use of a private laboratory is chosen, the same laboratory must be used for all samples for the first and second rounds of testing plus any final connection samples mandated by the Municipality. The Contractor shall ensure that the appropriate relevant information is provided on the private laboratory sample submission and results form. The Municipality will not be responsible for any costs incurred due to incomplete submission forms or associated re-sampling.

D.2.8.6.7 Custody Control

The Contract Administrator or his representative and contractor must witness all chlorine residual and bacteriological sampling. All water samples shall stay under the control of the licensed tester or City staff (**Guelph only**) until the samples are delivered to the laboratory.

The laboratory results will be emailed to the Municipal Reviewer. All sampling results shall be reviewed and approved by the Municipal Reviewer before the new watermain can be approved for connection to the existing water distribution system. The Municipal Reviewer will contact the Contract Administrator who in turn will relay the information to the Contractor.

D.2.8.6.8 Post Final Connection Bacteriological Testing

Contractors are advised that the Contract Administrator and/or the Chief Municipal Engineer has the authority to request a third round of water samples for bacteriological analysis after the final connection has been made to the existing water distribution system to confirm the continued quality of the water within a period of two (2) working days. In the event that adverse water samples occur, the Chief Municipal Engineer will direct the corrective actions to be taken. The Contractor shall cooperate and participate fully in the corrective actions at the Contractors expense.

In the event, the Contractor does not take appropriate measures to correct adverse water samples and/or at the discretion of the Chief Municipal Engineer, the new system may be isolated from the municipal water system and the Contractor will be required to provide two (2) consecutive rounds of chlorine and bacteriological to the standards set out to commission the new water system.

The inspector must inform the Chief Municipal Engineer if additional testing/flushing is required upon final connection (e.g. due to possible suspected contamination or unsanitary site).

D.2.8.7 Final Connection to Existing Water System

D.2.8.7.1 Procedure

After the pressure, leakage, chlorine residual and bacteriological tests have passed; the Contractor shall obtain written approval from the Chief Municipal Engineer to make the final watermain connection to the existing watermain distribution system. Once final approval to connect is granted, the contractor is to connect to the municipal system within 5 days from approval.

If a temporary water system has been installed, it shall not be removed until after the Chief Municipal Engineer has accepted the final connection of the new watermain to the existing municipal system and has authorized the removal of the temporary water system.

The local operating authority shall be contacted two (2) full working days prior to the final connection to determine if any special measures shall be taken and/or an appropriately licensed operating authority employee is required to oversee the works. The Contractor will be responsible for all costs for call outs of Municipal staff if the Contractor fails to notify the Municipality that the connection will not take place.

The Contract Administrator shall be present to witness the entire final connection process of the new watermain to the existing water distribution systems. **Region of Waterloo and all municipalities'** representatives needs to be present during final connection.

Watermains shall be cut back to remove all temporary taps. The Contractor shall disinfect the connection watermain as outlined below and shall, using all means possible, dewater the watermains and trench in a controlled manner to not allow backflow into the watermains. Upon

final connection the contractor shall contact the municipality to flush water through a nearby municipally owned hydrant (contractor to provide a minimum 48 hour notice prior to final connection).

If trench water, dirt or debris has entered the watermain during the final connection the watermain shall be aggressively flushed and additional bacteriological samples shall be taken as directed by the Contract Administrator and/or the Chief Municipal Engineer. The Chief Municipal Engineer reserves the right to request the above steps be taken regardless.

The Contractor shall submit written procedures for completing the final connection, including the method of dewatering to ensure the existing or new water system is not contaminated.

All procedures must comply with AWWA C651-05.

D.2.8.7.2 Connections Equal To or Less Than One Pipe Length

For a final connection length equal to or less than one pipe length, the new piping, fittings and valves required for the connection shall be spray-disinfected and swabbed with a minimum 1% and maximum 5% solution of chlorine just prior to being installed. The Contractor shall ensure that the workers undertaking the disinfection process thoroughly wash their hands with soap and use hygienic practices.

D.2.8.7.3 Connections Greater Than One Pipe Length

In the event that the final connection point of the new watermain to the existing watermain distribution system is in a location that requires a connection length greater than one pipe length. The new piping, fittings and valves required for the connection shall be assembled aboveground, disinfected and tested in accordance with AWWA 651. The connection piping shall satisfy the chlorine residual and bacteriological requirements outlined for new watermains.

The pre-assembled watermain connection shall be drip tight. Only after satisfactory chlorine residual and bacteriological results have been achieved, shall the pre-assembled connection be installed. The pre-assembled watermain shall be maintained under pressure from the start of chlorine residual and bacteriological testing protocol until just prior to the installation. All caps shall be kept in place during the installation procedure until immediately prior to making the connection.

The Contractor shall not hand disinfect one pipe length at a time to circumvent the requirements to preassemble connection piping over one pipe length aboveground.

Should the Contractor find it necessary to deviate from the protocol as outlined in AWWA 651 and above, the Contractor shall submit a Connection Plan to the Chief Municipal Engineer for review and approval. The Contractor shall allow two weeks for review.

D.2.8.7.4 Tracer Wire

During the final connection of the new watermain to the existing distribution system, the Contractor shall contact the Municipality prior to making any connection to the existing tracer wire. This is to avoid the interconnection of cathodically protected watermain systems.

D.2.8.8 Tracer Wire Conductivity Test

Before the installation of the granular road subbase, the Contractor shall demonstrate the integrity of the underground tracer wire by applying a conductivity signal and confirming the signal on all watermains and services. The Contract Administrator shall witness the conductivity test(s) and provide written confirmation with the attached form provided in Part E. In the **Township of Woolwich** the Water and Wastewater Supervisor is to be notified as Township Staff must witness the test(s).

The intent of this test is to confirm that the tracer wire has been installed on all non-metallic watermains and services as specified. Specifically, the test shall demonstrate the integrity and continuity of the tracer on all watermains and services.

A continuity signal shall be applied to the tracer wire and the signal confirmed over the entire length of all tracer wire installed. The signal shall be detectable for a distance of at least 300m from either side of the signal connection point. At no time shall there be a break in the continuity of the tracer wire.

It shall be demonstrated that the tracer wire on the services is connected to the watermain tracer wire and that the service tracer wire is intact for the length of the service.

The Contractor shall demonstrate that the tracer wire in chambers can be accessed from finished grade and that the signal is detectable on the watermain outside of the chamber.

Acceptable means of undertaking the conductivity test include using traditional locating techniques and/or determining if a low voltage electrical current travels from the connection point to test points.

D.2.8.9 Valve Positioning

The Contractor shall demonstrate that all valves, main line and service, are in the final positioning as outlined in the Contract Documents or as directed by the Contract Administrator.

D.3 Sewers

This section provides direction on how sanitary and storm sewers and their associated service connections and appurtenances are to be installed, commissioned and tested to meet the technical requirements of the Contract Documents and all applicable regulations and acts.

D.3.1 Ontario Provincial Standard Specifications

The sewer works shall be installed in accordance with Ontario Provincial Standard Specification 410 & 401 except as amended or extended herein.

D.3.2 Sewer Installation

This sub-section provides direction on the sewer installation operations that the Contractor is required to perform to meet the technical requirements of the Contract Documents.

D.3.2.1 Laying Tolerance

The allowable laying tolerance for inverts from that shown on the Construction Drawings for all sizes and at any point along the entire length of a sewer is as follows:

Horizontal:	25 mm
Vertical for slope less than or equal to 1%:	5 mm
Vertical for slope greater than 1%:	10 mm

Additionally, pipes shall be installed with no visible ponding.

D.3.3 Maintenance Hole and Catchbasin Installation

This sub-section provides direction on the installation operations of maintenance holes and catchbasins that the Contractor is required to perform to meet the technical requirements of the Contract Documents.

D.3.3.1 Maintenance Hole Lid Adjustment Tolerance

Maintenance hole frames and lids shall be adjusted so that when tested with a 3 m straight edge in any direction of the surface, the gap shall not exceed 7 mm between the bottom of the straight edge and the surface of the asphalt or frame and appurtenance.

The **City of Waterloo, City of Cambridge, Township of Woolwich, Township of Wilmot,** and the **City of Kitchener** do not accept ring adjustments for maintenance hole lids.

D.3.3.2 Adjustment Unit Parging

Concrete adjustment units shall be as per OPSS 407 and OPSD 704.01. Precast adjustment units shall be laid in a full bed of mortar with successive units being joined using a sealant as recommended by the manufacturer. A minimum of one (1) adjustment unit shall be installed with a minimum height of 75 mm. A maximum of 3 adjustment units may be installed to a total height not in excess of 300 mm.

D.3.3.3 Maintenance Holes Connections

At new concrete maintenance holes, resilient connector shall be used to connect flexible pipe on both sanitary and storm sewers and services, and concrete brick and mortar used for connecting a concrete pipe to the concrete maintenance hole. Pipe shall be installed flush with the inside wall of the maintenance hole.

In situations where the ribbed (flexible) pipes are used, the contractor shall use a short length of the smooth wall PVC pipe with approved transition to the ribbed pipe. Concrete cradle for the support of the concrete pipes at the maintenance hole shall be constructed as per OPSS 407.07.13 and OPSD 708.020.

At existing maintenance holes the opening shall be cored and the connection made as per a new maintenance hole or a grout adapter connection.

Only concrete brick and appropriate mortar shall be used to fill void around concrete pipes. Clay bricks, stones and rubble shall not be used. The inside wall of the opening shall have a smooth mortar finish. Parging of brick and mortar connections shall be completed on the exterior of connections. The sanitary sewer MH connections must be watertight.

Flexible pipe with watertight adaptors shall not be parged on the outside or inside.

Resilient connectors must be used for concrete trunk sanitary sewer connections.

D.3.3.4 Maintenance Hole Benching

All maintenance holes shall be benched up to springline in sanitary sewers and $\frac{3}{4}$ of the pipe height in storm sewers regardless of the pipe size, including catchbasin maintenance holes. All benching shall slope up and away from the pipe at 8% slope. Storm sewer maintenance holes shall not be pre-benched by the manufacturer except in new development. Benching maintenance holes must be completed during construction on site.

In the **City of Waterloo** and the **City of Cambridge** all catchbasin maintenance holes regardless of outlet pipe size shall be installed with a 600 mm sump.

D.3.4 Service Connections

This sub-section provides direction on the installation of service connections that the Contractor is required to perform to meet the technical requirements of the contract specification.

D.3.4.1 Installation

Lateral service connections for sewers shall be installed in the locations specified on the drawings, in accordance with the Municipality's standard location, or as directed the Contract Administrator.

D.3.4.2 Minimum Pipe Length

Pipe for lateral service connections shall be installed in 4 metre minimum lengths with one cut off to terminate at the property line. The second last pipe shall be shortened to ensure that the last service pipe is not less than 1.2m in length.

D.3.4.3 Line and Grade

The line and grade of all lateral service connections shall be as specified on the drawings as provided by the Contract Administrator. Bends are not allowed. Sweeps at permitted. In general all sewer lateral service connections to serve private land shall be constructed at a 2% minimum and 8% maximum grade and to the following depths:

- a) For sanitary, 2.5m below finished grade at the property line unless otherwise specified
- b) For storm, 1.2 metres (2.5m **City of Guelph**) below finished grade at the property line unless otherwise specified

D.3.4.4 Mainline Connection

Service connections to the main pipe sewer shall be made using factory made tees or wyes. For infill developments strap-on-saddles or other approved saddles may be approved by the Chief Municipal Engineer. Factory-made tees or wyes shall be used for all service connections where the diameter of the main pipe sewer is:

- a) Less than 450 mm
- b) Less than twice the diameter of the service connection

D.3.4.5 Maintenance Hole Connections

Sanitary service connections to maintenance holes are permitted. All services connected to maintenance holes shall be resilient connectors. If the invert of the service entering the maintenance hole is 0.61m or more above the lowest invert, a drop pipe must be installed to direct flow to the main channel.

D.3.4.6 Caps

Watertight rubber gasket caps shall be installed in the ends of all lateral service connections. All caps shall be as specified by the pipe manufacturer to insure a watertight seal.

Plugs are not to be installed unless written approval is provided by the Chief Municipal Engineer.

D.3.4.7 Markers

The ends of lateral service connections (and the location of caps) shall be marked by extending a 38 mm x 89 mm timber marker vertically from the cap to a height of 1 metre above finished ground level. The exposed end of these marker stakes shall be painted green for sanitary and white for storm.

D.3.4.8 Connection to Existing Materials

When connecting to, or extending an existing PVC service, injection-moulded gasketed PVC coupling connections shall be used for PVC to PVC connections. Ferncos shall not be permitted on a PVC to PVC connection.

D.3.5 Commissioning

This sub-section provides information on the inspection and testing requirements and procedures to be followed by the Contractor to complete the commissioning of the sewer system.

D.3.5.1 General

In order for a sewer to be considered for acceptance by the Chief Municipal Engineer, the following procedures and tests shall be successfully completed in the presence of the Contract Administrator:

- leakage
- visual inspection
- cleaning and flushing
- deflection
- CCTV Inspections

All field tests conducted in this subsection shall be performed in the presence of the Contract Administrator. Under no circumstance swabbing shall be completed on new sewer mains prior to CCTV. This is to ensure ponding is visible during CCTV inspection.

D.3.5.2 Leakage

Leakage tests shall be carried out on all completed sewers 1200 mm in diameter and smaller as per OPSS 410. There shall be no visible infiltration for sewers with a diameter greater than 1200 mm.

D.3.5.3 Visual Inspection

The sewers, maintenance holes and all related appurtenances shall be cleaned of all foreign material either by flushing, the use of cleaning buckets, by hand or by a combination of all three.

The sewers shall be inspected by the Contract Administrator for alignment and obstructions. Ponding in gravity sewers will not be accepted.

Regardless of the results of tests as hereinafter provided, all visible or detectable leaks in sanitary and storm sewers shall be repaired by the Contractor as a prerequisite to acceptance of the sewers.

D.3.5.4 Cleaning and Flushing**D.3.5.4.1 Flushing**

Sewer sections shall be cleaned using a combination unit with a high velocity jet, approved by the Chief Municipal Engineer. Contractors may obtain water from approved Municipal filling stations only after obtaining permission from the water system operating authority. If the Municipality has allowed a fire hydrant to be used as a filling station, any damage to that, or any other, fire hydrant resulting from misuse shall be the responsibility of the Contractor.

The cleaning equipment shall have a selection of two or more high-velocity nozzles. The nozzles shall be capable of producing a scouring action in all sizes of pipe. The combination unit shall include a water tank, debris tank, suction mechanism and hydraulically driven hose reel.

Cleaning equipment shall be capable of removing dirt, grease, rocks, sand, and other materials and obstructions from the sewer lines and manholes by use of a vacuum system. The Contractor shall be required to make as many passes as necessary.

If cleaning of an entire section cannot be successfully performed from one manhole, it can be assumed an obstruction is present and cleaning efforts will cease and further investigations done.

D.3.5.4.2 Cleaning Precautions

During cleaning operations, satisfactory precautions shall be taken so that the water pressure created does not damage or cause flooding of public or private property. When possible, the flow of sewage in the sewer shall be utilized to aid in the cleaning process. In older sections of the Municipality, it may be necessary to reduce pressures to less than 7,000 kPa to prevent water damage to homes. A maximum pressure of 11,000 kPa will be used to prevent damage

to the sewer lines. The Contractor is responsible for any flooding caused by his flushing operation and must respond immediately to any complaints received.

D.3.5.4.3 Material Removal

Debris such as dirt, sand, rocks, grease and other solid or semi-solid material, which is a result of cleaning, shall be removed at the downstream manhole of the section being cleaned. The Contractor shall plug, bag and/or screen the sewer at the outlet to prevent materials from being flushed into downstream reaches. Passing material from manhole to manhole shall not be permitted due to the risk of a line plugging. This material shall be removed. At the end of each day back flush the last section of sewer cleaned to ensure no build-up of debris has occurred.

All catchbasins, double catchbasins and ditch inlets to be cleaned of all construction formed material.

D.3.5.4.4 Disposal of Material

The Contractor shall make provision to properly dispose of all debris in accordance with all provincial legislation and MECP guidelines.

D.3.5.4.5 Re-Inspection

If in the opinion of the Contract Administrator, it is determined that re-inspection is required as a result of inadequate cleaning, the Contractor shall re-clean and re-inspect the sewer at no additional cost to the Municipality.

D.3.5.5 Deflection

Deflection testing shall be carried out on all sewers constructed using plastic pipe. Each mandrel test equipment shall pass the "go-no-go rings" to ensure the mandrel equipment is in good conditions without dents, missing bars, or defects.

D.3.5.6 CCTV Inspections

D.3.5.6.1 General

Inspections shall be carried out by the Contractor after the placement of base asphalt and/or finish grading, using television cameras and video recording equipment as specified by the Municipalities requirements as set out in the contract. Where no specifications exist, OPSS 409 shall be the minimum standard used. All CCTV inspections are to be carried out by NASSCO certified operators in good standing and coding defects meeting PACP, MACP and/or LACP standards. A continuous record of the internal condition of the piping system shall be provided in digital format as specified by the Municipality. CCTV inspection shall be on the main pipe, catchbasin leads and shall include the service lateral up to the property line, except for City of Kitchener which does not require lateral CCTV for new development.

D.3.5.6.2 Acceptance

Acceptance of sewer line cleaning shall be made upon the successful completion of the **television inspection and shall be to the satisfaction of the Contract Administrator.** If

CCTV inspections show the cleaning to be unacceptable, the Contractor is required to re-clean and re-inspect the sewer until accepted by the Contract Administrator.

D.3.5.6.3 Flow Control and By-Pass Pumping

When interruptions of sewer section flows are necessary to effectively conduct inspections, the Contractor shall, subject to the approval of the Chief Municipal Engineer, control flows using plugging and blocking methods.

The Chief Municipal Engineer reserves the right, when necessary, to request bypassing and dewatering of a sewer to be inspected to ensure that the full diameter of pipe is visible.

The contractor will be responsible for any damage to public or private property resulting from the bypass operation or lack thereof. This operation may be requested when the flow depth covers the entire lens for approximately 35% of the line.

A sewer line plug shall be inserted into the line at a manhole upstream from the section to be inspected. The plug shall be designed so that all or any portion of the sewage flows can be released during the inspection. Flows shall be reduced in order to inspect the pipe invert. Sewage levels upstream of the plugged section **shall be monitored at all times**. After the work is completed, flows shall be restored to normal.

Region of Waterloo and Area Municipalities
Design guidelines and supplemental Specifications
For Municipal Services
Part E
Standard Drawings and Design Sheets

Standard Drawings and forms

Note: For municipal servicing other than storm, sanitary and watermain, refer to the applicable municipal standard drawings.

List of Drawings

NUMBER	DESCRIPTION
E1-01	Standard Bedding For Sewers and Watermains
E1-02	Maximum Pipe Sizes for Manholes
E2-01	Hydrant Installation
E2-02	Valve and Box Installation Detail (up to 300mmØ)
E2-03	Frost Collar Installation for Curb Stop Boxes Located in Driveways
E2-04	Standard Water Service Connection Detail for Metallic Services (25mmØ)
E2-05	Standard Water Service Connection Detail for Non-Metallic Services (25mm and 50mmØ)
E2-06	Water Service Connection Detail (25mm and 50mmØ Sizes)
E2-07	Water Service Connection Detail (100mmØ or Larger)
E2-08	Temporary Water Sample Port (For New Mains and Temporary Main)
E2-09	Drain and/or Swab Retrieval Chamber (for PVC and Ductile Iron Pipe)
E2-10	Drain Chamber (for Concrete Pressure Pipe)
E2-11	Vent and Drain Detail
E2-12	Air & Vacuum Release Valve Chamber
E2-13	Flushing and Swab Retrieval Outlet (up to 300mm Ø)

NUMBER	DESCRIPTION
E2-15	Anode Installation and Wire Connections
E2-16	Typical CPP Shop Drawing Minimum Detail Required
E2-17	Typical Water Connection Schematic
E2-18	Tracer Wire Access Port for Transmission and Raw Watermains
E4-02	Catchbasin with Slotted Drain
E4-03	Side Inlet Catchbasin
E4-041	Side Inlet Catchbasin Frame and Cover Detail
E4-042	Side Inlet Catchbasin Cover (Fish Pattern)
E4-05	Internal Grate for Concrete Pipe
E4-06	Rodent Grate for Attachment to Outlet
E4-07	Precast Concrete Catch Basin for Curb Inlet Overflow 600x840mm
E4-08	Precast Concrete Twin Inlet Flat cap for Curb Inlet Overflow 1500mm diameter
List of Design Sheets	
E-DS1	Hydrostatic Pressure Test Template
E-DS2	Tracer Wire Conductivity Test Template
E-T1	Watermain Commissioning Plan
E-T2	Chlorine Residual Maintenance Plan
E-T3	Groundwater Protection for Construction Projects within 200m of a Municipal Supply Well
E-T4	Standard Practices for Construction Work within 200m of a Municipal Supply Well

NOMINAL PIPE INSIDE DIAMETER D (mm)	MINIMUM TRENCH WIDTH W (mm)	MINIMUM BEDDING BELOW d (mm)	MINIMUM COVER OVER PIPE C (mm)
RIGID PIPE			
900 or less	O.D. + 600	150	300
greater than 900 to less than 2100	O.D. + 600	0.15 x I.D.	300
2100 & over	O.D. + 1000	300	300
FLEXIBLE PIPE			
Under 1200	O.D. + 600	150	300

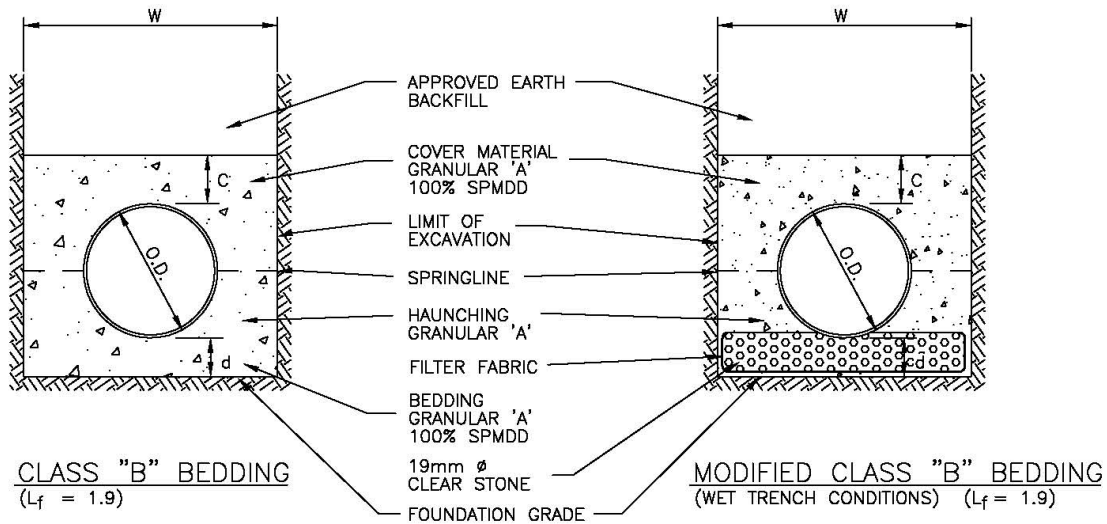

**BEDDING FOR RIGID AND FLEXIBLE
PIPE SEWERS**

NOTES:

- O.D. = OUTSIDE DIAMETER OF PIPE.
- I.D. = INSIDE DIAMETER OF PIPE.
- IN ROCK TRENCHES, BEDDING DEPTH (d) BELOW WATERMANS AND SEWER PIPES SHALL BE INCREASED TO 300mm.
- FOR PURPOSE OF CONTRACT SPECIFICATIONS BEDDING INCLUDES BEDDING HAUNCHING & COVER MATERIAL.
- IN WET TRENCH CONDITIONS 19mm Ø CLEAR STONE MAY BE USED TO INVERT OF PIPE. THE BEDDING BELOW INVERT SHALL BE WRAPPED IN FILTER FABRIC (TERRAFIX 270 R OR APPROVED EQUAL) WHERE DIRECTED BY THE ENGINEER.
- GRANULAR "A" BEDDING SHALL NOT CONTAIN RECYCLED ASPHALT

REGION OF WATERLOO AND AREA MUNICIPALITIES STANDARD DRAWINGS

REVISION DATE: JAN. 2021

**STANDARD BEDDING FOR
SEWERS AND WATERMANS**

SSMS

E1 - 01

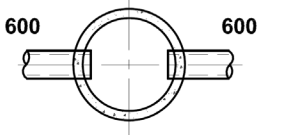
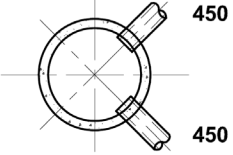
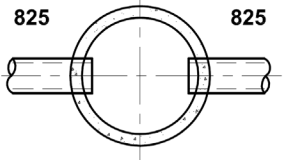
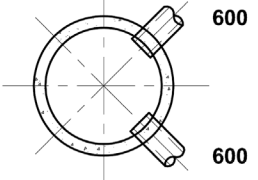
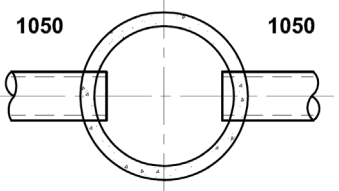
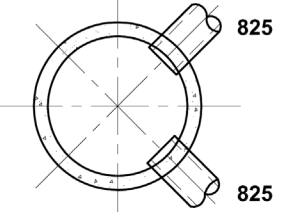
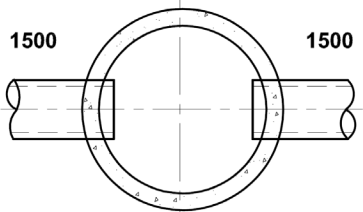
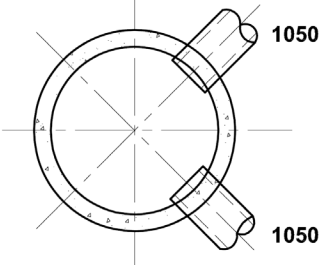
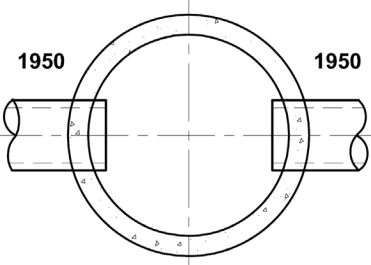
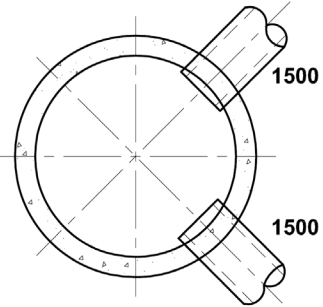
Maintenance Hole Inside Diameter (mm)	Max. Pipe Size for Straight Through Installation (mm)	Max. Pipe Size for Right Angle Installation (mm)	Remarks
1200			<p>ALL DIMENSIONS ARE FOR CONCRETE PIPE</p> <p>KNOCKOUTS FOR SMALL DIAMETER LATERALS (i.e. 250mm or 300mm) COULD BE PROVIDED IN ADDITION TO WHAT IS SHOWN</p>
1500			
1800			
2400			
3000			
REGION OF WATERLOO AND AREA MUNICIPALITIES STANDARD DRAWINGS			REVISION DATE: FEB. 2008
<h2>MAXIMUM PIPE SIZES FOR MANHOLES</h2>			<h1>SSMS</h1>
			<h2>E1 - 02</h2>

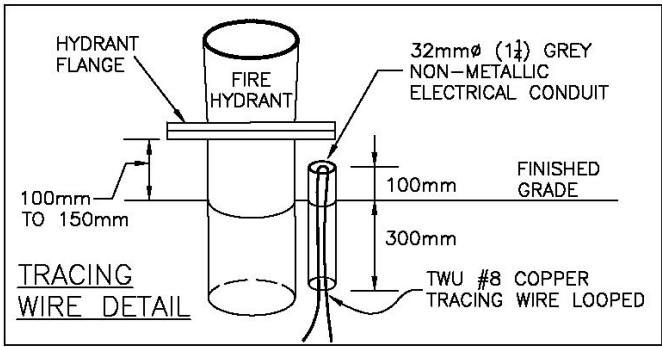
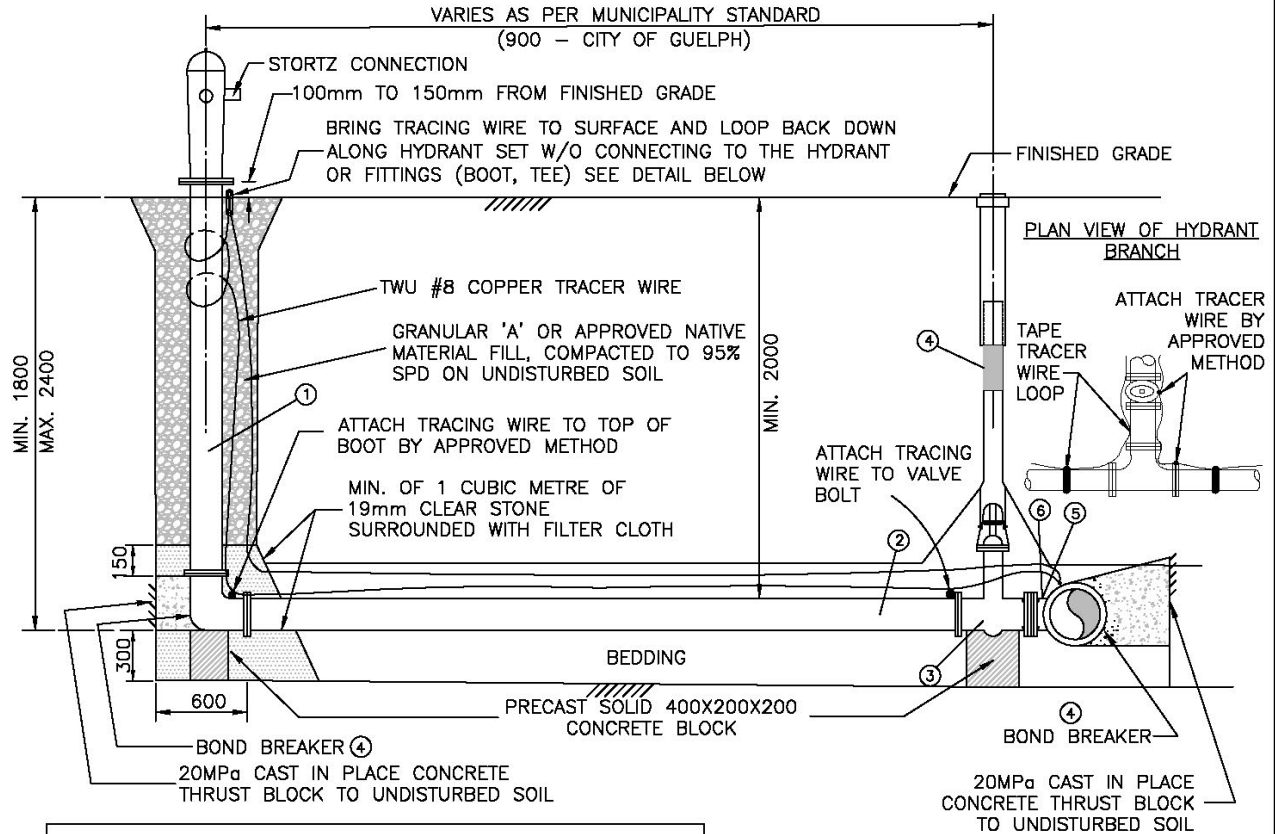

MANUFACTURED ITEMS LIST

- ① REGULAR 150mm ϕ BARREL, USE EXTENSION IF REQUIRED.
- ② MINIMUM DIA. PIPE FOR HYDRANT LEADS TO BE 150mm ϕ .
- ③ MINIMUM SIZE M.J. GATE VALVE TO BE 150mm ϕ .
- ④ VALVE BOX
- ⑤ USE ANCHOR TEE UP TO AND INCLUDING 450mm ϕ (EXCEPT IN GUELPH).
- ⑥ ALL TEES, USE MECHANICAL RESTRAINTS.

NOTES:

1. HYDRANT TO BE SET PLUMB WITH STEM EXTENSIONS TO SUIT DEPTH OF BRANCH. BRANCH TO BE SET LEVEL. EXTENSIONS TO BE INSTALLED BETWEEN UPPER AND LOWER BARREL SECTION. ONLY ONE EXTENSION (MAX. 1.0m LONG PER HYDRANT. IF MORE HEIGHT IS REQUIRED, THEN A LONGER BARREL SHALL BE USED.
2. ALL BLOCKING TO BE AGAINST UNDISTURBED TRENCH WALL.
3. ALL DIMENSIONS ARE IN MILLIMETERS UNLESS OTHERWISE SPECIFIED.
4. BOND BREAKER TO BE USED BETWEEN CONCRETE AND FITTINGS.
5. CORROSION PROTECTION SHALL BE AFFIXED AS PER STANDARD SPECIFICATIONS FOR WATERMAIN CONSTRUCTION.
6. NO FITTINGS, SLEEVES OR BENDS TO BE USED ON HYDRANT LEADS UNLESS APPROVED.
7. ALL BELL AND SPIGOT JOINTS TO BE FULLY RESTRAINED FROM HYDRANT BOOT TO TEE.
8. PLUG DRAIN HOLE IN HIGH WATER TABLE.
9. HYDRANTS SHALL BE CLEAR OF OBSTRUCTIONS FOR A DISTANCE OF 0.6m REAR, 2.0m ON SIDES AND CLEAR TO CURB IN FRONT.
10. SEE DRAWING 203 FOR CITY OF KITCHENER HYDRANT INSTALLATION.
11. SEE SECTION D.2.5.10 FOR WRAPPING PETROLATUM SYSTEM.
12. THE TRACING WIRE SHALL NOT BE CONNECTED TO ANY FITTINGS OR ANODES (FUNCTION AS A CORROSION PROTECTION SYSTEM) WITHIN THE CITIES OF GUELPH AND WATERLOO.

REGION OF WATERLOO AND AREA MUNICIPALITIES STANDARD DRAWINGS

REVISION DATE: JAN. 2020

HYDRANT INSTALLATION

SSMS

E2 - 01

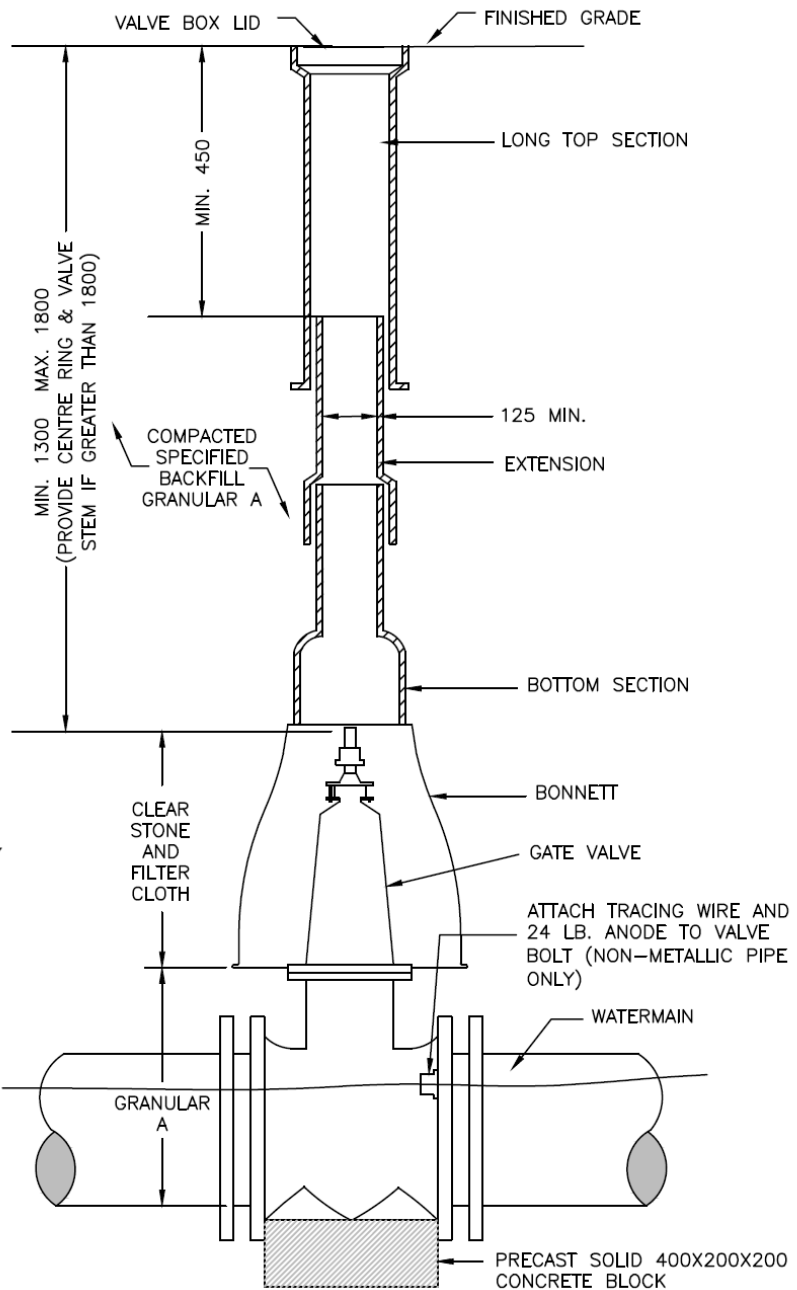

NOTES:

1. PROVIDE SCREW TYPE BOX AND EXTENSION.
2. ALL DIMENSIONS ARE IN MILLIMETERS UNLESS OTHERWISE SPECIFIED.
3. INSTALL BOX PLUMB OVER OPERATOR.
4. VALVE BOX EXTENSION TO BE USED ONLY IF REQUIRED.
5. CORROSION PROTECTION SHALL BE AFFIXED AS PER SSMS STANDARD SPECIFICATIONS FOR WATERMAIN CONSTRUCTION.
6. TRACER WIRE TO SURFACE IF SPECIFIED BY THE MUNICIPALITY AS PER D.2.6.2.
7. PETROLATUM TAPE SEE SECTION D.2.5.10.
8. SEE SECTION D.2.6.
9. THE TRACING WIRE SHALL NOT BE CONNECTED TO ANY FITTINGS OR ANODES (FUNCTION AS A CORROSION PROTECTION SYSTEM) WITHIN THE CITIES OF GUELPH AND WATERLOO.
10. Z-24-48 ANODE TO BE INSTALLED AT SIMILAR ELAVATIONS AS WATERMAIN IN NATIVE SOIL PER THE CONSTRUCTION DRAWINGS AND ATTACHED TO METALLIC VALVES/ FITTINGS WHEREVER POSSIBLE (100m. MAX. SPACING)
11. VALVE GUIDE PLATE TO BE REMOVED BEFORE INSTALLATION

REGION OF WATERLOO AND AREA MUNICIPALITIES STANDARD DRAWINGS

REVISION DATE: DEC. 2022

**VALVE AND BOX INSTALLATION DETAIL
(UP TO 300mm DIAMETER)**

SSMS

E2 - 02

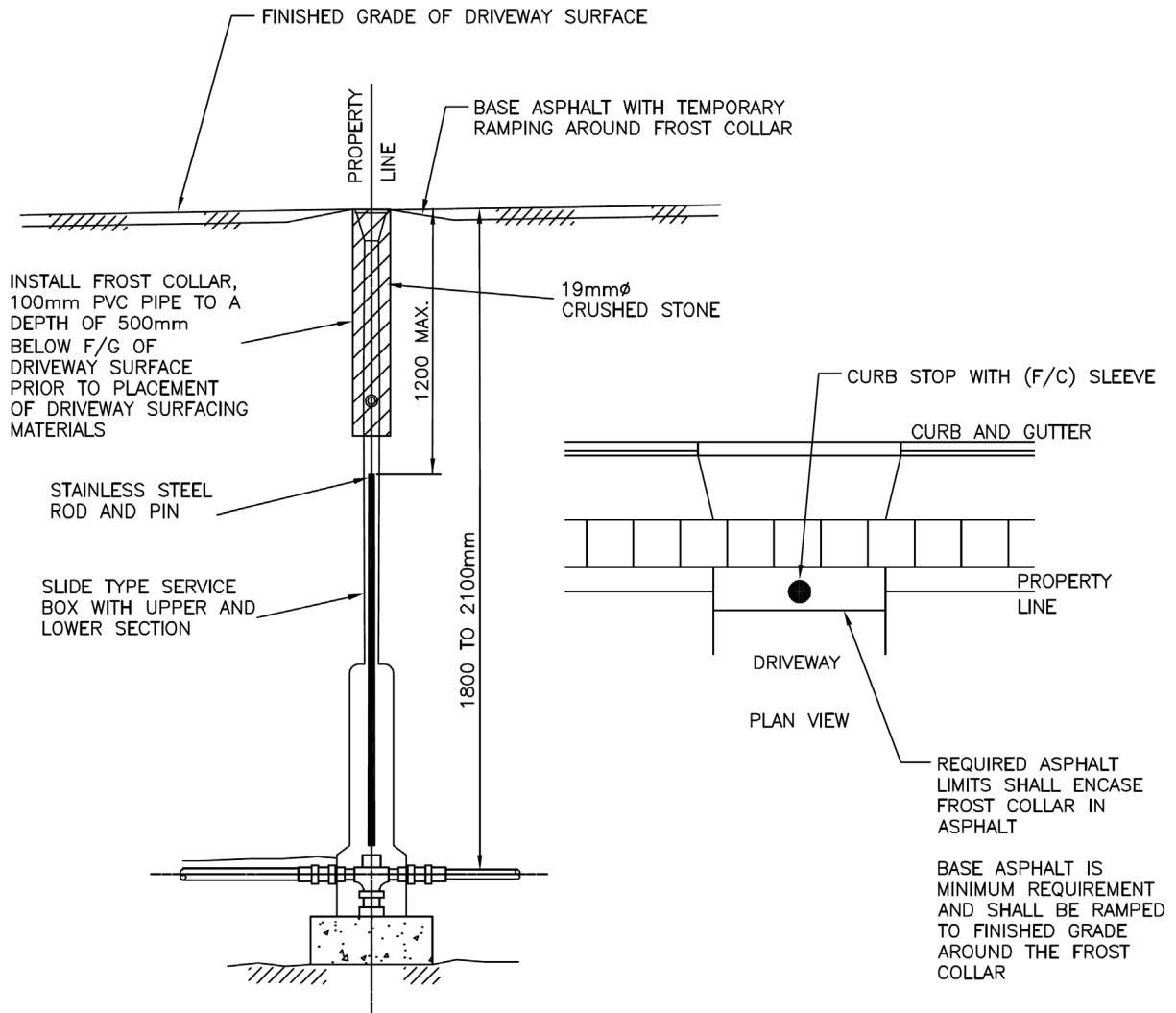

PROFILE VIEW

NOTES:

1. ALL DIMENSIONS ARE IN MILLIMETERS UNLESS OTHERWISE SHOWN.
2. FROST COLLAR TO BE ENCASED IN ASPHALT FOR APPROVAL AND REFUND OF CURB STOP DEPOSIT.
3. TOP OF FROST COLLAR SLEEVE TO BE SET AT THE ELEVATION OF FINISHED SURFACE.
4. IF ONLY PLACING THE BASE COAT OF ASPHALT, THE ASPHALT SHALL BE RAMPED AROUND THE SLEEVE UP TO FINISHED GRADE TO PREVENT DAMAGE TO THE SLEEVE.
5. ASPHALT RAMPING NOT REQUIRED WHEN DRIVEWAY IS FULLY COMPLETED TO FINISHED GRADE WITH SURFACE ASPHALT.
6. CURB STOPS ARE TO BE SET ON PROPERTY LINE AND IN LANDSCAPED AREAS WHENEVER POSSIBLE.

REGION OF WATERLOO AND AREA MUNICIPALITIES STANDARD DRAWINGS

DATE: JAN. 2016

FROST COLLAR INSTALLATION FOR CURB STOP BOXES LOCATED IN DRIVEWAYS

SSMS

E2-03

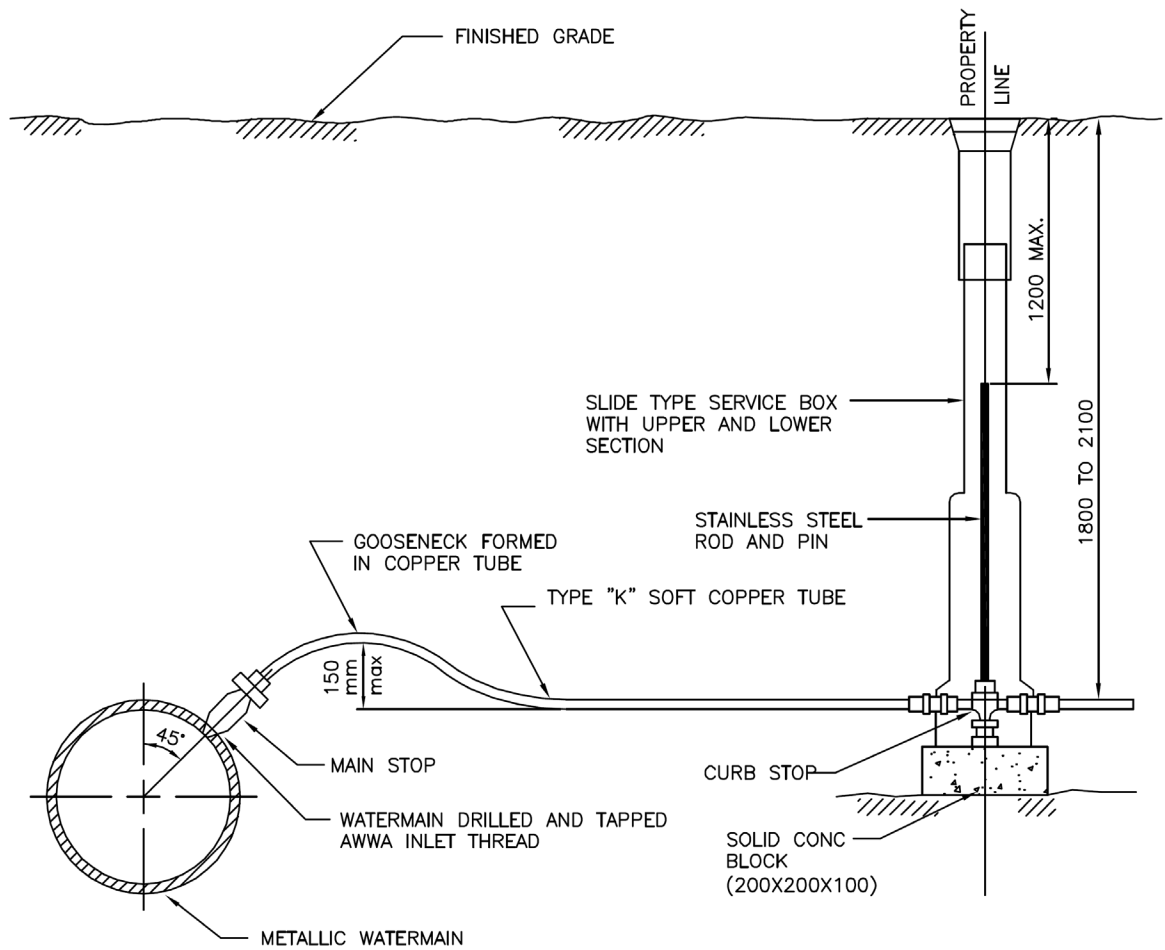

NOTES:

1. UNION COUPLINGS WILL NOT BE PERMITTED UNLESS THE SERVICE LENGTH EXCEEDS 20M AND UNIONS SHALL NOT BE PLACED UNDERNEATH ROADWAYS.
2. ALL WATER SERVICES TO BE INSTALLED 90° TO THE LONGITUDINAL AXIS OF THE WATERMAIN.
3. ALL DIMENSIONS ARE IN MILLIMETERS UNLESS OTHERWISE SHOWN.
4. CORROSION PROTECTION SHALL BE AFFIXED AS PER SSMS STANDARD SPECIFICATIONS FOR WATERMAIN CONSTRUCTION.

REGION OF WATERLOO AND AREA MUNICIPALITIES STANDARD DRAWINGS

REVISION DATE: JAN. 2016

**METALLIC WATER SERVICE CONNECTION
DETAIL FOR METALLIC WATERMAIN
25mm DIAMETER SIZES**

SSMS

E2 - 04

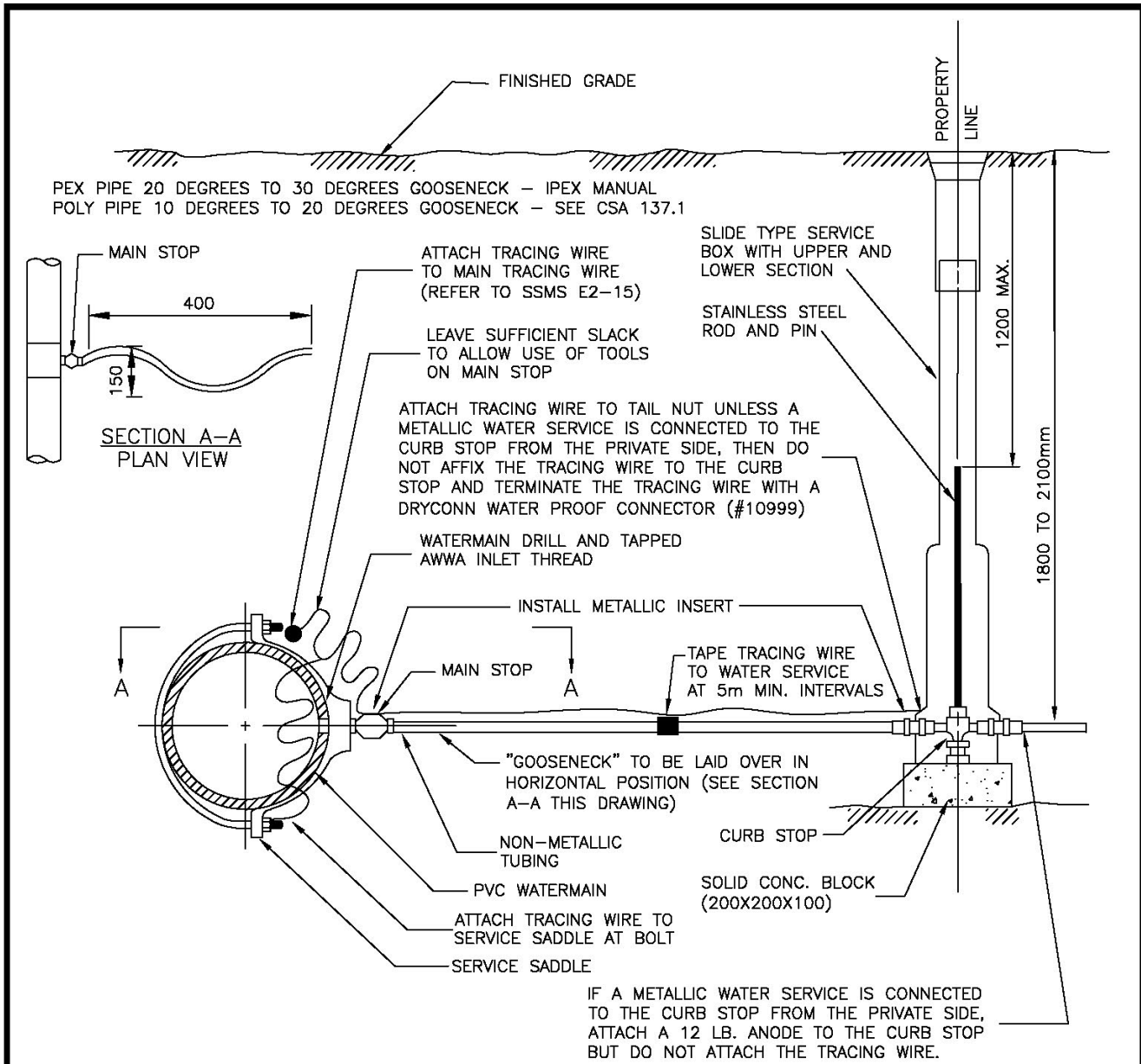

NOTES:

1. CONNECTIONS TO PLASTIC MAINS TO BE MADE USING SERVICE SADDLES OR FACTORY MADE TEES.
2. UNION COUPLINGS WILL NOT BE PERMITTED UNLESS THE SERVICE LENGTH EXCEEDS 20M AND UNIONS SHALL NOT BE PLACED UNDERNEATH ROADWAYS.
3. ALL WATER SERVICES GOOSENECK TO BE INSTALLED AS PER MANUFACTURER'S SPECIFICATIONS.
4. ALL DIMENSIONS ARE IN MILLIMETERS UNLESS OTHERWISE SHOWN.
5. CORROSION PROTECTION SHALL BE AFFIXED AS PER SSMS STANDARD SPECIFICATIONS FOR WATERMAIN CONSTRUCTION.
6. THE TRACING WIRE IS TO BE CONNECTED AT THREE LOCATIONS: THE MAIN TRACING WIRE, THE SADDLE/MAIN STOP (AT BOLT) AND THE CURB STOP (AT TAIL NUT). IF A PRIVATE SIDE METALLIC WATER SERVICE IS CONNECTED TO THE CURB STOP, THEN A 12 LB. ANODE IS TO BE ATTACHED TO THE CURB STOP BUT THE TRACING WIRE IS NOT TO BE AFFIXED TO THE CURB STOP. INSTEAD, IT IS TO BE TERMINATED USING A DRYCONN WATER PROOF CONNECTOR (#10999).
7. SEE CKSD 1104.010 FOR CITY OF KITCHENER NON-METALLIC WATER SERVICE INSTALLATION.

REGION OF WATERLOO AND AREA MUNICIPALITIES STANDARD DRAWINGS	REVISION DATE: JAN 2020
NON-METALLIC WATER SERVICE CONNECTION DETAIL FOR NON-METALLIC WATERMAIN 25mm AND 50mm DIAMETER SIZES	SSMS
	E2 - 05

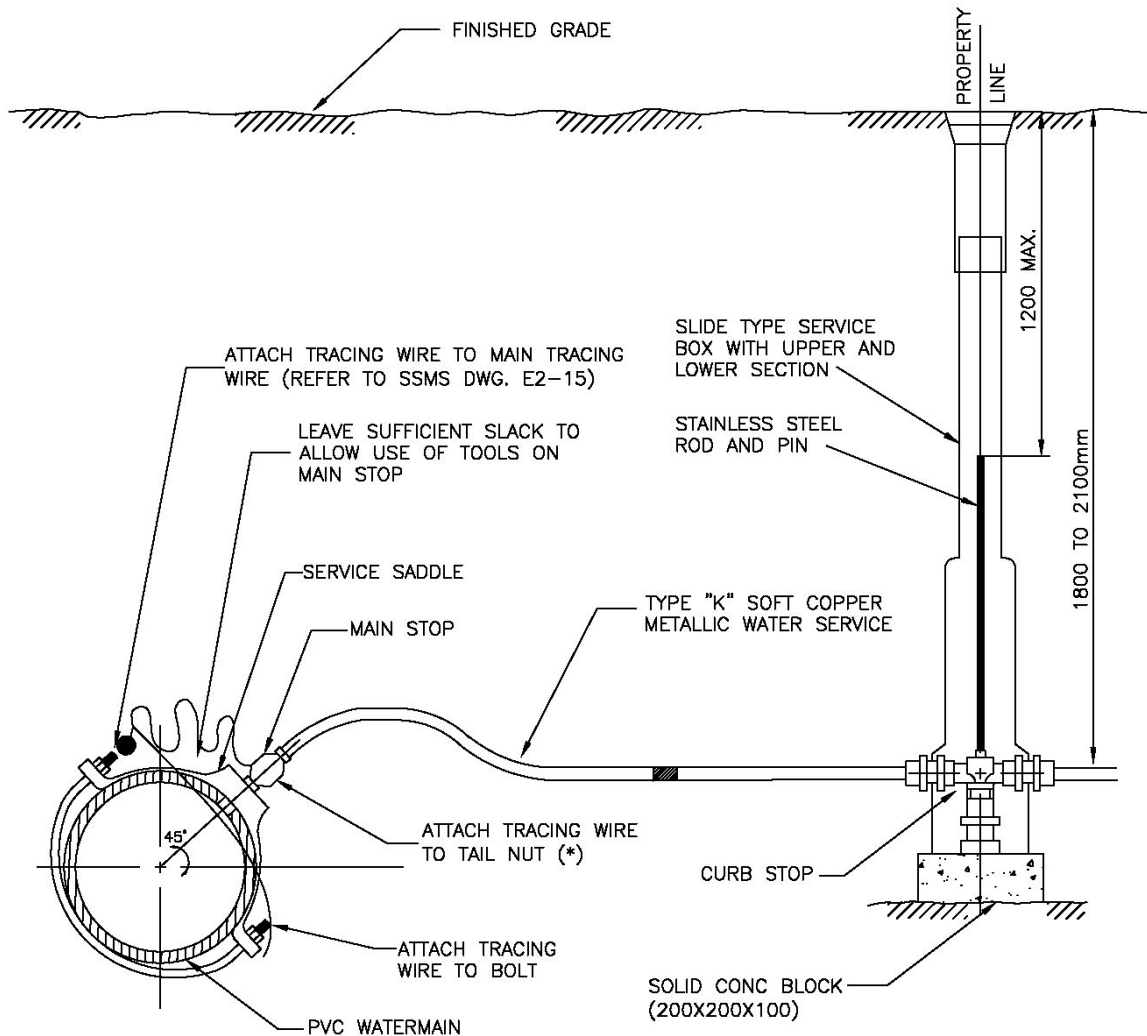

NOTES:

1. ANY JUNCTION MADE IN SERVICE PIPE BETWEEN MAIN STOP AND CURB STOP TO BE MADE WITH APPROVED COUPLINGS.
2. ALL WATER SERVICES TO BE INSTALLED 90° TO THE LONGITUDINAL AXIS OF THE WATERMAIN.
3. ALL DIMENSIONS ARE IN MILLIMETERS UNLESS OTHERWISE SHOWN.
4. CORROSION PROTECTION SHALL BE AFFIXED AS PER SSMS STANDARD SPECIFICATIONS FOR WATERMAIN CONSTRUCTION.
5. THE TRACING IS TO BE CONNECTED AT THREE LOCATIONS: THE MAIN TRACING WIRE, THE SADDLE/MAIN STOP (AT BOLT) AND THE CURB STOP (AT TAIL NUT). AN INSULATOR, SUCH AS A LENGTH OF APPROVED PLASTIC WATER SERVICE PIPE IS REQUIRED TO BE INSTALLED BETWEEN THE CURB STOP AND METALLIC SERVICE ON THE PRIVATE SIDE IN ORDER TO SEPARATE THE SYSTEMS. A MINIMUM 12 LB. ANODE IS TO BE ATTACHED TO THE PRIVATE SIDE METALLIC SERVICE.
6. THE TRACING WIRE SHALL NOT BE CONNECTED TO ANY FITTINGS OR ANODES (FUNCTION AS A CORROSION PROTECTION SYSTEM) WITHIN THE CITIES OF GUELPH AND WATERLOO.

REGION OF WATERLOO AND AREA MUNICIPALITIES STANDARD DRAWINGS

REVISION DATE: JAN. 2020

**METALLIC WATER SERVICE CONNECTION
DETAIL FOR NON-METALLIC WATERMAIN
25mm AND 50mm DIAMETER SIZES**

SSMS

E2 - 06

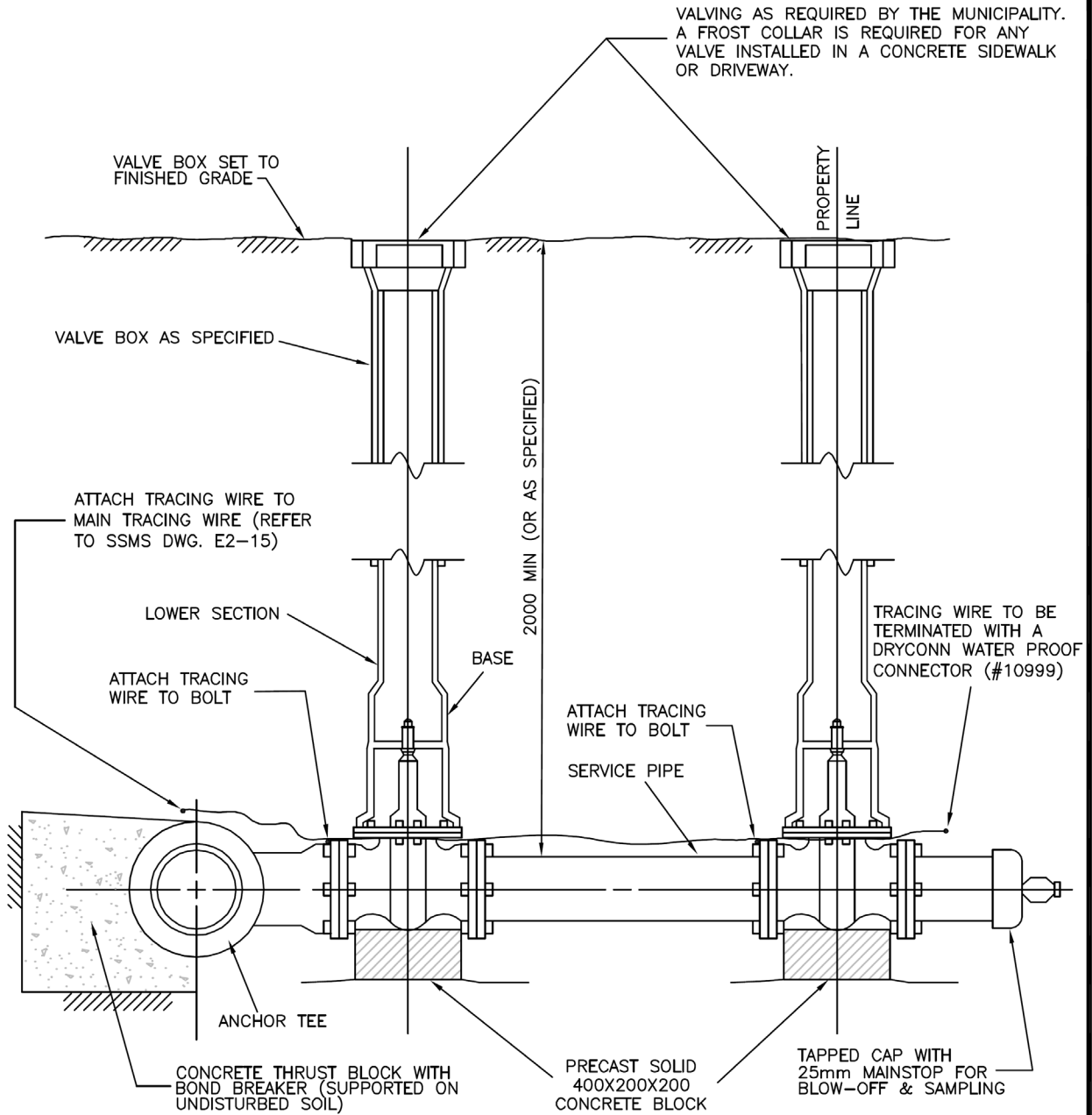

NOTES:

1. ALL DIMENSIONS ARE IN MILLIMETRES UNLESS OTHERWISE SPECIFIED.
2. CONCRETE STRENGTH TO BE NOT LESS THAN 20MPa FOR THRUST BLOCKS.
3. FULLY RESTRAIN FROM WATERMAIN TO VALVE & BOX AT PROPERTY LINE.
4. ALL TEES, USE MECHANICAL RESTRAINTS. VALVE TO BE INSTALLED WITHIN 1m IN DISTANCE FROM MAIN.
5. THE TRACING WIRE IS TO BE CONNECTED AT THREE LOCATIONS: THE MAIN TRACING WIRE, THE VALVE BOX (AT BOLT) AND THE VALVE BOX (AT BOLT PROPERTY LINE).
6. THE TRACING WIRE SHALL NOT BE CONNECTED TO ANY FITTINGS OR ANODES (FUNCTION AS A CORROSION PROTECTION SYSTEM) WITHIN THE CITIES OF GUELPH AND WATERLOO.

REGION OF WATERLOO AND AREA MUNICIPALITIES STANDARD DRAWINGS

REVISION DATE: JAN.2016

**NON-METALLIC WATER SERVICE
CONNECTION DETAIL
100mm OR LARGER**

SSMS

E2 - 07

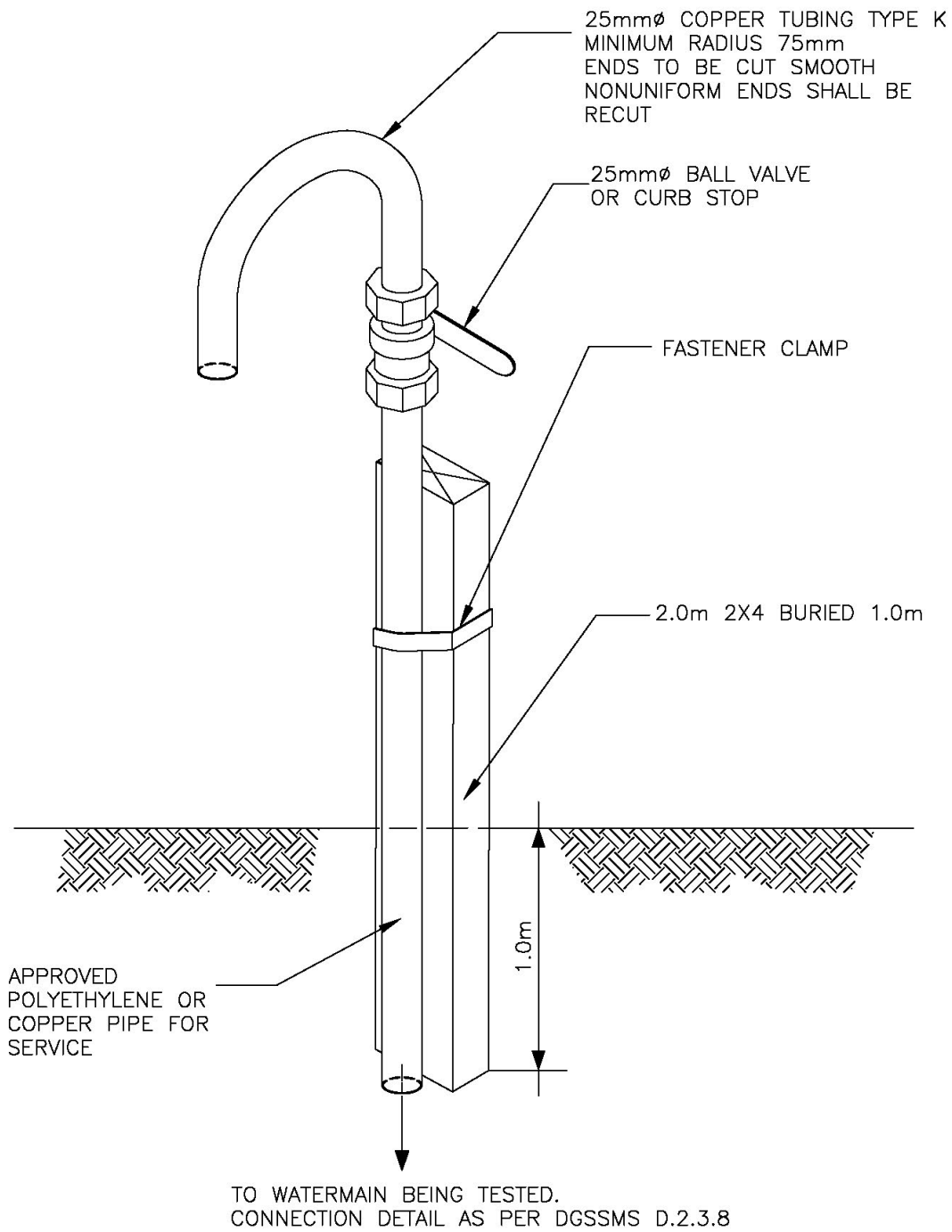

REGION OF WATERLOO AND AREA MUNICIPALITIES STANDARD DRAWINGS

DATE: JAN. 2020

**TEMPORARY WATER SAMPLE PORT
(FOR NEW MAINS and TEMPORARY MAIN)**

SSMS

E2-08

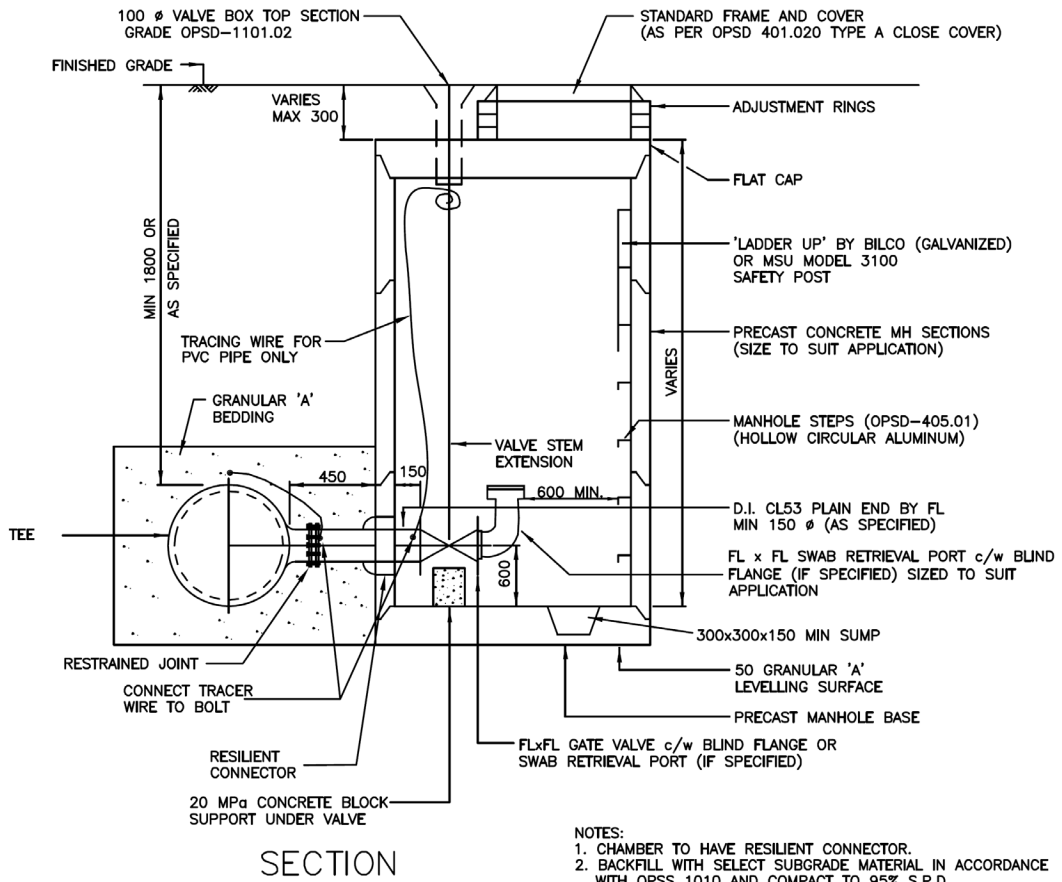
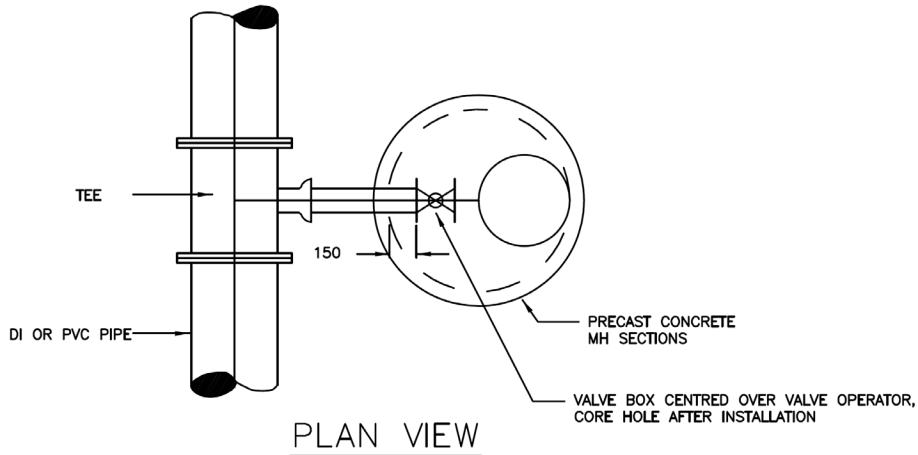

- NOTES:
1. CHAMBER TO HAVE RESILIENT CONNECTOR.
 2. BACKFILL WITH SELECT SUBGRADE MATERIAL IN ACCORDANCE WITH OPSS 1010 AND COMPACT TO 95% S.P.D.
 3. ALL JOINTS AND LIFTING HOLES TO BE SEALED WITH NON-SHRINK GROUT, INSIDE AND OUTSIDE.
 4. ALL DIMENSIONS ARE IN MILLIMETERS UNLESS OTHERWISE SPECIFIED.
 5. ALL JOINTS TO BE FULLY RESTRAINED.
 6. FOR DRAIN CHAMBER USE ONLY A 1200mmØ CHAMBER AND 150mmØ VALVE.

REGION OF WATERLOO AND AREA MUNICIPALITIES STANDARD DRAWINGS

REVISION DATE: JAN. 2013

**DRAIN AND/OR SWAB RETRIEVAL CHAMBER
(FOR PVC AND DUCTILE IRON PIPE)**

SSMS

E2 - 09

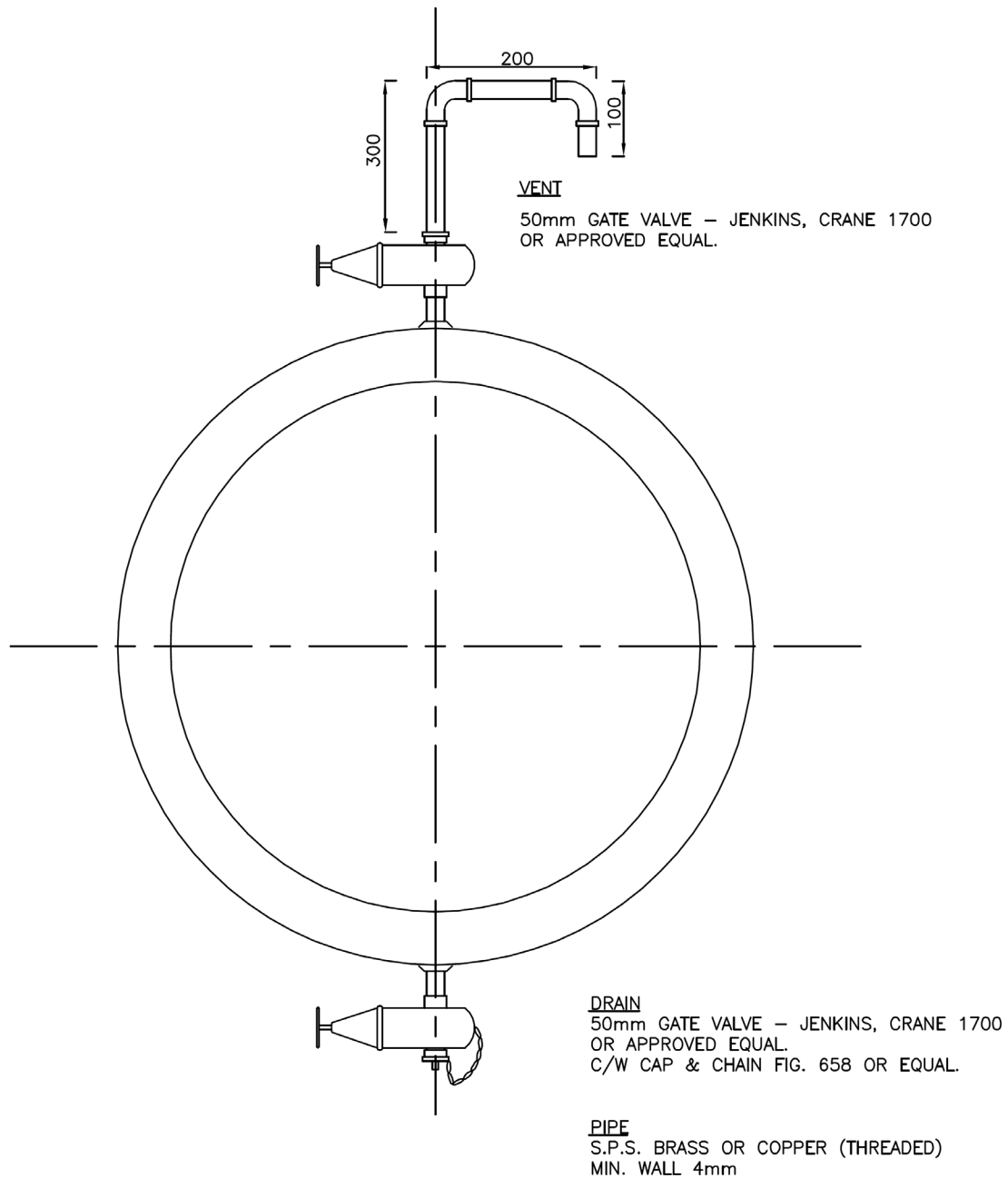

NOTES:
1. ALL DIMENSIONS ARE IN MILLIMETRES UNLESS
OTHERWISE SPECIFIED.

REGION OF WATERLOO AND AREA MUNICIPALITIES STANDARD DRAWINGS

REVISION DATE: FEB. 2008

VENT AND DRAIN DETAIL

SSMS

E2 - 11

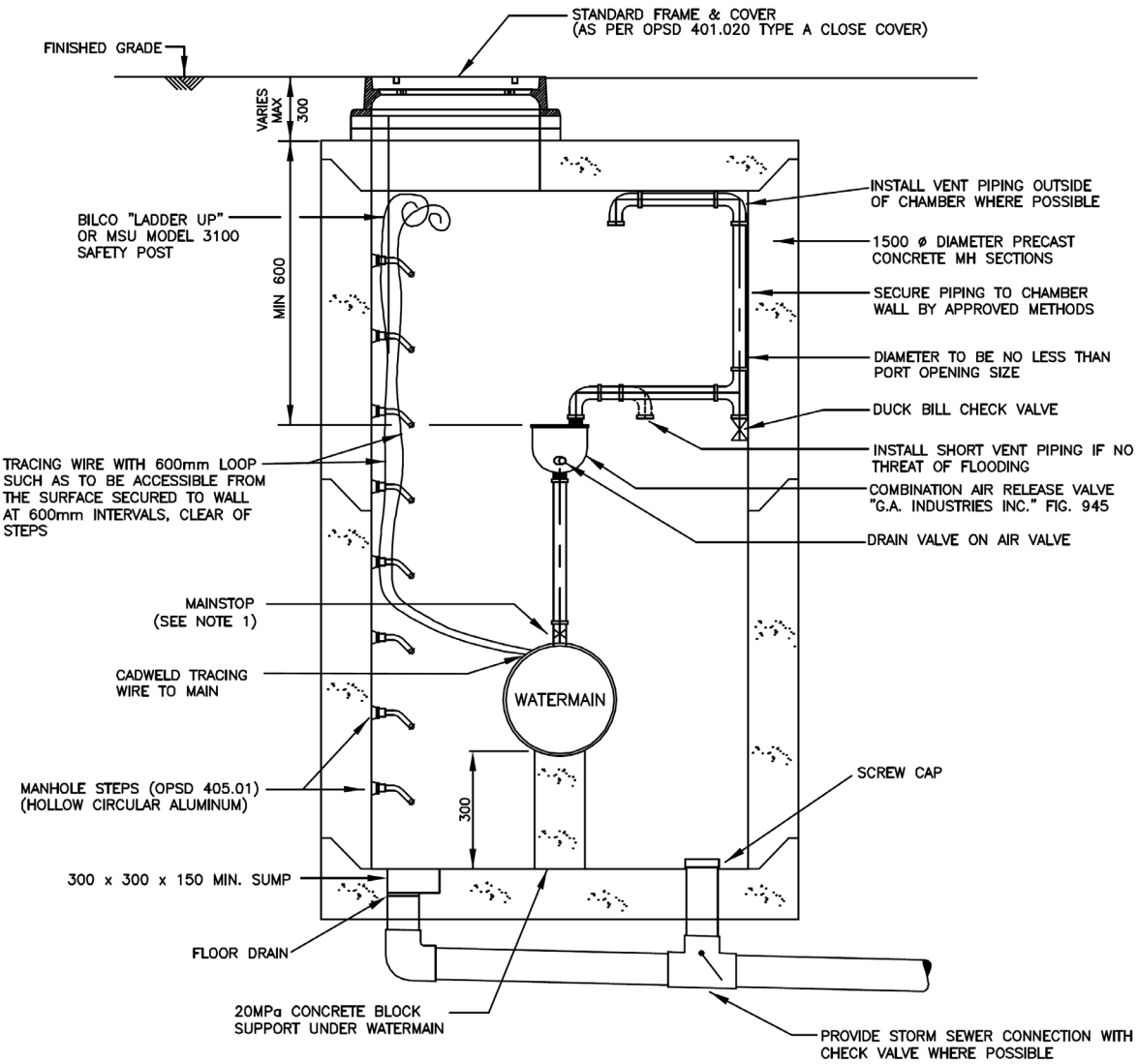

SECTION

- NOTES:**
1. AIR RELEASE VALVE & PIPING SHALL BE DESIGNED AND SEALED BY A PROFESSIONAL ENGINEER.
 2. PIPING AND FITTINGS SHALL BE THREADED COPPER OR BRASS.
 3. REINFORCED PRECAST CONCRETE MH SECTIONS SHALL BE IN ACCORDANCE WITH OPSS 407 & 1351, AND OPD 701.04.
 4. BACKFILL WITH SELECT SUBGRADE MATERIAL IN ACCORDANCE WITH OPSS 1010 COMPACTED TO 95% SPD.
 5. ALL DIMENSIONS ARE IN MILLIMETRES UNLESS OTHERWISE SPECIFIED.
 6. VENT PIPING SHALL BE SCHEDULE 40 PLASTIC.
 7. METALLIC PIPING TO HAVE PETROLATUM TAPE SYSTEM APPLIED.
 8. VENTING PIPE TO BE DESIGNED OUTSIDE OF CHAMBER WHERE POSSIBLE.

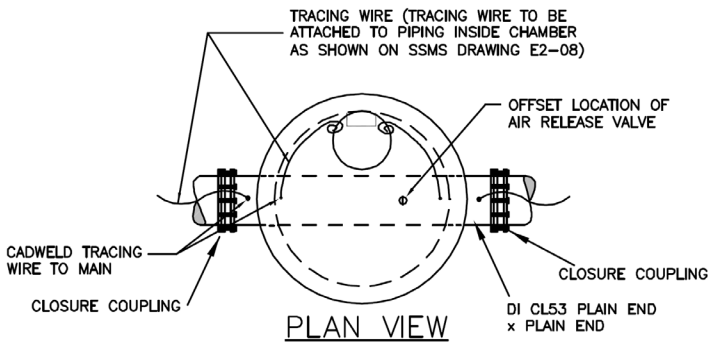

PLAN VIEW

REGION OF WATERLOO AND AREA MUNICIPALITIES STANDARD DRAWINGS	REVISION DATE: JAN. 2016
AIR & VACUUM RELEASE VALVE CHAMBER	SSMS
	E2 - 12

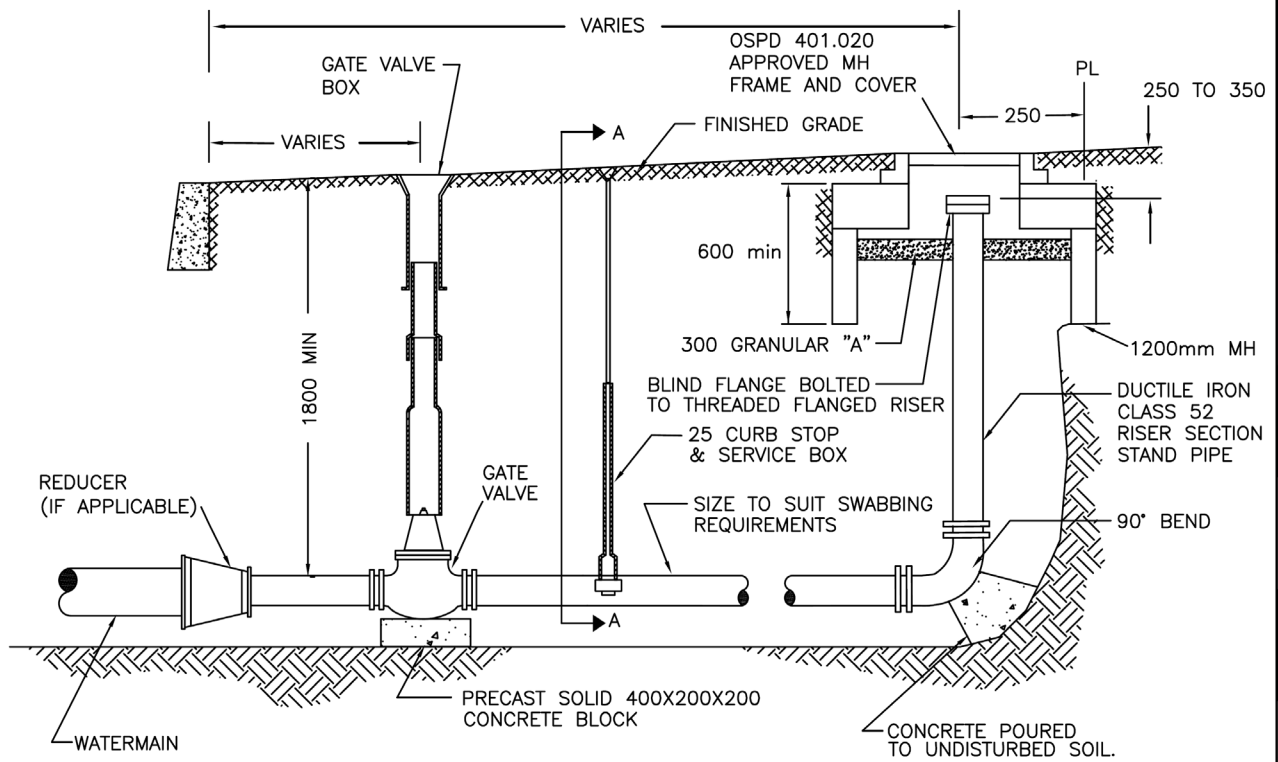

ELEVATION

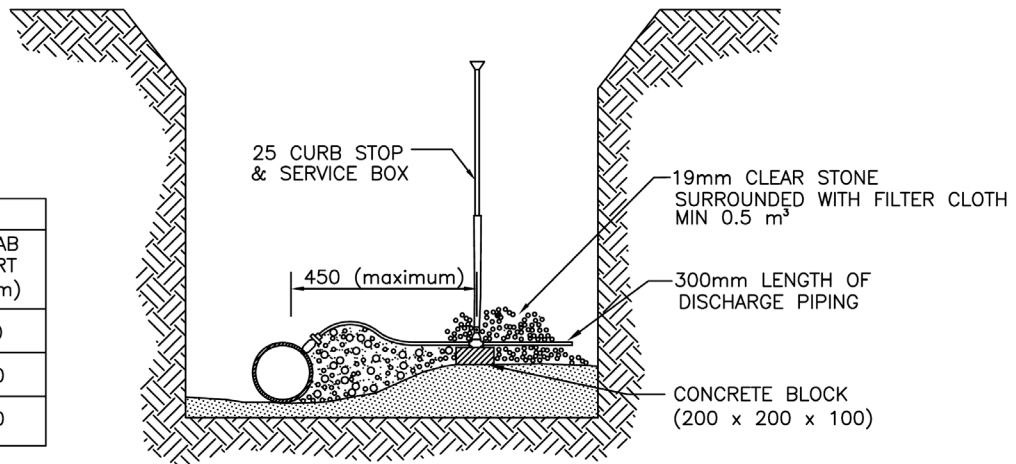

SIZES	
MAINLINE PIPE (mm)	SWAB PORT (mm)
300	150
400	200
450-600	300

SECTION A-A

NOTES:

1. ALL DIMENSIONS ARE IN MILLIMETERS UNLESS OTHERWISE SPECIFIED.
2. CORROSION PROTECTION SHALL BE AFFIXED AS PER STANDARD SPECIFICATIONS FOR WATERMAIN CONSTRUCTION TO EACH COMPONENT OF THE FLUSHING OUTLET.
3. ALL JOINTS TO BE MECHANICALLY RESTRAINED.

Z-24-48 ANODE TO BE INSTALLED AT SIMILAR ELEVATIONS AS WATERMAIN IN NATIVE SOIL PER THE CONSTRUCTION DRAWINGS AND ATTACHED TO METALLIC VALVES/FITTINGS WHEREVER POSSIBLE (100m. MAX. SPACING)

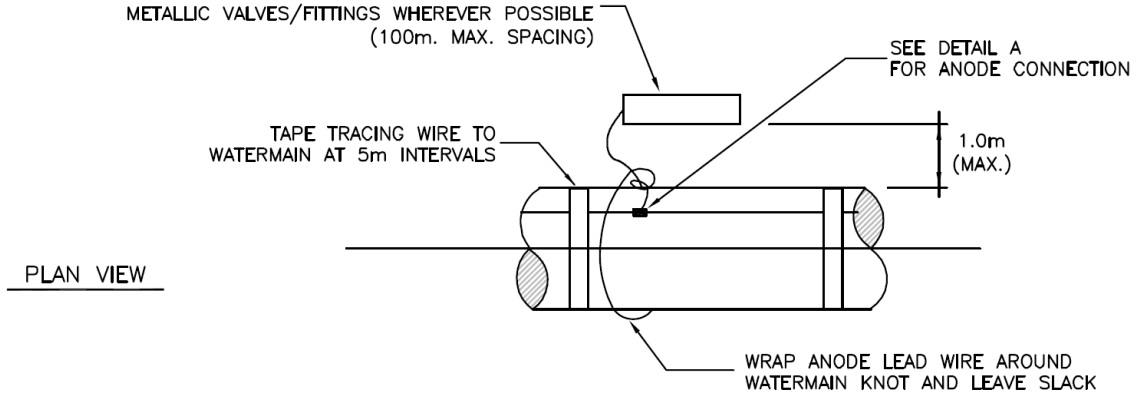

PLAN VIEW

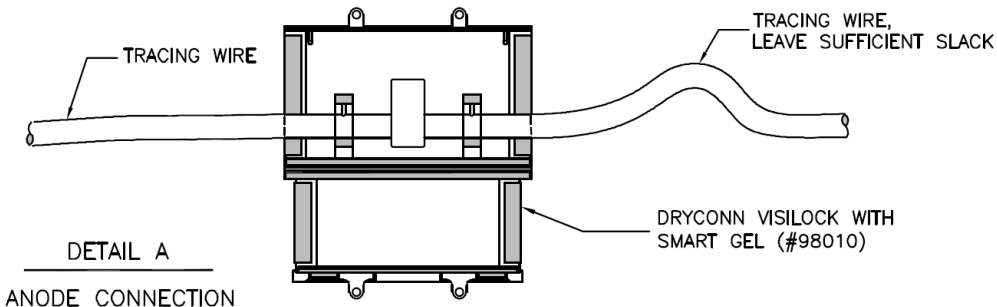

DETAIL A
ANODE CONNECTION

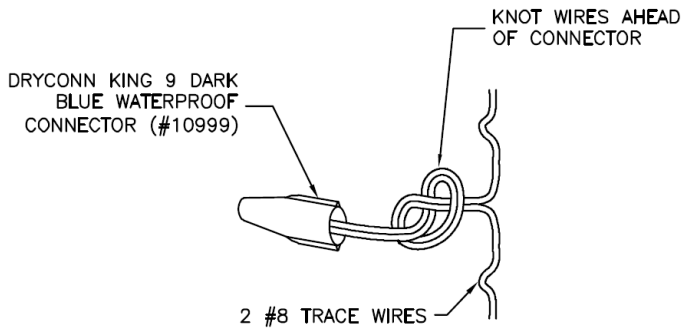

DETAIL B
TWISTED CONNECTION

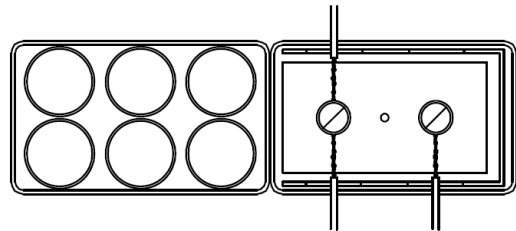

DETAIL C
3 WIRE CONNECTION DETAIL

NOTES;

1. ANODES TO BE INSTALLED HORIZONTALLY BESIDE WATERMAIN TO ONE SIDE OR THE OTHER AND PLACED IN NATIVE SOIL.
2. INSTALL DRYCONN CONNECTOR PER MANUFACTURING RECOMMENDATIONS.
3. BRASS SPLIT BOLTS MAY BE USED FOR TRACER WIRE CONNECTION AND WRAPPED.

REGION OF WATERLOO AND AREA MUNICIPALITIES STANDARD DRAWINGS

REVISION DATE: FEB. 2019

**ANODE INSTALLATION AND
WIRE CONNECTIONS**

SSMS

E2 - 15

DIRECTION OF LAY

PIPE DIAMETER AND CLASS

STREET NAME OR LOCATION

VALVE CHAMBER No
& CHAINAGE

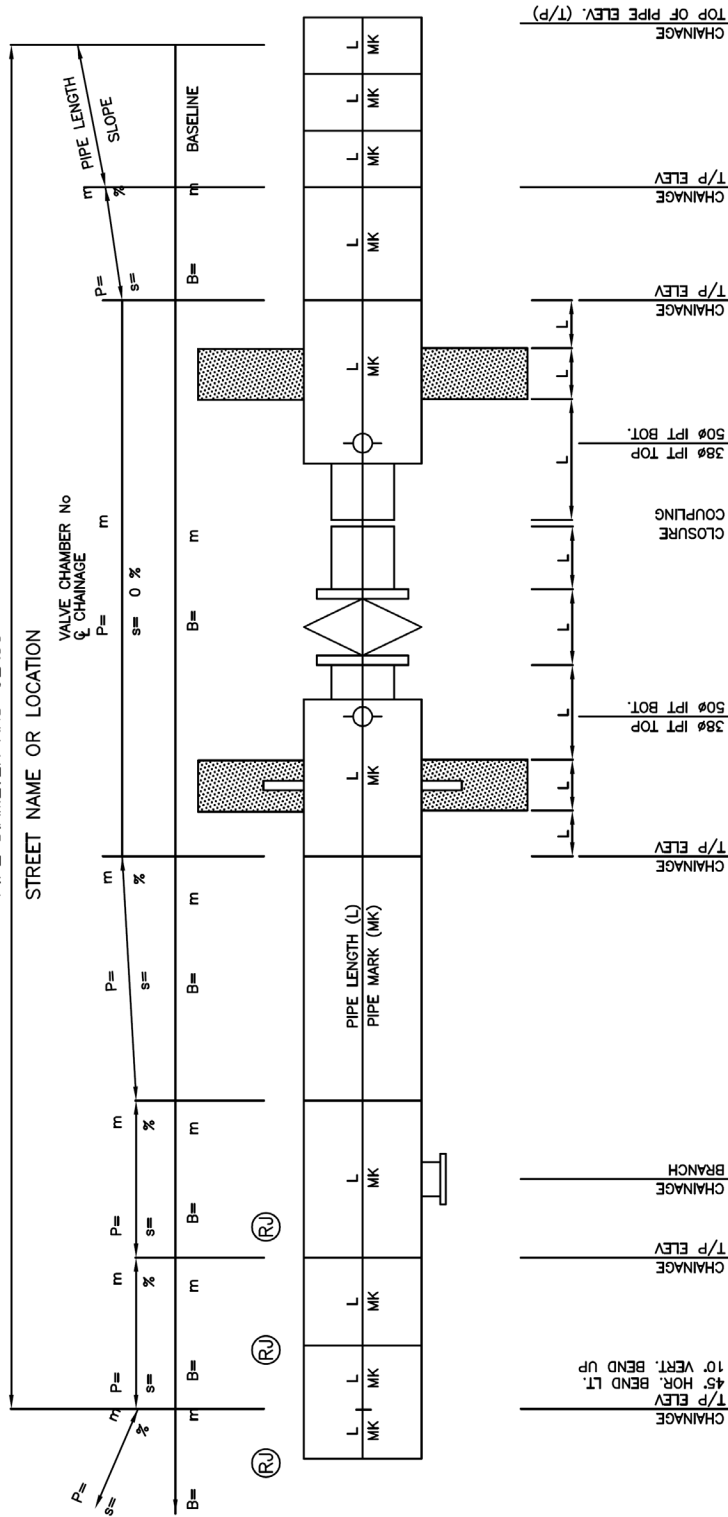

NOTES:

1. PIPE LENGTH (P) = SLOPE LENGTH ALONG C/L OF PIPE.
2. BASELINE LENGTH (B) = HORIZONTAL DISTANCE OVER C/L OF PIPE.
3. (R) = RESTRAINED JOINT.
4. IPT = IRON PIPE THREAD.

REGION OF WATERLOO AND AREA MUNICIPALITIES STANDARD DRAWINGS

REVISION DATE: FEB. 2008

**TYPICAL CPP SHOP DRAWING
MINIMUM DETAIL REQUIRED**

SSMS

E2 - 16

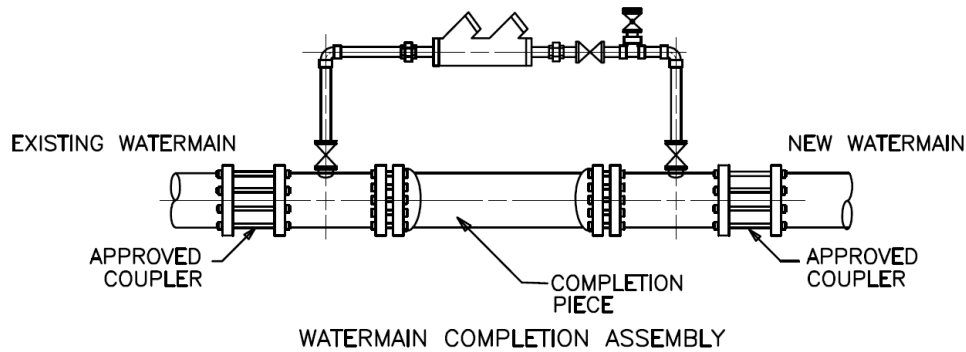
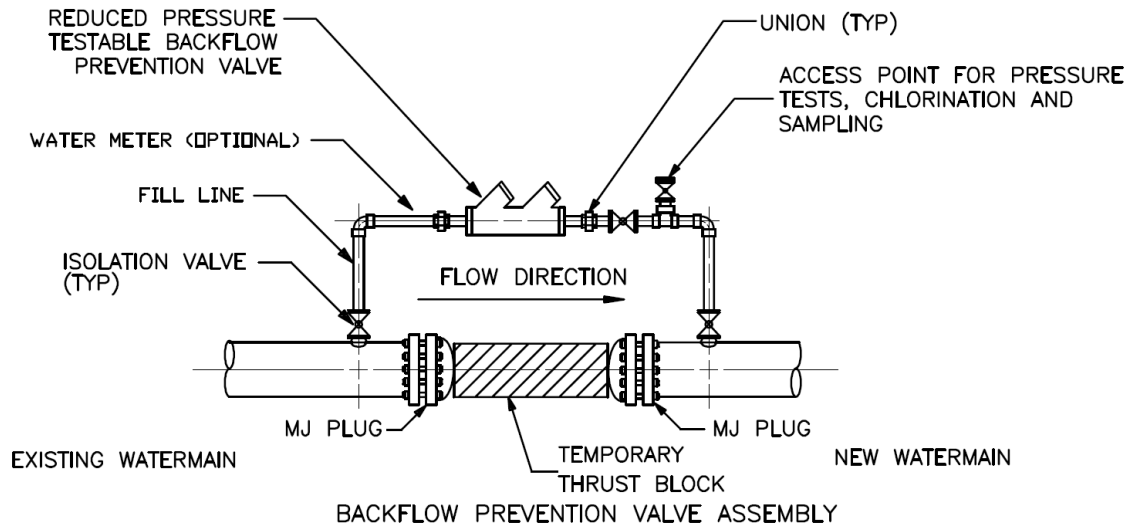

NOTES:

1. THE BACKFLOW PREVENTION VALVE ASSEMBLY SHALL BE REMOVED DURING WATERMAIN PRESSURE TESTS.
2. THE FINAL CONNECTION OF THE WATERMAIN SHALL BE COMPLETED ONLY AFTER AUTHORIZATION BY THE MUNICIPALITY.
3. THE WATERMAIN SHALL BE DRAINED BY CONTROLLED MEANS. SUFFICIENT TRENCH DEWATERING CAPACITY SHALL BE USED WHEN THE EXISTING AND NEW WATERMANS ARE DRAINED PRIOR TO THE FINAL CONNECTION TO ENSURE NO BACKFLOW INTO EITHER WATERMAIN.
4. THE WATERMAIN SHALL BE CUT BACK TO REMOVE THE TAPPING POINTS OF THE BACKFLOW PREVENTION VALVE ASSEMBLY.
5. ALL NEW PIPING AND APPURTENANCES PLACED IN THE CONNECTION SHALL BE THOROUGHLY DISINFECTED WITH 1% SOLUTION OF SODIUM HYPOCHLORITE OR EQUIVALENT.
6. ON NON-METALIC WATERMANS, THE TRACING WIRE SHALL BE CONNECTED TO THE COUPLER ONLY IF THE COUPLER IS NOT IN CONTACT WITH A METALIC WATERMAIN OTHERWISE TERMINATE TRACER WIRE WITH AN ANODE.
7. A PHYSICAL SEPARATION MUST BE MAINTAINED AT ALL CONNECTION POINTS OF NEW WATERMANS TO THE EXISTING SYSTEMS UNTIL BACTERIOLOGICAL TESTS HAVE PASSED. A SAMPLING TAP MUST BE PROVIDED AT THE END OF EACH BRANCH OR STUB.
8. ONLY MUNICIPAL STAFF SHALL OPERATE MUNICIPALITY OWNED VALVES.
9. THIS DETAIL IS FOR SCHEMATIC INFORMATION ONLY. THE ACTUAL CONFIGURATION USED MUST SATISFY THE INTENT OF THIS DRAWING.

REGION OF WATERLOO AND AREA MUNICIPAL STANDARD DRAWINGS

REVISION DATE: JAN. 2021

TYPICAL WATER CONNECTION

SSMS

E2 - 17

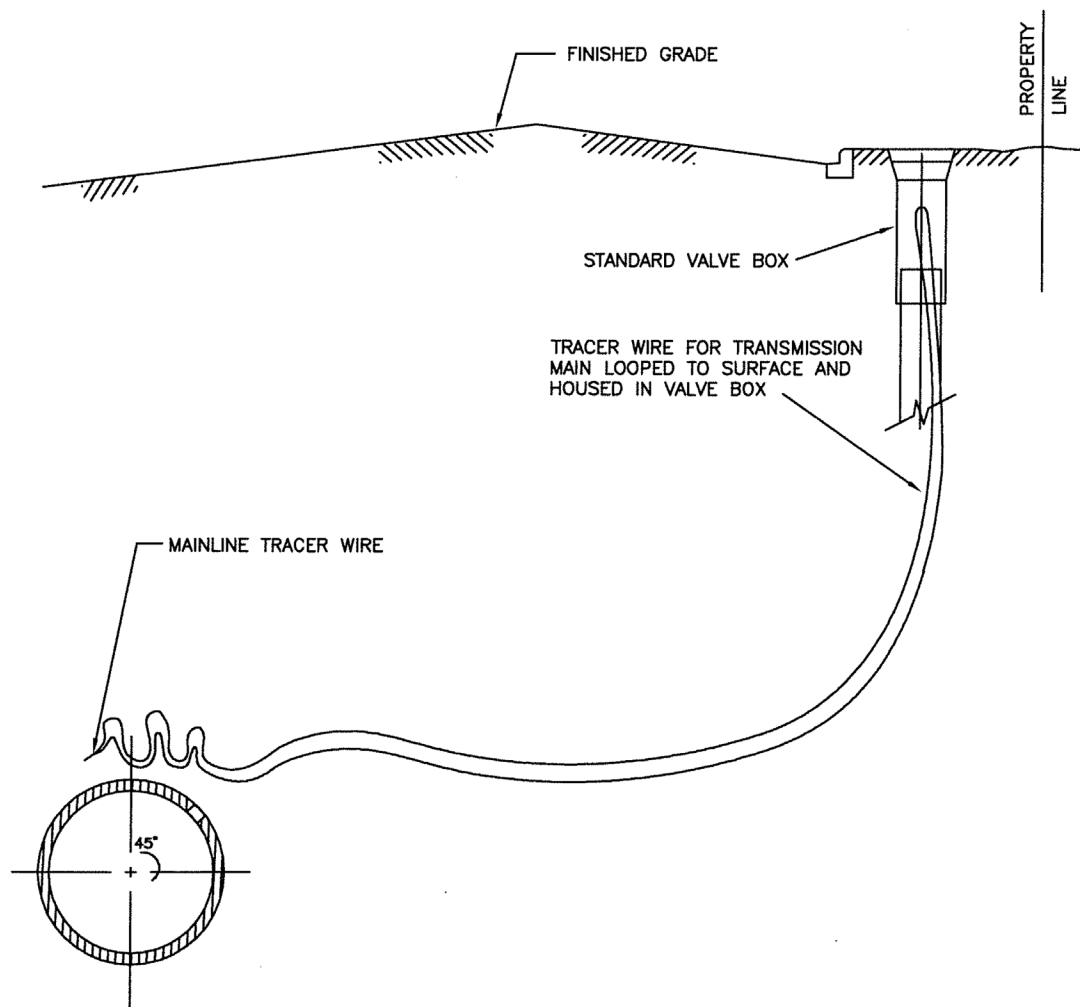

NOTE:
VALVE BOX TO BE SET TO FINISH GRADE IN BOULEVARD.

REGION OF WATERLOO AND AREA MUNICIPALITIES STANDARD DRAWINGS

DATE: JAN. 2018

**TRACER WIRE ACCESS PORT FOR
TRANSMISSION AND RAW WATERMAINS**

SSMS

E2 - 18

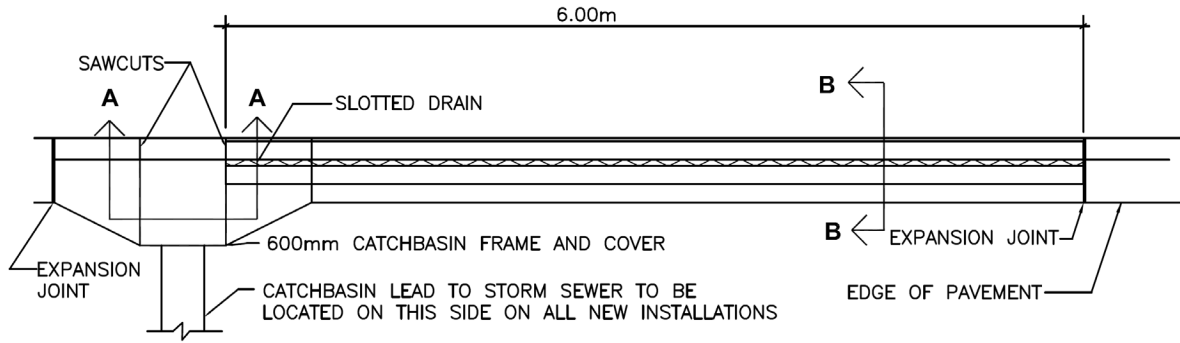

PLAN VIEW

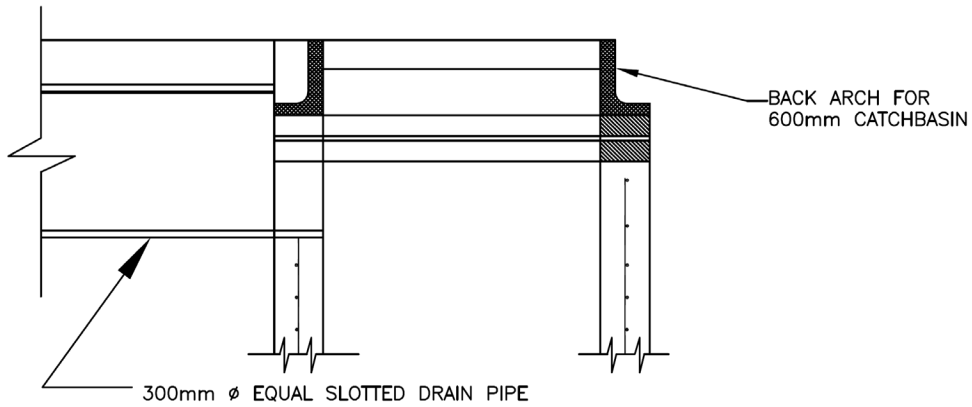

SECTION A - A

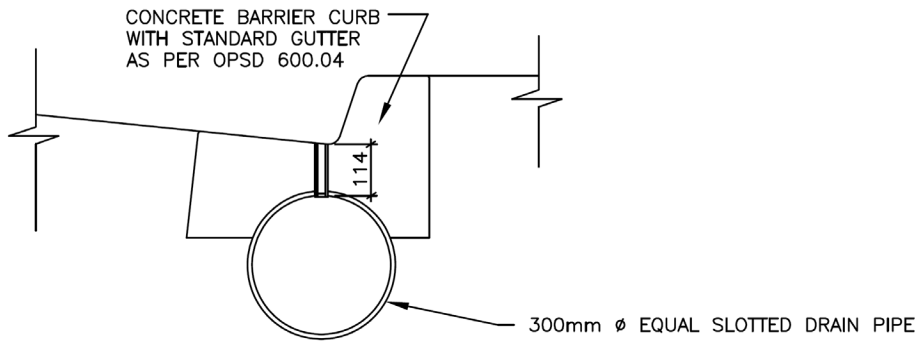

SECTION B - B

REGION OF WATERLOO AND AREA MUNICIPALITIES STANDARD DRAWINGS

REVISION DATE: FEB. 2008

CATCHBASIN WITH SLOTTED DRAIN

SSMS

E4 - 02

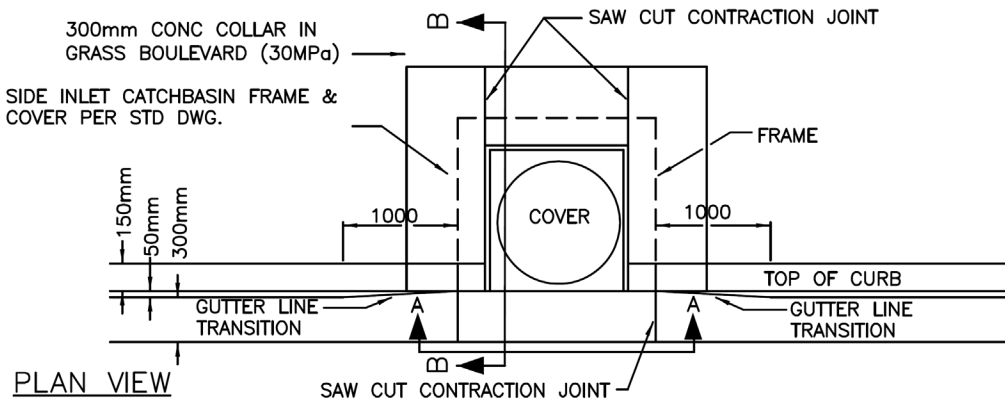

PLAN VIEW

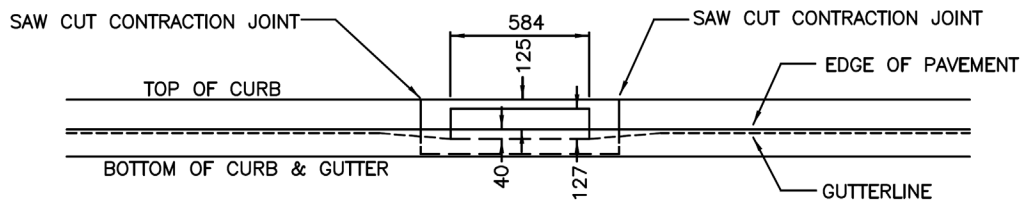

SECTION 'A-A'

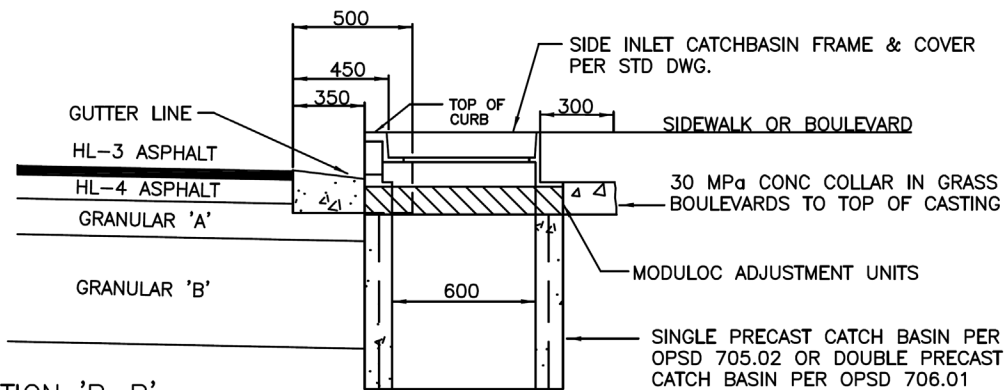

SECTION 'B-B'

NOTE:

1. ALL DIMENSIONS ARE IN MILLIMETRES UNLESS OTHERWISE SPECIFIED.
2. AT DOUBLE CATCH BASINS MAINTAIN 100mm SEPERATION BETWEEN FRAMES AND FILL WITH CONCRETE.
3. IN GRASS BOULEVARD AREAS ONLY, INSTALL 300mm WIDE CONCRETE (30MPa) COLLAR AS SUPPORT.
4. FOR TEMPORARY CONDITION PRIOR TO PLACEMENT OF SURFACE ASPHALT REFER TO RMW STANDARD DWG. 215.

REGION OF WATERLOO AND AREA MUNICIPALITIES STANDARD DRAWINGS

REVISION DATE: JAN. 2010

SIDE INLET CATCHBASIN

SSMS

E4 - 03

REFER TO
DETAIL #1

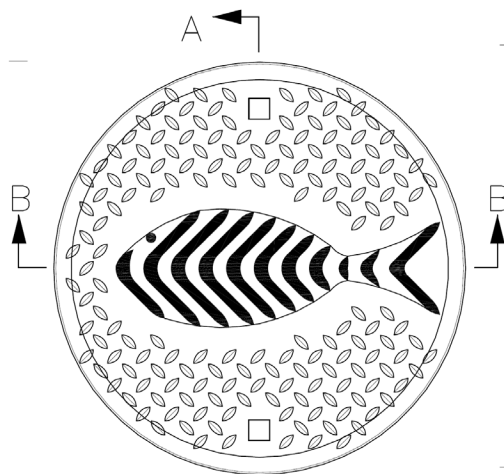

— 25 X 25
LIFT HOLE

A

PLAN

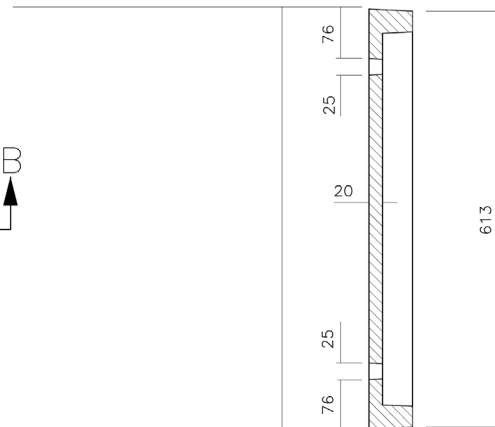

SECTION A-A

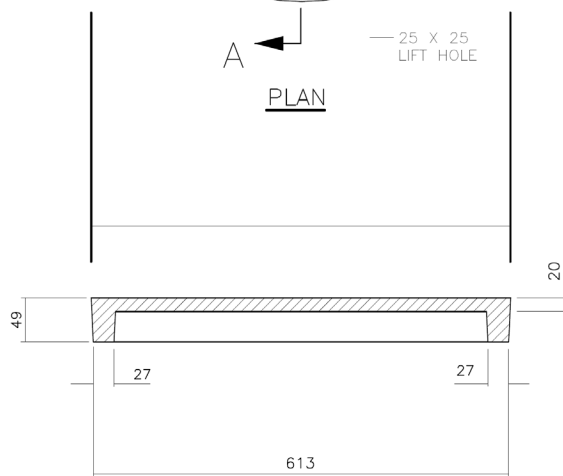

SECTION B-B

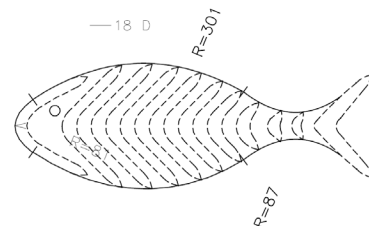

DETAIL #1

NOTES:

1. ALL DIMENSIONS SHOWN ARE FOR FINISHED CASTINGS ONLY.
PATTERN MARKERS AND CASTING SHOP SHOULD MAKE ALLOWANCES ACCORDINGLY.
2. ALL DIMENSIONS ARE IN MILLIMETRES UNLESS SHOWN OTHERWISE.

REGION OF WATERLOO AND AREA MUNICIPALITIES STANDARD DRAWINGS

REVISION DATE: FEB. 2008

SIDE INLET CATCHBASIN COVER

SSMS

E4 - 042

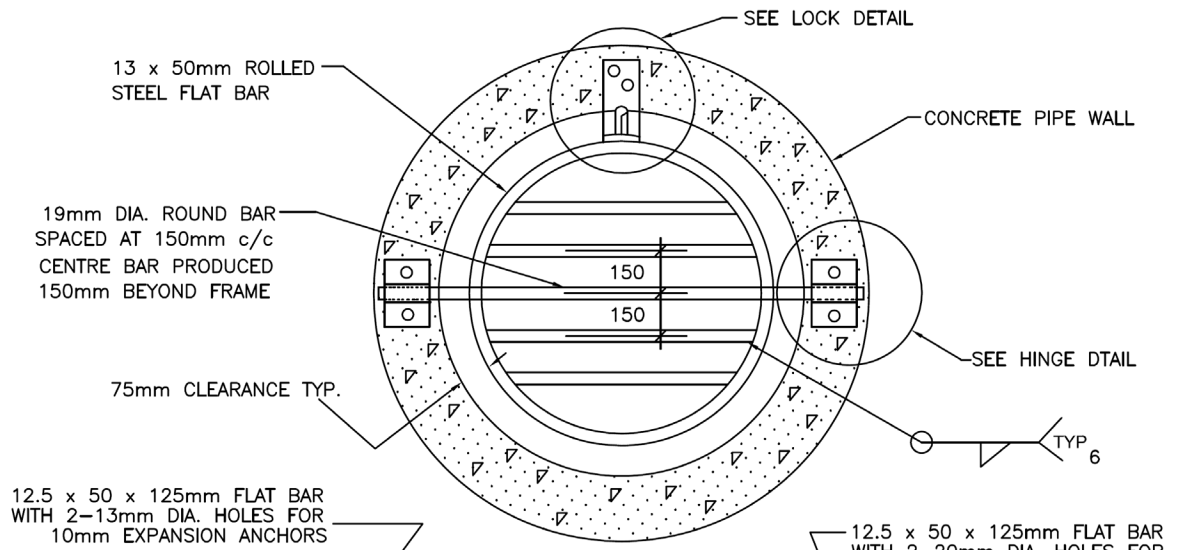

ELEVATION

12.5 x 50 x 125mm FLAT BAR WITH 2-13mm DIA. HOLES FOR 10mm EXPANSION ANCHORS

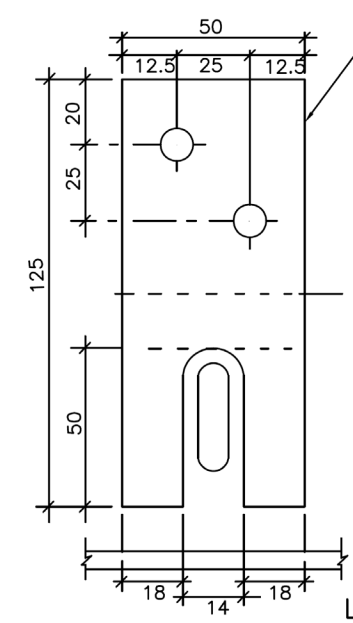

LOCK DETAIL

12.5 x 50 x 125mm FLAT BAR WITH 2-20mm DIA. HOLES FOR 16mm DIA. EXPANSION ANCHORS

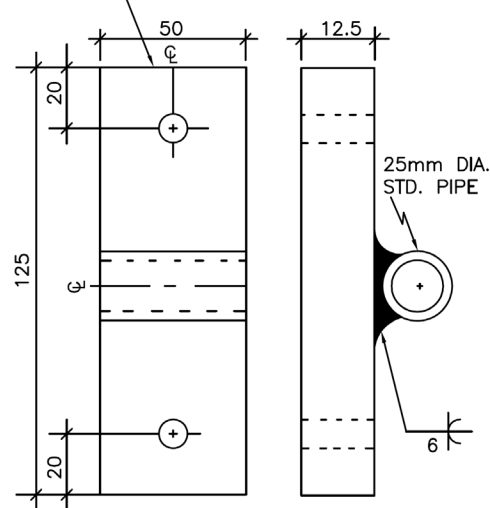

HINGE DETAIL

NOTES

1. WHEN ORDERING SPECIFY INSIDE DIA. OF PIPE.
2. STEEL TO : CSA CAN 3 G40.21 - M81 GRADE 300W.
3. WELDING TO : CSA W59.
4. DOUBLE HOT DIPPED GALVANIZE TO : CSA G164 - M.
5. ALL DIMENSIONS ARE IN MILLIMETRES UNLESS OTHERWISE SPECIFIED.
6. APPLIES TO PIPES 400 TO 1200mm DIA. FOR LARGER PIPES, BARS SHALL BE 25mm DIA. WITH VERTICAL BARS SPANNING 3 CENTRE BARS.

REGION OF WATERLOO AND AREA MUNICIPALITIES STANDARD DRAWINGS

REVISION DATE: FEB. 2008

INTERNAL GRATE FOR CONCRETE PIPE

SSMS

E4 - 05

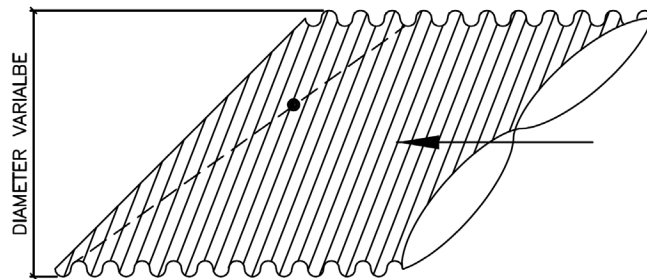
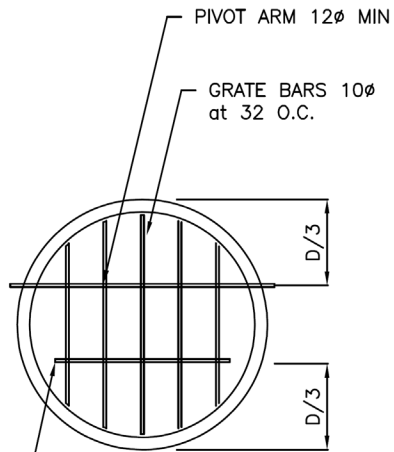

1. FOR 300mm ϕ PIPES AND OVER, ADDITIONAL 12mm ϕ HORIZONTAL GRATE BAR TO BE PLACED IN THIS LOCATION.
2. FOR PIPES LESS THAN 300mm ϕ , NO HORIZONTAL GRATE BARS REQUIRED.
3. ALL DIMENSIONS ARE IN MILLIMETRES UNLESS OTHERWISE STATED.
4. ALL MATERIALS TO BE DOUBLE HOT DIPPED GALVANIZED TO: CSA G164-M.

REGION OF WATERLOO AND AREA MUNICIPALITIES STANDARD DRAWINGS

REVISION DATE: FEB. 2008

**RODENT GRATE
FOR ATTACHMENT TO OUTLET**

SSMS

E4 - 06

ALTERNATE STANDARD HEIGHTS	
ALTERNATE	DIMENSION
A	1980
B	1830
C	1520
D	1380

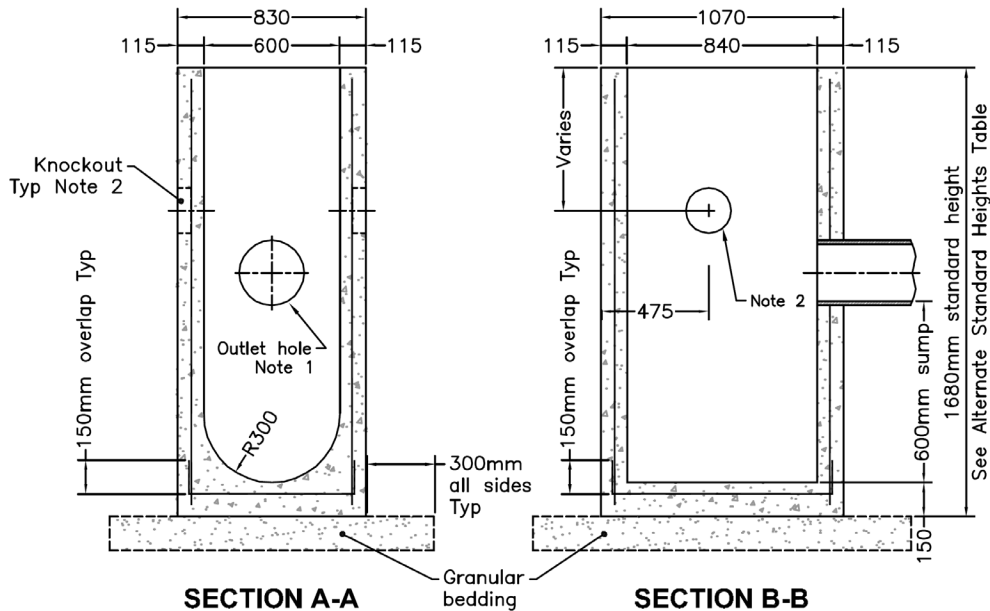
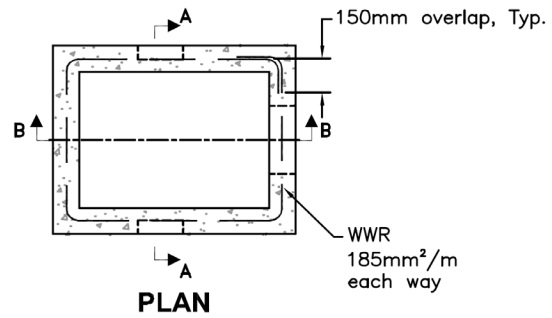

NOTES:

1. Outlet hole size 525mm diameter maximum, location as required.
2. 200mm diameter knockout to accommodate subdrain. Knockout shall be 60mm deep.
 - A. Centre reinforcing in base slab and walls ± 20 mm.
 - B. Granular backfill shall be placed to a minimum thickness of 300mm all around the catch basin.
 - C. Frame, grate, and adjustment units shall be installed according to OPSD 704.010 and 400.090.
 - D. Pipe support shall be according to OPSD 708.020
 - E. All dimensions are nominal.
 - F. All dimensions are in millimetres unless otherwise shown.

REGION OF WATERLOO AND AREA MUNICIPALITIES STANDARD DRAWINGS

DATE: JAN. 7, 2015

**PRECAST CONCRETE CATCH BASIN FOR
CURB INLET OVERFLOW 600x840mm**

SSMS

E4 - 07

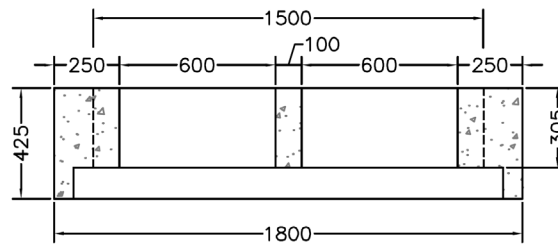
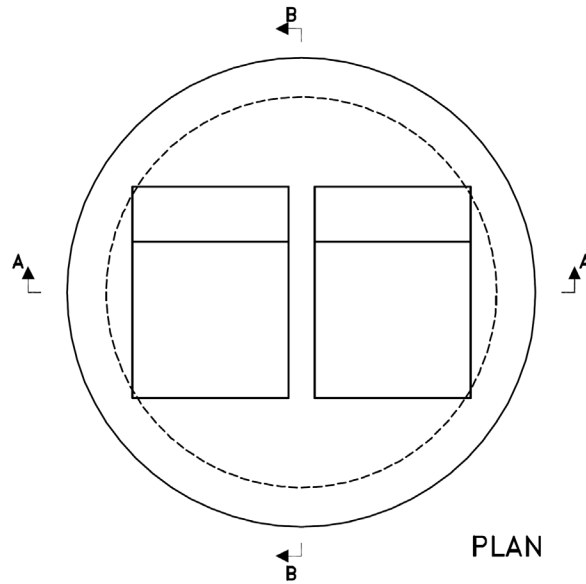

SECTION A-A

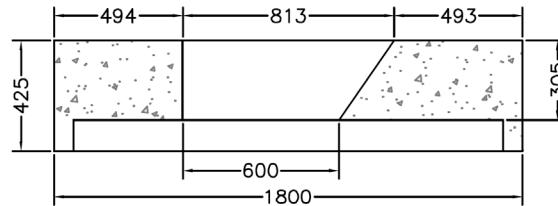

SECTION B-B

NOTES:

1. To be read in conjunction with OPSD 703.021 for reinforcement detail.
 - A. Frame, grate, and adjustment units shall be installed according to OPSD 704.010 and 400.090.
 - B. All dimensions are nominal
 - C. All dimensions are in millimetres unless otherwise shown.

REGION OF WATERLOO AND AREA MUNICIPALITIES STANDARD DRAWINGS

DATE: JAN. 7, 2015

PRECAST CONCRETE TWIN INLET FLAT CAP FOR CURB INLET OVERFLOW 1500mm DIAMETER

SSMS

E4 - 08

DESIGN SHEET E-DS1
Hydrostatic Pressure Test Template

Project Name: _____

Project Number: _____

Consultant: _____

Contractor: _____

Date: _____

Inspector: _____

Test Location: _____

Criteria: see OPSS **701**, building code or NFPA

Hydrant valves open: yes

Adjusted pressure due to elevation change: $p = [(1,000)(9.81)(\text{elevation change, wm high point} - \text{elevation at pump, in meters})] / (6,894.76 \text{ for psi})$

Pipe Class	Material	Diameter	Tested Length and description

Allowable Leakage Calculations:

Start Time of Test:	Start Pressure:
Finish Time of Test:	Finish Pressure:

Actual Period Main Under Test Pressure (Hrs)	
Allowable Volume Loss (L)	
Measured Volume Loss (L)	

Test Results: Satisfactory Unsatisfactory

Remarks:

Contractor: _____ Inspector: _____

DESIGN SHEET E-DS2
Tracer Wire Conductivity Test Template

Project Name: _____

Project Number: _____

Consultant: _____

Contractor: _____

Date: _____

Inspector: _____

Test Location:
 Street to Street
 Station to Station

Description to be
 provide on how tracer
 wire is connected to
 existing watermain

Gauge and type of
 equipment used by
 contractor:

Criteria: see DGSSMS D2.8.8

Parameter	Satisfactory	Unsatisfactory
Continuity Signal applied to tracer wire and the signal confirmed over the entire length of all tracer wire installed		
Tracing wire on services is connected to watermain tracer wire and wire is intact for the length of the service		
Tracing wire in chambers is detectable on the watermain outside of the chamber		

Test Results: Satisfactory Unsatisfactory

Remarks:

Contractor: _____ Inspector _____

PROJECT NAME
FROM – TO / DESCRIPTION
REGION / CITY / TOWNSHIP CONTRACT No. XXX

WATERMAIN COMMISSIONING PLAN

Note on use of this template:

This template attempts to provide a format and show example information needed for a wide range of watermain projects from a trunk main to a subdivision to a large water service. The user should edit, add or delete information and/or sections as may suit the particular application while still providing an adequate description of the work to be undertaken so that a timely review may be completed by the Contract Administrator and Operating Authority Representative. In Stage 1, the DGSSMS criteria are included for each section ahead of the project calculations as a reminder of the requirements to be met. The Commissioning Plan should be submitted at least 2 weeks prior to watermain installation so that source requirements and sampling points are known which may avoid the need to change construction plans or re-excavate a main to install an intermediate sampling point.

The following plan for temporary connection, swabbing, disinfection and testing of the watermain meets the requirements of the Region of Waterloo and Area Municipal Design Guidelines and Supplemental Specifications for Municipal Services (DGSSMS) **latest edition**. A sketch of the site is attached showing the system layout with source and sampling locations identified.

STAGING

In general, the new water system will be pressure and leakage tested in xx stage(s) comprised of the following areas:

Stage	Street	From	To
1	Street A	Exist St	Street B
	Street B	Street A	Street C
2	Street C	Street B	Street D
	Street D	Street C	Sta. x+xxx

STAGE 1

1 A. SAMPLE LOCATIONS

Samples will be taken from existing system facilities such as service laterals and air relief valve fittings, or temporary service laterals where necessary on long runs. When plugging temporary laterals, the main stop will be removed and replaced with a stainless steel plug in the stainless steel saddle.

Sample Point Number	Street	Station	Max. Distance from Source or Previous Sample Location (m)	Type of Sample Port
1-01	Street A	0+000	Source	Downstream of temporary connection
1-02		0+140	140	Temp copper off main stop for air relief valve
1-03		0+490	350	25 mm Service
1-04	Street B	2+168	180	Temp 19 mm service (to be plugged after testing)
1-05		2+480	312	Temp copper off main stop in valve chamber

1 B. TEMPORARY CONNECTION / WATER SOURCE

The watermain stage under test will be connected to the source as detailed below. A field-tested and CSA certified reduced pressure principle backflow preventer will be located in each filler line to prevent a possible reverse flow and contamination of the in-service source main. Any samples taken at the source end of the new main will come from the downstream side (new main side) of the backflow preventer.

Source and Filling

Street:	Name
Location (Station/intersection):	0+000
Source main size:	300 mm
No. of fill lines:	2
Fill line size:	50 mm
Flow rate per line:	3.5 litres/sec
Total flow rate of feed:	7.0 litres/sec

1 C. SWABBING

Swabbing will be done wet and 4 swabs will pass through all new mains. Water will be added to the pipelines ahead of the swabs by filling at xxxx (e.g. first filling from the source connection prior to launching the swabs, or adding water via the sample line at Sta. xxx, etc.). Swabs will be launched, travel at adequate cleaning speeds, and be retrieved as follows:

Street	Launch Station	Location Type	Pipe Size (mm)	Size (mm)	Swab Velocity (m/s)	Street	Retrieval Station	Location Type
Street A	0+000	Swab port	450	500	0.60	Street A	0+490	Open pipe
Street B	2+000	Insert in new pipe	150	200	0.85	Street B	2+480	Hydrant

1 D. HYDROSTATIC TESTING

As a minimum, the hydrostatic test pressure of 1035 kPa (150 psi) will be applied to all points of the watermain within the test section, including high points.

	Street	Station	Elevation (m)	Pressure kPa (psi)
Test pressure application point:	Street A	0+000	310.2	1132 (164)
High point	Street B	2+100	319.5	1035 (150)
Low point	Street B	2+420	308.0	1153 (167)

1 E. DISINFECTION and TESTING

Disinfection will be carried out in accordance with the MECP's 2020 Watermain Disinfection Procedure and AWWA Standard C651. Chemicals used for disinfection shall meet the requirements of NSF/ANSI/CAN 60. Chlorine will be injected into the new main at the source end at a rate that will result in a free chlorine residual of between 50 and 100 mg/l (ppm) throughout the new watermain. For tablet and continuous feed methods, the initial chlorine concentration shall be ≥ 25 mg/L. After 24 hours, the maximum allowable decrease in concentration is 40% of the initial concentration, to a maximum of 50 mg/L. While chlorinating, residuals will be checked at intermediate sampling locations. Less than 25 mg/L will require re-chlorination of the watermain. If acceptable readings are found, then flushing (de-chlorination) will commence. All chlorinated water will be neutralized to less than 0.2 mg/L total chlorine for discharge to a storm sewer or less than 0.002 mg/L total chlorine when there may be detrimental effects to the natural environment. After flushing, chlorine residuals will again be checked to ensure a free residual of at least 0.05 mg/L or a combined residual of at least 0.25 mg/L, and a total chlorine residual within 0.2 mg/L of the source water residual. Acceptable results will allow the first round of bacteriological samples to be taken. All testing and sampling will be performed in the presence of the Contract Administrator and all testing will be performed by properly certified personnel.

Type of chlorine:	xx% sodium hypochlorite / calcium hypochlorite / (name other)
Rate of water flow:	x.x l/sec
Rate of chlorine injection:	x.x l/sec
Time to chlorinate test section:	xx minutes
Neutralizing agent:	peroxide / sodium thiosulphate / (name other)

After the first round of bacteriological samples have been taken, the test section will be shut down (ie. no flow of water). Acceptable chlorine residual results will initiate the second round of bacteriological samples to be taken after a minimum of 24 hours after the first round. The chlorine at each sampling point will again be tested to ensure that the total remains no more than 50% less than the first round. Passed results shall have free residual of at least 0.05 mg/l or a combined residual of at least 0.25 mg/l.

Results of bacteriological sample analysis will be reported to the Contract Administrator who will in turn notify the Contractor. Acceptable results (E. Coli = absent, Total Coliform = absent, Background Bacteria <100) will allow the Operating Authority (or designate) to approve the final connection of the main to the existing system.

1 F. FINAL CONNECTIONS - <=/ ONE PIPE LENGTH

Final connections will be made in dry conditions in the presence of a Certified Operator representing the Operating Authority who will witness the installation and disinfection of the connection. The Contractor is required to submit a completed New Watermain Connection Checklist (where applicable), and all attachments including, but not limited to, the backflow prevention certification report and pre-post chlorination report, to the Operating Authority in order to obtain approval for final connection.

All required pipe and fittings will be sprayed or swabbed with a minimum 1% to maximum 5% sodium hypochlorite solution immediately prior to installation.

Type of Connection: remove cap/cut-in tee and sleeve/tapping sleeve and valve/other
 Gap to connect: 3.5 m
 Connection details: remove exist cap, install 450 pipe and solid sleeve

Subsequent to acceptable bacteriological testing and final connection, the municipality will be called to open the new main to regular service. Upon completion of the connection, the main will be flushed from the hydrant / service at Sta.x+xxx. Flushing through the connection shall be performed until a certified operator or Water Quality Analyst verifies that an Acceptable Disinfectant Concentration is present in the new watermain. If some occurrence during final connection indicates that the main may have been contaminated, a third round bacteriological sample will be taken.

STAGE 2

2 A. SAMPLE LOCATIONS

Samples should be collected at intervals of not more than every 350m, with at least one sample from the end of the watermain and from each branch greater than one pipe length (from AWWA 651).

Sample Point Number	Street	Station	Max distance from source or previous location	Type of sample port
2-01	Street C	3+000	Source	Temp copper off main stop
2-02		3+120	120	25 mm Service
2-03	Street D	3+410	290	Temp 19 mm service (to be plugged after testing)
2-04		4+075	140	25 mm Service
2-05		4+425	325	Temporary copper off main stop in valve chamber

2 B. TEMPORARY CONNECTION / WATER SOURCE

Source and Filling

Street: Jones St.
 Location (Station. /intersection) 3+000
 Source main size: 150 mm
 No. of fill lines: 1
 Fill line size: 50 mm
 Flow rate per line: 1.8 litres/sec
 Total flow rate of feed: 1.8 litres/sec

2 C. SWABBING

Water will be added to the pipelines ahead of the swabs by filling at xxxx. Swabs will be retrieved as follows:

Street	Launch station	Location type	Pipe size (mm)	Swab size (mm)	Swab Velocity (m/s)	Street	Retrieval Station	Location type
Street C	3+000	Swab port	200	250	0.70	Street C	0+490	Open pipe
Street D	Street C		150	200	0.85	Street D	4+480	Hydrant

2 D. HYDROSTATIC TESTING

	Street	Station	Elevation- m	Pressure- kPa
(psi)				
Test pressure application point:	Street C	3+000	310.2	1132 (164)
High point	Street C	3+200	319.5	1035 (150)
Low point	Street D	4+130	308.0	1153 (167)

2 E. DISINFECTION and TESTING

Type of chlorine: xx% sodium hypochlorite/calcium hypochlorite/(name other)
 Rate of water flow: x.x l/sec
 Rate of chlorine injection: x.x l/sec
 Time to chlorinate test section: xx minutes
 Neutralizing agent: peroxide / sodium thiosulphate / (name other)

2 F. FINAL CONNECTION

Type of Connection: remove cap/cut-in tee and sleeve/tapping sleeve and valve/other
 Gap to connect: 4.2 m
 Connection details: hot tap with 200x200 tapping sleeve and valve

Upon completion of the connection, the main will be flushed from the hydrant / service at Sta.x+xxx to rid the main of high chlorine. Flushing through the connection shall be performed until a certified operator or Water Quality Analyst verifies that an Acceptable Disinfectant Concentration is present in the new watermain.

----- *Copy and re-number Stage 2 format for each additional section of watermain being commissioned* -----

A.5 SAMPLE LOCATION LAYOUT

Attached is a plan(s) / sketch(es) showing the project's sample point numbers and their locations. Samples should be collected at a maximum of 150m from the source, at intervals of not more than every 350m, at the end of the watermain, from each branch greater than one pipe length, and at the end of services 100mm or larger.

This Commissioning Plan provided:

Date: _____ Date

Contractor: _____ Name of company

Commissioning Subcontractor (if applicable): _____ Name of company

Name of licensed testing technician (if known): Name

CHLORINE RESIDUAL MAINTENANCE PLAN

Last Update: June 2013

For development that is approved under a Subdivision Agreement, the Developer shall provide a Chlorine Residual Maintenance Plan. As a minimum, this Plan shall:

- Be completed and signed by the Developer's Design Engineer
- State the location of all permanent dead-end watermains as well as any temporary dead-end watermains that are created through phasing
- State locations where these dead-ends can be effectively flushed
- State the volume of water and frequency of flushing that each dead-end watermain is to receive to ensure that minimum chlorine residuals are maintained as stated in B 2.6.1. of the DGSSMS

This Plan shall be submitted to the Municipality for their review and approval no later than the Initial Acceptance of Underground, forming part of the Maintenance Package for Initial Acceptance. Each Municipality reserves the right to request this Plan during any of the earlier stages should they deem it necessary and will make the Developer aware of this requirement.

The form of flushing shall be determined by each Municipality (i.e. autoflusher, bleeds, manual flushing) and shall be given upon request by the Developer. Regardless of the method chosen, manual flushing and residual confirmation shall only be performed by Municipal licensed operators. All water used for flushing shall be recorded by the Municipality and charged to the Developer at the Municipality's current water usage rate. All labour, materials, and equipment associated with flushing and confirmation of residuals shall also be charged to the Developer.

The locations and frequency of flushing and associated costs charged to the Developer shall continue until such time of Final Acceptance of Stage Undergrounds. Prior to Final Acceptance, a location may be removed from regular flushing if a change has occurred in the water distribution system (i.e. build-out/occupation consumption, removal of temporary dead-end) that now allows residuals to stay above those stated in B 2.6.1. Formal request for removal is to be made to the Municipality with supporting documentation from the Developer's Design Engineer. Confirmation of this shall be verified by the Municipality prior to removal from the Chlorine Residual Maintenance Plan.

Upon final acceptance of the subdivisions water infrastructure, all responsibility for determining and maintaining flushing requirements and associated costs shall be that of the Municipality.



Region of Waterloo

FOR MUNICIPAL PROJECT MANAGERS: GROUNDWATER PROTECTION FOR CONSTRUCTION PROJECTS WITHIN 200 M OF A MUNICIPAL SUPPLY WELL

WATER SERVICES REQUIREMENTS

Last Updated: December 2017

1.0 INTRODUCTION

PURPOSE

The purpose of this document is to ensure that enhanced spill contingency plans and enhanced groundwater protection practices are in place during any construction work carried out close to (within 200 m) of Region of Waterloo municipal supply wells. Construction work includes utilization of heavy equipment, paving, dewatering, pile-driving, borehole drilling, stockpiling of construction-related supplies, subsurface excavation, and related activities.

This document is intended for design or construction Project Managers working at the Region of Waterloo or the cities and townships in the Region of Waterloo. These requirements should also be provided to Engineering Consultants working on applicable municipal projects.

BACKGROUND

The Region of Waterloo operates approximately 120 municipal supply wells, which provide about 80% of the Region's municipal drinking water. Enhanced spill/leak prevention measures are required close to municipal supply wells in order to protect the quality of the drinking water sources. Measures to avoid disturbing the filtration capacity of the ground near supply wells are also required.

In certain circumstances, for extra protection Water Services will modify the operation of production wells when there is nearby construction. This requires communication protocols between Water Services and the construction Project Managers.

The requirements of this document are in addition to regulatory requirements, including those dictated by the Ontario Environmental Protection Act, the Ontario Water Resources Act, the Region of Waterloo Source Protection Plan, The Regional Official Plan (Section 8), and municipal By-Laws.

This document outlines measures that would normally be imposed on construction projects within 200 m of a production well. However, recognizing the unique factors of each project and site, the construction Project Manager may negotiate a modified program with Water Services staff, if required. The Manager, Hydrogeology & Source Water (HSW) section of Water Services is the primary contact regarding this guideline.

RESPONSIBILITIES

POSITION	RESPONSIBILITY
Design or Construction Project Manager (municipal staff)	<ul style="list-style-type: none"> • Communicate overall work plan to HSW Manager at the earliest stage possible • Include requirements to prepare project-specific groundwater protection and spill mitigation plans in the consultant scope • Provide plans to HSW hydrogeologist for review and discussion • Ensure tenders include the applicable provisions from the groundwater protection and spill mitigation plans • Notify HSW Manager regarding the start date and end date of construction • Ensure groundwater protection and spill mitigation plans are carried out throughout the project
HSW Manager	<ul style="list-style-type: none"> • Assign HSW hydrogeologist to project, as needed • Communicate notifications to Water Services Operations staff as required for modified supply well operations and monitoring
HSW Hydrogeologist	<ul style="list-style-type: none"> • Review construction work scope and groundwater protection/spill mitigation plans and advise on BMPs • Recommend (if applicable) modified operations and/or monitoring that should be carried out by Operations and HSW staff • Site visits and project documentation as per Water Services procedures (due diligence)

2.0 REQUIRED ACTIONS

THE DESIGN/CONSTRUCTION PROJECT MANAGER SHALL:

- Be aware of the requirements of this document, and of Section 8 of the Regional Official Plan, and the Regional Source Protection Plan, and of the Regional Sewer Use By-Law.
- As early as possible, notify the HSW manager of planned construction work within 200 m of a Region supply well. Supply well locations are given in the Regional Official Plan and the Region's GIS system. The notification should include a summary of the work and expected timeline.
- Prior to issuing requests for consulting assignments and tenders, review the requirements of this document, and work with the assigned HSW Hydrogeologist to customize requirements for the RFP and/or bid documents.
- Ensure the contract includes details and provisions to carry out the groundwater protection and spill mitigation plans. This includes adding appropriate provisions to the consulting contract and contractor tenders, etc.

- During the construction work, ensure the groundwater protection and spill mitigation plans are carried out and keep the HSW Hydrogeologist informed of key events.

HSW HYDROGEOLOGIST SHALL:

- Review the groundwater protection and spill mitigation plans and ensure appropriate protocols are in place for the duration of the project, considering the site-specific well details and balancing the needs of the construction project.
- Recommend (to the Managers HSW and Operations) the applicable Water Services Protocol and/or SOP, to be implemented for the nearby well, including protocols for enhanced water monitoring, well shutdown, etc.
- Conduct as needed site visits (in coordination with the construction project manager), according to HSW SOPs and Protocols.
- Throughout the project the Hydrogeologist will inform the construction Project Manager and/or Water Operations staff if additional steps are needed to ensure security of the well and water supply.

3.0 RELATED DOCUMENTS AND CONTACT LIST

RELATED DOCUMENT	DOCUMENT LOCATION, SOURCE OR URL
Standard Practices For Construction Work Within 200 m Of A Municipal Supply Well	DOCS 2071070
Region of Waterloo Source Protection Plan	https://www.sourcewater.ca/en/source-protection-areas/resources/Documents/Grand/Grand_Plan_Vol_2_Ch10.pdf
Region of Waterloo Regional Official Plan (Chapter 8)	https://www.regionofwaterloo.ca/en/resources/Regional-Official-Plan/Chapter_8_Consolidated_New_ROP_2015-access.pdf

NAME/TITLE	PHONE NUMBER
Eric Hodgins/ Manager HSW	519-575-4434



Region of Waterloo

FOR CONSULTANTS & CONTRACTORS:

**STANDARD PRACTICES FOR CONSTRUCTION WORK WITHIN
200m OF A MUNICIPAL SUPPLY WELL
WATER SERVICES REQUIREMENTS**

Last Updated: January 2018

A.6 Purpose and Background

This document outlines enhanced contamination prevention measures for construction projects located within 200 m of a Region of Waterloo supply well. This document also helps to define environmental protection requirements in contract documents.

Construction work includes: utilization of heavy equipment, paving, dewatering, pile-driving, borehole drilling, stockpiling of construction-related supplies, subsurface excavation, and related activities.

The Region of Waterloo operates approximately 120 municipal supply wells that are the source of about 80% of the Region's municipal drinking water. Enhanced contamination prevention measures are required close to municipal supply wells in order to protect drinking water sources.

A.7 Standard Prohibitions

The following construction-related activities are prohibited **within 100 m** of a supply well:

1. Storage of chemical, materials, or waste (any amount)
2. Fuel storage or generators
3. Refueling of vehicles or equipment
4. Maintenance of vehicles or equipment
5. Placement of excess soil stockpiles
6. Placement of portable toilets

A.8 Standard Practices

The practices listed below are required for construction work within 200 m of municipal supply wells. These practices are also recommended for all other areas within the Region of Waterloo.

It is important to note that no work shall commence until all required plans are approved by the Hydrogeology and Source Water (HSW) Manager (or Designate).

- A.** A site-specific spill mitigation/ action plan, prepared in advance of construction by the Contractor and reviewed by the Consultant, must include suitable monitoring of the plan by both the Contractor and the Consultant. The plan must be submitted to the HSW Manager (or Designate) for approval prior to the start of work.
- B.** Secondary containment structures (e.g., spill pad, equipment “diaper”, etc.) for fuel, generators, and equipment/vehicles that contain fuel or chemicals.
 - These structures must have the capacity to both hold/contain any spills and allow for spill recovery/collection. An impermeable surface, such as a road, does not provide sufficient spill protection.
 - These structures can be inexpensive to build (by the Contractor) with readily available materials and fully customizable to meet the needs/requirements of each project.
 - Regular maintenance (by the Contractor) and inspection (by the Contractor and Consultant) of secondary containment equipment throughout the construction work is required, as well.
- C.** A storm water/excess water management plan, prepared in advance of construction by the Contractor and reviewed by the Consultant, must include suitable monitoring of the plan by the Contractor and the Consultant. The plan must be submitted to the HSW Manager (or Designate) for approval prior to the start of work.
- D.** In addition to spill reporting provisions as required by the Environmental Protection Act, any signs of contaminated soil or water encountered must be reported forthwith to the Water Services Contact Person(s) specified in the spill mitigation plan.
- E.** The Consultant (or Designate) must notify the designated Region of Waterloo Water Services Contact Person(s), 24 hours in advance of the start and end of any subsurface excavation, drilling, dewatering, or subsurface activities in the 100 m zone (100 m of an operating Regional production well).
- F.** A trained Hydrogeological Technician or Hydrogeologist must be onsite during subsurface work within 100 m of a production well, if the well is operating during the subsurface work; or the work occurs in the area of suspected subsurface contamination.

A.9 Requirements for Infrastructure

The following practices are required **within 100 m** of a Regional water supply well, and are recommended for areas **within 200 m** of a Regional water supply well.

1. New individual wastewater treatment systems, private supply wells, pipelines, sewers, stormwater management ponds (or other ponds) and the direct infiltration of water or storm water are not permitted.
2. New impermeable surfaces of any kind are restricted or minimized to the greatest extent feasible.
3. Replacement of storm or sanitary sewers must use enhanced construction techniques to achieve near-zero exfiltration leakage criteria.

A.10 Contacts

Eric Hodgins , Manager of Hydrogeology and Source Water, Region of Waterloo	(519) 575-4434
Water Services SCADA Desk (24 hours), Leave a message for Supervisor on call	(519) 571-6208

Region of Waterloo and Area Municipalities
Design guidelines and Supplemental Specifications
For Municipal Services
Part F
Product Approval Application Forms
Special Product Approval with Conditions



PRODUCT APPROVAL APPLICATION FORM

Watermains, Sewers and Roads

General Information and Instructions

General:

1. Information submitted on this form will enable Region of Waterloo Best Management Practice Technical Sub-Committee (BMP) to assess the Product identified.
2. In order for any Product to be accepted for use in the Region of Waterloo, the MANUFACTURER must be certified to the applicable product standard as outlined in the DGSSMS.

Instructions:

1. This form must be completed with respect to all the requirements in order for it to be considered as an application for approval. A complete application shall consists of the following:
 - i) a completed application form (ONE FORM PER PRODUCT);
 - ii) ALL required supporting information identified in this form;
 - iii) Certification from an Independent Certified Laboratory/Agency to show compliance with ALL current industry standards.

INCOMPLETE APPLICATION WILL BE RETURNED TO THE APPLICANT. The Region may require additional information during the technical review of any application accepted as complete.

2. The original application, along with the supporting information, must be sent to:

Mr. Jerry Borovicka Project Manager
The Regional Municipality of Waterloo, 150 Frederick Street, 6th Floor, Kitchener, Ontario, N2G-4J3

3. Questions regarding completion and submission of the application should be directed to the Region of Waterloo at (519) 575-4092

1. Company Profile			
Name			Type of Business
Address	City/Town	<input type="checkbox"/> Manufacturer	
Province/State	Postal/Zip Code	Country	<input type="checkbox"/> Supplier/Distributor
Contact Person	Telephone Number		<input type="checkbox"/> Contractor
Title	Fax Number		<input type="checkbox"/> Other (Specify)
E-mail Address	Company Web Site		
2. Product Description (Include product literature, detailed specifications and technical information)			
Product Name	Model/Code No.		Product Category
Manufacturer Name	Location of Manufacturing Plant/Foundry		<input type="checkbox"/> Water Systems
Year	Number of Years	<input type="checkbox"/> Wastewater Systems	
		<input type="checkbox"/> Storm Systems	
Samples Available For (Check All Applicable)			

Viewing Demonstration Testing

Road Systems
 Traffic Control Systems
 Other

Other Comments

3. Product End Use/Function and Special Features

End Use Function	Special Features	Approximate Cost

4. Current Approvals

Municipality	Contact Person	Phone Number
1		
2		
3		

5. Certified With Current Industry Standards (Must specify all applicable sections and attach supporting documents)

Standard	Section No.	Standard	Section No.	Standard	Section No.
<input type="checkbox"/> AWWA		<input type="checkbox"/> ASTM		<input type="checkbox"/> AASHTO	
<input type="checkbox"/> OPSS		<input type="checkbox"/> ANSI		<input type="checkbox"/> CGSB	
<input type="checkbox"/> OPSD		<input type="checkbox"/> FM		<input type="checkbox"/> ECO LOGO	
<input type="checkbox"/> CAN/CSA		<input type="checkbox"/> UL		<input type="checkbox"/> ETV	
<input type="checkbox"/> NSF		<input type="checkbox"/> Other			

6. List Three (3) Major Product Suppliers and/or Distributors (If applicable)

Supplier/Distributor Name	Contact Person	Phone Number
1		
2		
3		

For Office Use Only

Does the product meet the Region's required standards? <input type="checkbox"/> Yes <input type="checkbox"/> No If yes, which Regional Standard(s)?	Two (2) Year Probationary Approval <input type="checkbox"/> Granted <input type="checkbox"/> Exempted <input type="checkbox"/> Denied	Date
	Full Approval <input type="checkbox"/> Granted <input type="checkbox"/> Denied	Date

Comments

Best Management Practices

Technical Committee
c/o Water Services,
Region of Waterloo
150 Frederick Street, 7th Floor
Kitchener, ON N2G 4J3

December 7, 2009

Advance Drainage Systems, Inc./Hancor of Canada Inc.
2555 Thomas Street, Unit 88,
Mississauga, ON
L5M 5P6

Attn: Alex Navarro, Regional Engineer

Dear: Mr. Navarro

RE: Product Approval Request

On behalf of the BMP Technical Committee, I thank you for your demonstration on the dual-wall high-density polyethylene 100mm to 750mm on May 12, 2009. Your product demonstration at the Kitchener Utilities building was well received by BMP members. The BMP Technical Committee has reviewed your product in significant detail at various meeting times. As a result of this discussion we would like to add CSA 182.8 Profile Polyethylene Storm Sewer and Drainage Pipe and Fittings (latest version) to our list of standards in the DGSSMS document.

At this time the committee has warranted a probationary five (5) year trial period for the ADS/Hancor storm pipe product, under the following conditions;

- sizes range as per Municipalities requirements
- minimum 320kPa pipe stiffness
- water tight gasket (type 1) 74kPa
- shall meet OPSS 1840 requirements (latest version) and accredited by the Standard Council of Canada.
- 320 kPa PVC fittings shall be used
- Guelph has **not** accepted this product

Due to this product being approved under a warranted 5 year probationary period as per the committee's procedure for review of new products or materials, additional requirements are necessary;

- Consultant and manufacturer shall submit complete design details for each project proposed
- Installations to be monitored by manufacturer representatives
- Each probationary period installation must be fully documented to the satisfaction of the Committee and host Municipality
- Cost associated with the probationary period shall be borne by the applicant. These include but are not limited to: cost to remove or expose the product (in some cases), laboratory testing, pipe video and deflection test, and any other costs that may be deemed necessary by the Committee, to fully monitor and evaluate the performance of the product. Each test requirement will be evaluated based upon its own unique requirement



Best Management Practices

Technical Committee
c/o Water Services,
Region of Waterloo
150 Frederick Street, 7th Floor
Kitchener, ON N2G 4J3

- The Committee may impose additional terms and conditions as deemed necessary to fully evaluate the product.

This probationary approval can be cancelled or extended at the sole discretion of the Committee and subject to the performance of the product and the level of support provided by the manufacturer and suppliers.

Final approval will be based upon the satisfactory in-field performance of the product, documentation of the design and installation practice and at the sole discretion of the Committee. If the product is not used within the Region of Waterloo owned infrastructure within the first two years, the probationary period may be extended for, or the product may be rejected. The Committee may, at its discretion, have the product independently evaluated to determine suitability for its intended purpose and conformance to applicable standards. The cost for this independent evaluation would be borne by the applicant.

If you have any question please don't hesitate to contact the undersigned. On behalf of the BMP Technical Committee, I thank you for your interest.

Sincerely,

Bryan Bishop C.E.T.
Chair, BMP Technical Committee
Product Review Committee

- cc.
- K. Mick
 - J. Borovicka
 - A. Mick
 - R. Miller
 - P. Antoniow
 - G. Charbonneau
 - W. McLaughlin
 - I. Umar
 - R. Ormson
 - J. Cyperling



Township of North Dumfries