

# *Speed Laser*®

## USER'S GUIDE

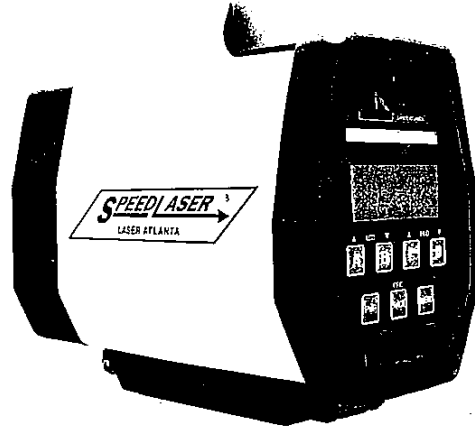

# **LASER ATLANTA**

 **davTECH**  
Analytical Services (Canada) Inc.



# ***S*PEED *L*ASER**

## **USER'S GUIDE**

---

**Laser Atlanta**  
2827 Peterson Place  
Norcross, GA 30071

Phone (770) 446-3866  
FAX (770) 840-0462

<http://www.laseratlanta.com>  
<mailto:sales@laseratlanta.com>

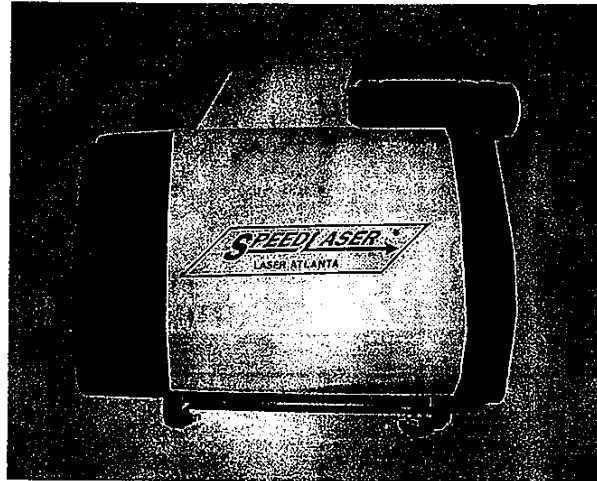

## TABLE OF CONTENTS

<b>1</b>	<b>INTRODUCTION .....</b>	<b>7</b>
	Cautions .....	8
	Capabilities .....	9
<b>2</b>	<b>GETTING STARTED .....</b>	<b>11</b>
	Packing List .....	11
	SpeedLaser Controls & Layout .....	12
	Battery Handle .....	14
	Connecting a Handle .....	14
	To Power ON .....	16
	To Power OFF .....	16
<b>3</b>	<b>SPEED MEASUREMENT .....</b>	<b>17</b>
	Measuring Speed .....	17
	Approaching and Receding Targets .....	18
	Manufacturer's Recommended Daily Test .....	19
	Range (Mapping) Measurement .....	23
<b>4</b>	<b>USER SETTINGS .....</b>	<b>24</b>
	Intensity and Contrast .....	24
	LCD Backlight .....	24
	LCD Contrast .....	24
	HUD Brightness .....	24
	The MENU System .....	25
	Test Mode .....	28
	Audio .....	29
	HUD Mode .....	30
	Obstructed .....	32
<b>5</b>	<b>APPENDICES .....</b>	<b>34</b>

## APPENDICES

A	Troubleshooting/Error Messages	32
B	Care and Maintenance	33
C	Technical Specifications	35
D	SpeedLaser and Accessory Diagrams	36
E	Measuring Surface Datum	37
F	Battery Handles Notes	38

Warranty

Rear Cover

## CHAPTER 1 Introduction

Thank you for purchasing the SpeedLaser from Laser Atlanta. This rugged laser speed gun integrates the latest in solid-state laser technologies to bring you hand-held, eye-safe laser speed and distance measurement.

The SpeedLaser is a Class 1 eye safe, multi-function device generally used to measure range and speed of targets up to 9,144 meters away.

The technology utilized by the SpeedLaser is called LIDAR: Light Detection And Ranging. Your SpeedLaser measures the time it takes a pulse of laser light to travel from the LIDAR to the target vehicle and back (pulsed time-of-flight). This round trip time is converted to a distance ( $d=ct/2$ ). The distance to the target vehicle is measured in this manner over two hundred times per second. Sophisticated computer algorithms combine these individual distance measurements to compute the extremely accurate speed measurements displayed.

To get the most from your new SpeedLaser, please take the time to read through this manual. For your convenience and ease of understanding, it has been divided into 4 sections:

Chapter 1	Introduction
Chapter 2	Getting Started
Chapter 3	Speed Measurement
Chapter 4	User Setting's
Appendices	Information on care, troubleshooting, and specifications

If you have questions or comments, please do not hesitate to contact Laser Atlanta via any of the following means:

voice: (770) 446-3866  
fax: (770) 840-0462

Email: [sales@laseratlanta.com](mailto:sales@laseratlanta.com)  
Web: <http://www.laseratlanta.com>

## Cautions

Every step has been taken to ensure your SpeedLaser is completely safe to use. However, certain common sense precautions should always be taken when using your SpeedLaser.

- Do not open the case under any circumstances.
- Do not point the SpeedLaser directly at the sun.
- Use only Laser Atlanta approved power sources.
- Do not leave SpeedLaser in areas of high humidity.
- Do not place SpeedLaser on unstable surfaces.
- Always transport the SpeedLaser in its carrying case.

Your SpeedLaser is a Class 1 Laser Product that complies with 21 CFR 1040.10 and 1040.11. Class 1 is the lowest classification of laser product with regards to risk in use. This class of laser cannot emit levels of optical radiation above the exposure limits for the eye, under any exposure conditions inherent to the laser product.

**Caution: The use of optical instruments with this product will increase eye hazard. Do not point this laser at anyone with optical viewing devices within 15 meters of the operator.**

Although optical viewing instruments may increase eye hazard, it is unlikely that actual damage can occur. Prescription eyeglasses, contact lenses, and sunglasses are not considered optical gain devices since they merely correct the focus of the human eye to normal.

Optical devices that provide magnification may increase the risk of eye-hazard. These include binoculars, telescopes and magnifying glasses.

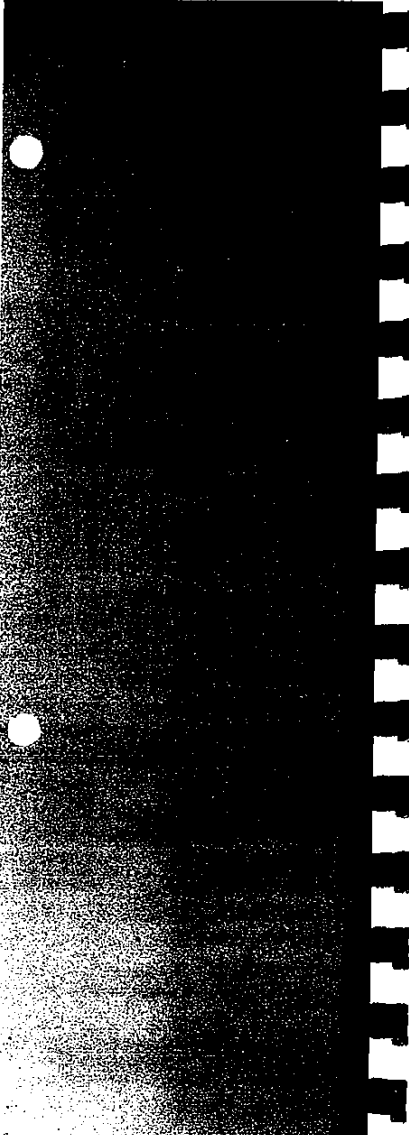

### Capabilities

### Performance

- Target Acquisition in 0.3 seconds
- Speed Accuracy of  $\pm 1$  km/h
- Range to 9144 meters

### Advanced Input-Output

- Remote Fire trigger switch
- Full Remote control via RS-232 port
- Data Collection via RS-232 port
- Data Collection via PCMCIA SRAM Cards

### Ease of Use

- Menu Driven
- Head Up Display (HUD) shows both target and speed/distance data through the same sighting mechanism
- Rechargeable NiMH Battery Handle
- 12 V Cigarette Adapter
- Optional 8X Monoscope for distant viewing
- Optional Shoulder Stock for steadying while hand-held
- Optional Monopole and Tripod for mounting
- Optional Mapping system upgrade

### Environmental Features

- Water Resistant
- Ruggedized Case
- Rechargeable NiMH Battery Handles

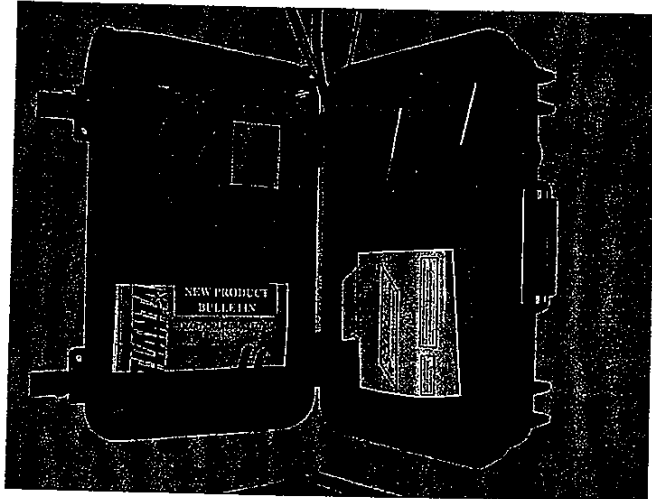

Chapter 2  
Getting Started

## PACKING LIST

---

Please check to make sure the following items were included in your shipment:

- SpeedLaser LIDAR Gun
- 2 Battery Handles
- Carrying Case
- 110 volt Battery Charger
- 12 volt Charging Cable
- 12 volt Vehicle Power Cable
- User's Guide
- Warranty Card

Additionally, you may have received the following optional parts:

- RS-232 Serial Data Cable
- 8X Monoscope Kit
- Shoulder Stock Kit

Please see Appendix D for diagrams of these items.

# SpeedLaser Controls & Layout

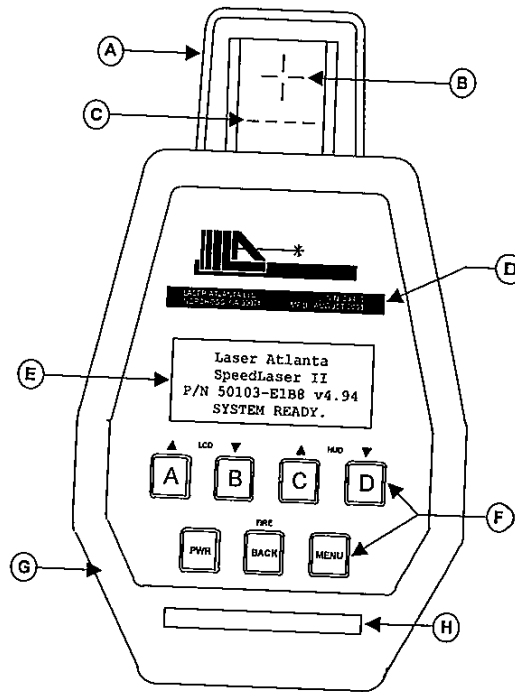

- A: Head Up Display (HUD)
- B: HUD Sighting Reticle
- C: HUD Character Display
- D: Serial Number
- E: Liquid Crystal Display (LCD)
- F: Keypad Keys
- G: Rear Bumper
- H: PCMCIA Card Slot

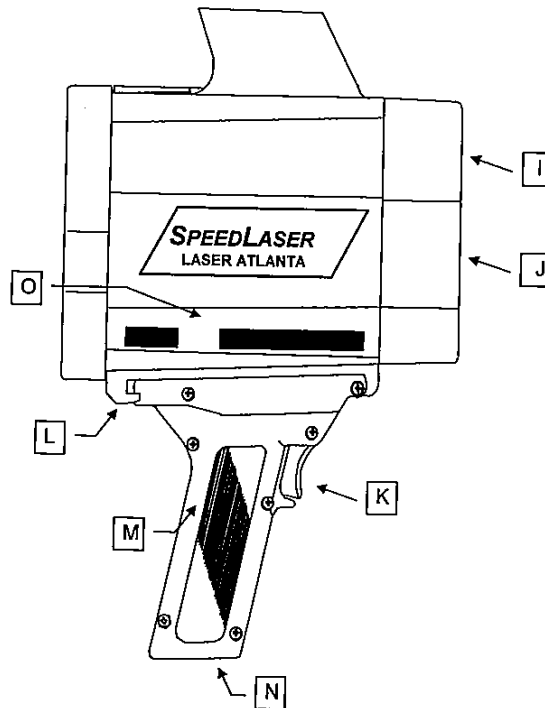

- |                    |   |
|--------------------|---|
| I: Transmit Optics | M: Battery Handle   |
| J: Receive Optics  | N: External Data Port<br>(Tripod mountable handle<br>has data port on the side) |
| K: Handle Trigger  | O: Laser Warnings   |
| L: Handle Latch    |   |

### Battery Handle Power

The SpeedLaser comes equipped with two (2) rechargeable battery handles. They have been shipped uncharged, so you will need to charge them (10 hours) with the wall charger or 12V cigarette cable completely before first use. Each handle will provide an average of five (5) hours of continuous use per charge.

These handles are also capable of powering the SpeedLaser from a 12V source such as an automotive cigarette power adapter using the cable provided. Plug the small circular connector onto the bottom of the handle and the cigarette adapter end into an automotive cigarette-power adapter. You can charge the handles in this manner as well as operate the unit.

#### To charge your battery handle:

1. Plug the circular connector into the side of the handle. Do not force the connector as it is keyed...slowly rotate the connector (holding the black rubber) and push gently until it clicks and locks into place.
2. Plug the charger into a standard 120 VAC power receptacle OR plug the cigarette adapter into a power source.
3. Charge the handle for ten to twelve hours.
4. To remove the connector, pull gently downward on the outside of the metal connector.
5. Unplug the charger from the wall. The handle is now charged.

#### CAUTION: DO NOT

- Charge handles with other chargers/power supplies
- Short circuit the battery pins
- Charge handle for over sixteen (16) hours continuously

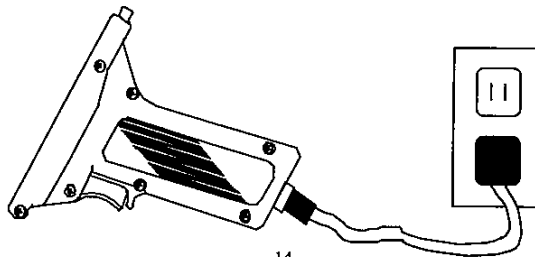

### Connecting a Handle

To install a handle onto the SpeedLaser:

1. Press the handle latch forward on the handle.
2. Push the front of the handle into the front handle catch on the bottom of the SpeedLaser.
3. Rotate the rear of the handle upward.
4. Release the handle latch.

NOTE: Make certain the handle latch slides into position and secures the handle to the SpeedLaser. If necessary, push the handle latch rearward to secure the handle to the SpeedLaser.

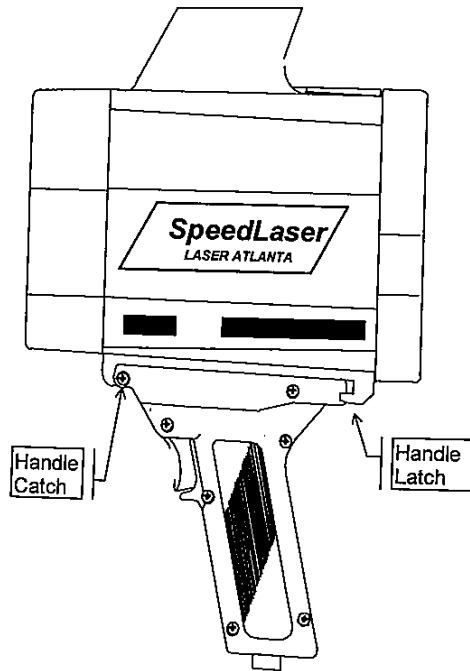

## Turning the SpeedLaser ON and OFF

### To POWER ON

- 1) Press the PWR key on the back of the SpeedLaser and hold for one second.

Note: The self-test (pg. 19) will automatically run when the unit is first powered ON. When the self test is completed successfully the LCD will display "SYSTEM READY"

### To POWER OFF

- 1) Press and HOLD the PWR key on the back of the SpeedLaser for three seconds.

Note: Keep the key pressed until no information is displayed on the LCD. If the button is not depressed for a long enough time, it toggles the LCD backlight ON and OFF.

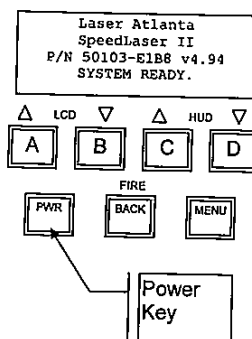

## Chapter 3 Speed Measurement

When the SpeedLaser is first turned ON, it automatically runs the self-test function. To capture a speed, simply follow the procedure below.

### MEASURING SPEED

**\*Always verify operational procedures for Alignment Check\***

1. Align the HUD Sighting Reticule (+ symbol in the HUD) on the target you wish to measure the speed of.
2. Squeeze and hold the Handle Trigger till the speed is displayed.
3. Release the Handle Trigger to stop measurement and lock information in the HUD and on the LCD.

The speed will be shown in three places...twice on the rear right of the LCD and also in the HUD (when selected) character display. Notice that two of the speed displays are truncated to the nearest kph.

The distance to the target will be shown on the left side of the LCD.

**NOTE:** Pressing the trigger will take you to the *Speed Display Page* regardless of any other mode the SpeedLaser may be in. (The exception is when in the TEST mode.)

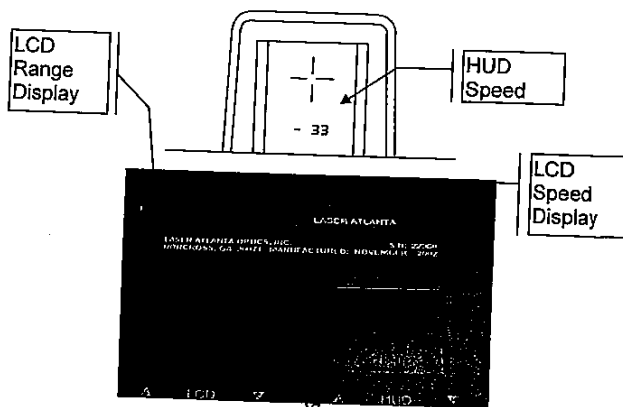

## APPROACHING AND RECEDING TARGETS

The SpeedLaser can measure the speeds of both approaching (oncoming) and receding targets.

The speed displayed in the HUD and on the LCD will be preceded by a '-' when the target is receding.

### Example of an Approaching target

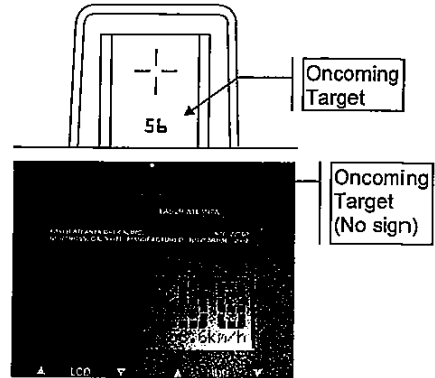

### Example of a Receding target

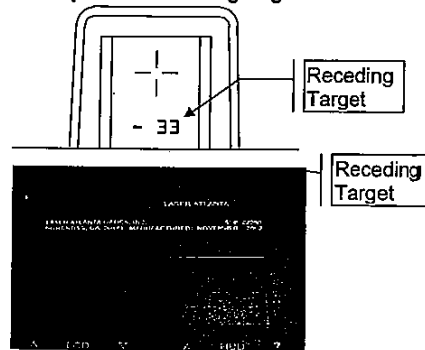

## **Manufacturer's Recommended Daily Test**

In keeping with NHTSA (National Highway Traffic Safety Administration) and IADLEST (The International Association of Directors of Law Enforcement Standards and Training) general operational considerations for LIDAR Speed Measurement devices the operator must perform the following accuracy checks prior to beginning enforcement operations:

- 1) Internal Circuit Check
- 2) Light Segment Test
- 3) Range (Chronometer) Accuracy Test
- 4) Horizontal Sight Alignment Test
- 5) Vertical Sight Alignment Test

## **WHAT THE DAILY TEST ACCOMPLISHES**

To ensure that the SpeedLaser is in good working order, the SpeedLaser should be tested using the Manufactures daily test described later in this chapter. This test restores the factory default settings, checks the LIDAR hardware, including the program and dynamic memories, tests the displays and timing circuits and then allows the operator to verify that the HUD aiming crosshairs are correctly aligned with the laser beam.

Note: The alignment crosshairs in the HUD are set at the factory and generally do not need realignment over the life of the SpeedLaser.

### **1) Internal Circuit Check**

When the operator presses Menu>Test (Menu>A) the SpeedLaser runs a BIT (Built-In-Test) program. The BIT program tests the hardware and verifies that the SpeedLaser firmware is loaded correctly. It then checks that the processor is executing the data gathering, storing (memory), sorting, filtering, conversion and linear regression algorithms correctly.

### **2) Light Segment Test**

Allows the operator to verify that the seven segment display used to show speed of the target vehicle is in good working order by displaying a simple known pattern. The operator can then confirm that each segment operates correctly.

### **3) Range (Chronometer) Accuracy Test**

The SpeedLaser hardware ONLY measures Time. Range and Speed are computed values derived from multiple time measurements by the firmware that was checked for proper operation during BIT. The design of the firmware was verified as part of the IACP certification process.

This test uses the SpeedLaser high speed chronometer (timer) to measure the time it takes a light pulse to travel a known distance (i.e.; from the SpeedLaser to a target at a known distance and back). Since the speed of light in air is known, the SpeedLaser can calculate the range that the light pulse traveled. The operator then compares the reported range to the known distance to the target. To verify that the timing hardware is working correctly the computed range must match the known distance to within one third (1/3) of a meter. At least two such comparisons using targets at least six (6) meters apart must be made.

In normal operation the SpeedLaser measures the time it takes for a light pulse to travel from the SpeedLaser to a moving vehicle and back. The SpeedLaser makes hundreds of such round trip time measurements each second, each time measurement is converted to a range and stored. When the SpeedLaser has sufficient stored ranges, it performs a linear regression calculation that yields the speed of the vehicle. Numerous firmware filters are used to confirm the computed speed before it is displayed.

### **4) Horizontal Sight Alignment Test**

This is a test to confirm that the sighting system and the invisible light pulse emitted by the SpeedLaser are aligned horizontally. The operator uses the sighting system to aim at an object and then confirms that the light pulses of the SpeedLaser are hitting that object by observing that the SpeedLaser is reporting the range to that object. The operator then moves the sighting system off of the object and observes that the reported range changes just as the sighting system is no longer on the object.

### **5) Vertical Sight Alignment Test**

Same as Horizontal alignment test but in the vertical axis

## Running the Manufacturer's Recommended Daily Tests

### 1) Internal Circuit Check

Press MENU > TEST (MENU A) The LIDAR will:

- a) Enter the TEST/RESET Mode
- b) **Restore factory default settings**
- c) Run the internal circuit check
- d) Run the program and dynamic memory test
- e) Runs an LED count test (1111, 2222, ..., 9999)
- f) Defaults the HUD display to 8888

Wait for then Confirm Memory-OK is displayed

### 2) Light Segment Test

Confirm the HUD is displaying the aiming + with the data 8888

### 3) Range (Chronometer) Accuracy Test

Confirm that the LIDAR can correctly compute two or more known ranges using any **one of the following methods:**

- a) Stand at one position, range to two targets at known distances.
- b) From two locations, range to one target with known distances.
- c) Range to a random target, back up a known 'delta' distance, confirm LIDAR computes a new range with the same delta distance, back up a second but different delta distance, confirm LIDAR computes a new range that matches the new delta range.
- d) Combine method a) with the horizontal and vertical alignment tests (4 and 5) below. This requires that the targets used for the Horizontal and Vertical alignment be at different known ranges.

**Using your preferred method from above**

- a) Stand at the selected position.
- b) Aim at selected target.
- c) Squeeze and hold trigger until tone sounds (range is computed).
- d) Confirm reported range is within  $\pm 1/3$  of a meter of expected.
- e) Repeat steps a) to d) using a known distance that is at least 6 meters different the first known distance.

**Continued on next page**

#### 4) Horizontal Sight Alignment Test

- a) Locate a tall, vertical object (such as a utility pole) with clear sky behind it (and preferably > 45 meters away.)
- b) Aim to the right of the object, and pull the trigger.
- c) While keeping the trigger pulled, slowly sweep the crosshair sight to the left. Press (D) Done when completed.
- d) The distance should be displayed in the HUD **only** when the target edge is in view of the crosshair.

#### 5) Vertical Sight Alignment Test

Turn the unit 90 degrees sideways. Repeat steps 4) a – d.  
Press MENU or DONE to exit Test Mode.

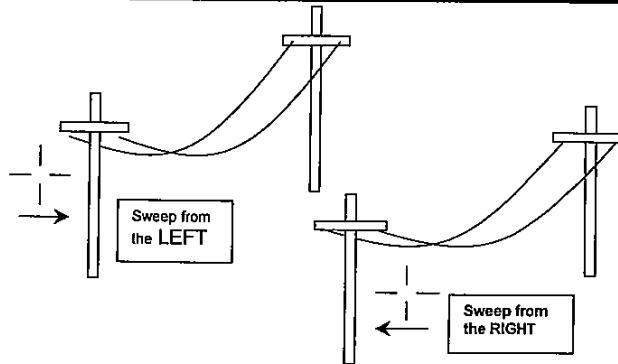

## RANGE (MAPPING) MEASUREMENT

To make a range measurement:

1. Press Power.
2. Press **MENU > HUD > Mapping > MENU**
3. Align the HUD Sighting Reticule on the target that you wish to measure the range to.
4. Squeeze and hold the Handle Trigger.
5. Release the Handle Trigger to stop measurement and lock the measurement data temporarily in the HUD and on the LCD.

Notice that the distance displayed in the HUD is always rounded to the nearest meter.

To return to Speed Measurement press:  
**MENU > HUD > Speed > MENU**

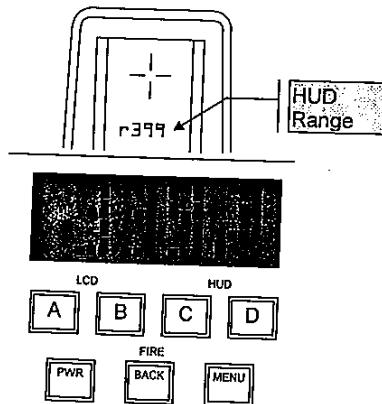

## Chapter 4

# User Settings

## INTENSITY AND CONTRAST

---

The contrast / intensity of the SpeedLaser are set outside of the Menu system. Above each letter is a symbol that shows what the key function is outside of the menu. Before entering the menu you can Activating the Backlight or set the LCD contrast or the HUD intensity

While factory reset (Menu > Test) will turn off the backlight, the LCD contrast and HUD intensity are only set by the user. This allows an appropriate intensity/contrast set to be established before running the daily test.

---

### LCD Backlight

Turning On the LCD Backlight

Briefly pressing the PWR button will toggle the backlight ON and OFF.

---

### LCD Contrast

Adjusting the LCD Contrast

- The A key adjusts the LCD Contrast HIGHER.
- The B key adjusts the LCD Contrast LOWER.

### HUD Brightness

Adjusting the LCD Contrast

- The C key adjusts the HUD intensity HIGHER.
- The D key adjusts the HUD intensity LOWER.

## THE MENU SYSTEM

The SpeedLaser provides a number of user settable features to help the user in making speed and distance measurements. These are accessible from the sub-menus. The menu system is reached by depressing the MENU key from the SPEED page.

- The top left of the LCD displays the Menu Name.
- The top right of the LCD displays the Menu Page. This reflects which keys have been pressed since the top menu page (Pg 0).
- Other lines list choices selectable by the A, B, C, and D keys.

The menu system is negotiated via the following keys:

A Select choice A  
B Select choice B  
C Select choice C  
D Select choice D

BACK Go back to the previous menu page  
MENU Exit the Menu and return to SPEED page

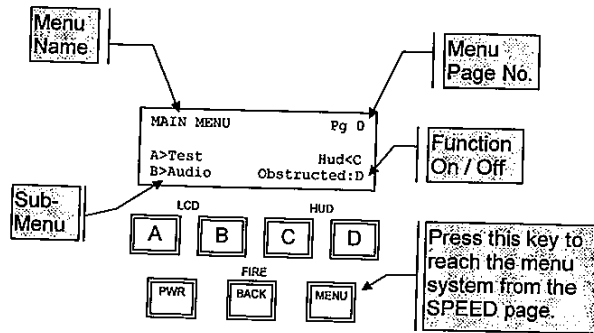

**> or <**

When the '>' symbol appears next to a letter key, pressing that letter key will select the named sub-menu.

:

When the ':' symbol appears next to a letter key, the named function is currently set to OFF. Pressing this letter key will turn ON the named function. If the function is of a "choose one" nature, then the related functions will automatically be turned OFF.

@

When the '@' symbol appears next to a letter key, the named function is currently set to ON. If the function is of an "on/off" type, then pressing this letter key will turn OFF the named function. If the function is of a "choose one" nature, then you must select one of the other functions to turn this function OFF.

---

Please note that the current settings are automatically saved, even when the power is turned off, and even if the battery handle is removed.

When the **Daily Test** is run, the SpeedLaser automatically reset all settings to their factory **default** values.

The remainder of this Chapter presents a diagram and description of each sub-menu.

To quickly access any desired menu, press the MENU key and then the sequence of letter shown at the top right of the display diagram on any page.

For example, to select the Audio Quality Chirp, you would press the following keys in sequence:

MENU | Audio | Quality Chirp or  
MENU | B | C

## Main Menu

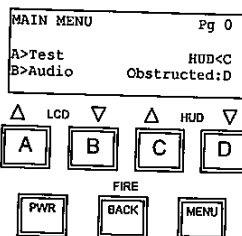

#	Action	Key
1	Turn On	PWR
2	Select MENU	MENU

The Main Menu is the starting menu page for all user configurable functions. These functions are divided into four groups:

- Test
- Audio
- HUD
- Obstructed

See the Menu Tree and the description pages that follow for instructions on using these settings.

**Reminder:** The user settings are remembered until the Test menu is run. The gun will revert to standard factory settings when the Test menu is selected.

**Note:** The self-test diagnostic functions are also performed automatically upon powering the gun on.

**Test Mode**  
**Performing the Self-Test**  
**MENU A**

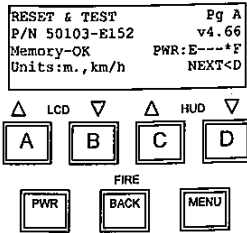

#	Action	Key
1	Turn On	PWR
2	Select MENU	MENU
3	Select TEST MODE	A

The self-test performs the following functions:

- The SpeedLaser setting are restored to their factory default values.
- The software Part Number and Version are displayed in the LCD.
- The program and storage memories are tested.
- The battery voltage is displayed on an Empty - - - - Full scale.
- The speed and distance units of measure are displayed on the LCD. (Note: These units are pre-configured at the factory and cannot be set by the end-user.)
- All LED segments in the HUD are cycled through the numerals 1 to 9 and then finally displayed as 8888.
- Range (distance measurement) mode is automatically turned on. This allows the operator to perform the range (chronometer) and alignment checks (see procedure starting on page 19.)

If any of the diagnostic functions fail, a failure warning will be displayed on both the LCD and in the HUD. A warning tone will sound and the SpeedLaser will prohibit firing of the laser. The operator should attempt to power the unit down and back on and run the self-test again.

Audio  
 Toggling the beeper tone ON and OFF  
 MENU DA

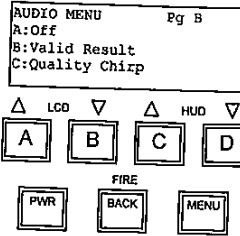

#	Action	Key
1	Turn On	PWR
2	Select MENU	MENU
3	Select AUDIO	A
4	Select preference Off   Valid   Quality	A   B   C

If selection A: Off is NOT selected, the unit will emit a short beep each time a menu key is pressed.

If selection B: *Valid Result* or C: *Quality Chirp* are selected, the audio beeper will sound for the following conditions:

**Valid Result** The beeper will emit a tone when a valid speed or distance measurement is made.

**Quality Chirp** When the SpeedLaser is making a speed or distance measurement (in Range Average or Real-time Range modes only), a tone representative of the quality of the received laser signal is sounded. When strong laser returns are acquired, the tone will be solid. Weaker returns will give a weaker, broken tone.

**Note:** The following conditions will signal an alarm regardless of the settings on this menu page.

**Voltage Low** A solid tone will sound when the voltage is low.  
**Fail** Any failure mode will sound a solid tone.

## HUD Mode

Setting what information is displayed on the HUD  
MENU C

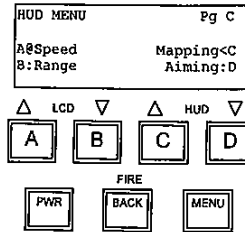

#	Action	Key
1	Turn On	PWR
2	Select MENU	MENU
3	Select HUD MENU	D
4	Select preference	A   B   C   D

This setting chooses what is displayed in the HUD; *Speed*, *Range*, *both Speed and Range*, or *Accident Mapping data* and selects the *Aiming Reticle Menu*

*Speed* Select A to exclusively display Speeds in the HUD.

*Range* Select B to exclusively display distances in the HUD.

### Both Speed and Range

Select both A and B to alternately display Speed and Distance in the HUD. The values will rotate between the current speed and the current range.

*Mapping* Select C to used the SpeedLaser with the optional mapping accessories to map an Accident Scene. This sets the SpeedLaser to measure ranges using the stationary range only algorithm found the Advantage Mapping/GIS product.

*Aiming* Pressing D selects the HUD Menu uses to control the appearance of the aiming reticle.

## AIMING MENU

Setting the appearance of the HUD aiming reticle  
MENU CD

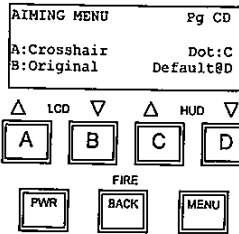

#	Action	Key
1	Turn On	PWR
2	Select MENU	MENU
3	Select HUD MENU	C
4	Select AIMING MENU	D
5	Select preference	A   B   C   D

This setting chooses the appearance of the HUD aiming reticle. The four choices are shown on the next page

**Crosshair** Select A to display a reticle with a gap aspect ratio similar to the end view of a vehicle. The width of the laser beam matches the width of the gap in the center of the reticle.

**Original** Select B to display a reticle with a square gap. The width of the laser beam matches the width of the gap in the center of the reticle.

**Dot** Select C to display a small dot in the center that will be located in the center of laser beam. The laser beam is larger than the dot.

**Default** Select D to display the small dot in the center that will be located in the center of laser beam and to display the original square gap reticle. The width of the laser beam matches the width of the gap in the center of the reticle.

AIMING MENU continued

Crosshair



Original



Dot



Default



**Obstructed**  
Turning the Obstructed mode On / Off  
MENU D

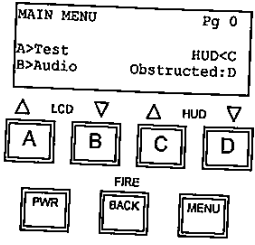

#	Action	Key
1	Turn On	PWR
2	Select MENU	MENU
3	Obstructed (Toggles On / Off)	C

Set to ON when firing the LIDAR through the patrol vehicle window, or when RAIN, SNOW, FOG or other OBSTRUCTS are present.

Normally LIDARs attempt to compute the speed of the first object that each laser pulse strikes. When standing in the open on a clear day this works well. But when a LIDAR is used from inside a vehicle on when the weather is bad or when objects like bushes and sign post partially block the view of the target vehicle, this approach does not work as well.

The SpeedLaser Obstructed On/Off setting is an advanced filtering mode that allows the SpeedLaser to process multiple ranges for each laser pulse. The LIDAR sees both the target vehicle and the obstructing object (rain, patrol vehicle window, snow, chain link fence, etc) and can filter out the random items like snow and the obstructing items like the window, allowing speed to be compute for the selected target vehicle.

This method does not require limiting the minimum range or having the operator set up some small target window. In fact Obstructed works from the standard minimum range of 2 meters out to over 900 meters.

## APPENDIX A TROUBLESHOOTING PROCEDURES

If you suspect your SpeedLaser is malfunctioning, please check the following items:

### Troubleshooting

Symptom	Possible Cause
SpeedLaser won't power on	Battery not charged sufficiently; 12 V adapter not plugged in
SpeedLaser won't range to extremely distant targets	Target not reflective enough, target too far away, Lens Blocked or fogged
Cannot see HUD displays	HUD Brightness set too low

### Error Messages

Error Message	Message Meaning	Operator Action
EEPROM Data Not Found	SpeedLaser setup defaults not located	Cycle Power
HELP	Voltage too low	Recharge the Battery Handle
Low Battery	Voltage too low	Recharge the Battery Handle

If you are unable to resolve the problem on your own, please contact Laser Atlanta Technical Support by any of the following methods:

voice: (770) 446-3866 fax: (770) 840-0462  
email: [techsupport@LaserAtlanta.com](mailto:techsupport@LaserAtlanta.com)  
<http://www.LaserAtlanta.com>

If you need to return your unit for service, please call first to receive a Return Materials Authorization (RMA) number.

## APPENDIX B

### CARE AND MAINTENANCE

#### General Care Considerations

##### DO

- Transport the SpeedLaser in its carrying case
- Occasionally clean the SpeedLaser Optics (see procedure below)

##### DO NOT

- Operate while the battery charges
- Point the SpeedLaser at the sun
- Place on unstable surfaces
- Open the SpeedLaser

#### CLEANING THE SPEEDLASER'S OPTICS

---

**WARNING!** The SpeedLasers optical surfaces are coated glass. Care must be taken when cleaning these surfaces. Scratching the lenses may lead to reduced performance.

##### Surfaces to Clean

The LASER TRANSMITTER OPTICS, RECEIVER OPTICS, HUD COMBINER GLASS, and HUD SEALING WINDOW may be cleaned as needed.

##### Materials

1. Lint-free cloth or optical cleaning tissue
2. Soft bristled brush
3. Isopropyl Alcohol

##### Method

1. Brush loose debris from optical surfaces with brush or cloth.
2. Moisten cloth with isopropyl alcohol.
3. Gently wipe optical surface in a circular motion. Change tissue if any debris is visible.

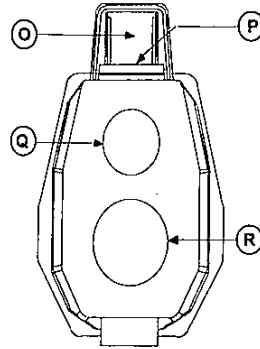

O. HUD COMBINER GLASS  
P. HUD SEALING WINDOW  
Q. TRANSMITTER OPTICS  
R. RECEIVER OPTICS

## APPENDIX C

### TECHNICAL SPECIFICATIONS

Dimensions	25.4 cm x 8.4 cm x 28 cm
Weight	2.09 kg including battery
Laser	Classification: Class I (21 CFR 1040.10&1040.11) Wavelength: 904 nm Beam Divergence: < 3 mrad x < 3 mrad Acquisition Time: 0.3 seconds
Speed	Range Max: 9144 m
Measurement	Accuracy: ± 1 km/h Acquisition: 0.3 sec Limits Approaching: +16 to +322 km/h Limits Receding: -16 to -322 km/h
Distance Range:	2 - 9 144m
Measurement Accuracy:	± 31 cm
Data I/O Type:	RS-232 Serial Data
Internal Recording:	PCMCIA Type II SRAM
Power/ Batteries	Nom. Voltage Range: 5.7 to 6.7 VDC Battery Type: NiMH Firing Current: < 400 mA (backlight off) Standby Current: < 200 mA (backlight off) Low Voltage Alert: 5.7 VDC
Charger/ 12 V Adapter	Voltage Range: 10.8 to 13.6 VDC
Displays	Rear Panel: 4 line x 20 char. LCD Head Up Display: 1 line x 4 char. LED and aiming crosshair
Temperature	Storage: -30° C to 60° C Operating: -40° C to 80° C (90% R.H. non-condensing)
Enclosure:	Water Resistant

## Appendix D

### SpeedLaser & Accessories

Standard Package

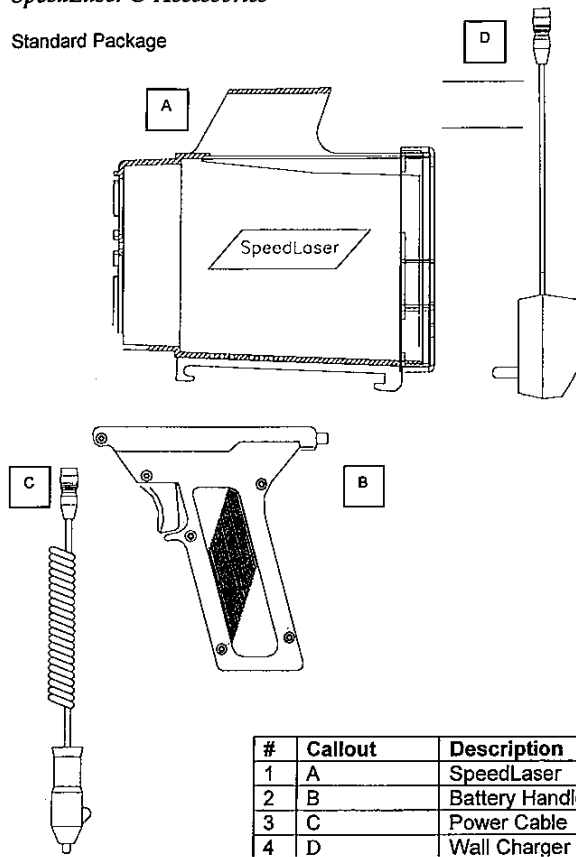

#	Callout	Description
1	A	SpeedLaser
2	B	Battery Handles
3	C	Power Cable
4	D	Wall Charger

## Appendix E

### Measuring Surface Datum

The measuring surface datum is located 10.8 centimeters back from the face of the gun. (This location corresponds to the vertical center of gravity of the unit.)

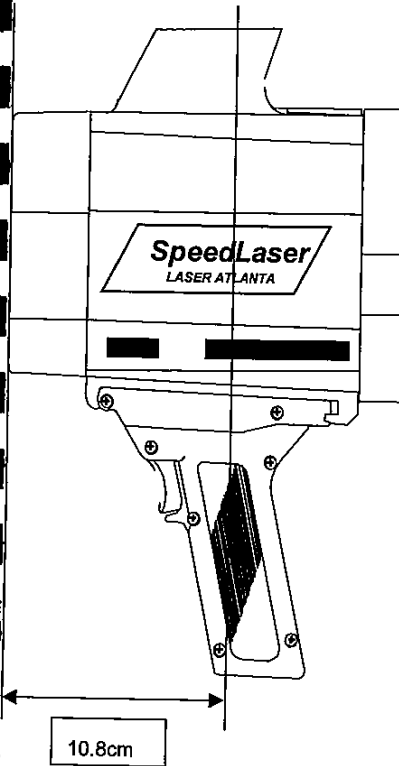

## **Appendix F**

### ***Battery Handles Notes***

The battery voltage reading is accessed from the SELF-TEST function of the unit. See page 20 for more information.

#### **Voltage Reading When Fully Charged**

Immediately after charging the NiMH battery handle, the voltage may temporarily read 7.0 volts or higher. It will quickly taper down to about 6.5 volts. This is a normal characteristic of NiMH battery cells.

#### **Voltage Reading While Operating**

Nominal battery voltage is 6.0 to 6.5 volts. This voltage range will appear while you are using an adequately charged handle.

#### **Voltage Reading When Battery is Near Empty**

After approximately 4 to 5 hours of typical use, the battery voltage will start to drop below 6.0 volts. When the voltage reaches 5.8 volts, the unit will emit a warning buzzer tone and the unit will no longer operate. At this point the handle must either be recharged, or you may switch to a 12V supply or another handle.

#### **Operating With a Discharged Handle and a 12V Source**

The unit can be operated from a 'dead battery' (discharged handle) with the use of the 12V wall power adapter or 12V cigarette adapter. To do this you should follow the procedure below:

- 1) Charge the handle for 5 or more minutes from the 12 V source.
- 2) Leave the 12V source attached to the handle and attach the handle to the SpeedLaser unit (if not already attached.)
- 3) Turn the unit on.
- 4) Note the voltage displayed (by the self-test function.)
- 5) If the display reads 6.0 volts or higher, begin using the unit. If it display <6.0 volts, repeat step 1).

The unit should now operate normally as long as the 12V supply is hooked up.

### Limited Warranty

Laser Atlanta warrants all SpeedLaser® products to be free from defects in materials and workmanship for a period of one (1) year from date of purchase. This warranty specifically excludes accessories, batteries and software. During this warranty period Laser Atlanta will replace defective materials and correct faulty workmanship at no charge, provided the product is returned to Laser Atlanta within the warranty period. If Laser Atlanta is unable to replace defective materials or correct faulty workmanship, Laser Atlanta will replace the product at no charge. These are your sole remedies for any breach of warranty.

### Return Policy

It is Laser Atlanta's policy and objective to allow prospective purchaser's ample opportunity to become familiar with our products prior to purchase. We do so through our product rental and demonstration programs. Customer satisfaction is very important to Laser Atlanta and we make every attempt to please customers whenever possible.

We are committed to designing and manufacturing products to the highest standards of quality and reliability. We offer an extended warranty that covers all materials and workmanship. In spite of our best efforts we do not want customers to incur unreasonable inconvenience due to equipment failure. Laser Atlanta will replace any product, or make a full refund, if repairs cannot be made to the satisfaction of the customer within the initial sixty days of ownership. After the initial sixty days of ownership Laser Atlanta will honor its warranty through either the repair or replacement of any malfunctioning products.

# LASER ATLANTA

LASER ATLANTA

2927 PETERSON PLACE  
NORCROSS, GA 30071

TEL 770-446-3866  
FAX 770-840-0462

MAIL TO: SALES@LASERATLANTA.COM

HTTP://WWW.LASERATLANTA.COM

